

Design No. **V488**

February 13, 2023

Nonbearing Wall Rating — 1 or 2 Hr. (See Items 5 and 5A)

*** Indicates such products shall bear the UL or cUL Certification Mark for jurisdictions employing the UL or cUL Certification (such as Canada), respectively.**

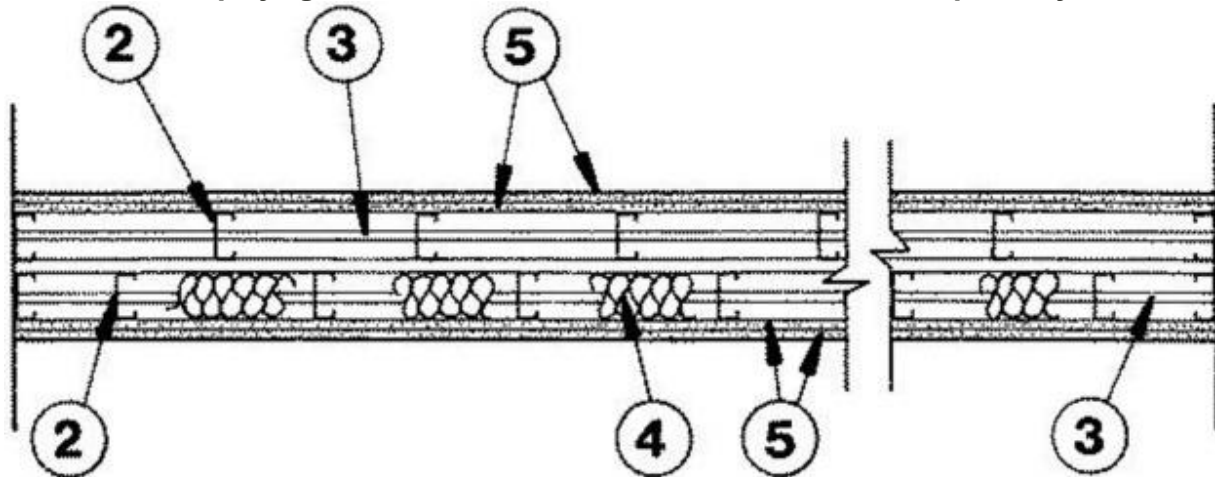

HORIZONTAL SECTION

1. **Floor and Ceiling Runners** — (For use with Item 5) — Channel shaped, attached to floor and ceiling in two rows, a min 1 in. apart, with steel fasteners spaced 24 in. OC. Runners fabricated from min No. 25 MSG galv steel, 1-1/4 in. wide and min 2-1/2 in. deep.

1A. **Floor and Ceiling Runners** — (As an alternate to Item 1, For use with Item 5A, 5B, and 5C) — Channel shaped, attached to floor and ceiling in two rows, a min 1 in. apart. Runners fabricated from min No. 20 MSG galv steel, 1-3/16 in. wide and min 2-9/16 in. deep.

1B. **Framing Members*** — **Floor and Ceiling Runners** — (Not Shown) — As an alternate to Item 1 - For use with Item 2B, channel shaped, min 2-1/2 in. deep fabricated from min 0.018 in. thick galv steel, attached to floor and ceiling with fasteners 24 in. OC. max.

CLARKDIETRICH BUILDING SYSTEMS — CD ProTRAK

DMFCWBS L L C — ProTRAK

MBA METAL FRAMING — ProTRAK

RAM SALES L L C — Ram ProTRAK

STEEL STRUCTURAL PRODUCTS L L C — Tri-S ProTRAK

1C. Framing Members* — Floor and Ceiling Runners — (Not Shown) — As an alternate to Item 1 - For use with Item 2C, channel shaped, min 2-1/2 in. deep fabricated from min 0.018 in. thick galv steel, attached to floor and ceiling with fasteners 24 in. OC. max.

TELLING INDUSTRIES L L C — TRUE-TRACK™

1D. Framing Members* — Floor and Ceiling Runners — (Not Shown) — As an alternate to Item 1 - For use with Item 2D, channel shaped, min 2-1/2 in. deep, attached to floor and ceiling with fasteners 24 in. OC. max.

MARINO/WARE, DIV OF WARE INDUSTRIES INC — Viper20™ Track

IMPERIAL MANUFACTURING GROUP INC — Viper20™ Track

1E. Framing Members* — Floor and Ceiling Runners — (Not Shown) — As an alternate to Item 1 for a 2 hour rating only - For use with Item 2E, channel shaped, min 2-1/2 in. deep, attached to floor and ceiling with fasteners 24 in. OC. max.

MARINO/WARE, DIV OF WARE INDUSTRIES INC — Viper25™ Track

IMPERIAL MANUFACTURING GROUP INC — Viper25™ Track

1F. Framing Members* — Floor and Ceiling Runners — (Not Shown) — As an alternate to Item 1 - For use with Item 2F, channel shaped, min 3-1/2 in. deep fabricated from min 0.018 in. thick galv steel, attached to floor and ceiling with fasteners 24 in. OC. max.

RESCUE METAL FRAMING, L L C — AlphaTRAK

2. Steel Studs — (For use with Item 5) — Channel shaped, supplied with cutouts, friction -fitted into floor and ceiling runners and spaced a max 24 in. OC. Studs cut 1/2 in. less than assembly height and evenly staggered between the two rows of floor and ceiling runners. Studs fabricated from min No. 25 MSG galv steel, min 2-1/2 in. deep by 1-5/8 in. wide with 3/8 in. folded back return flange legs.

2A. Steel Studs — (As an alternate to Item 2, For use with Items 5A, 5B, and 5C) — Channel shaped, supplied with cutouts, friction -fitted into floor and ceiling runners and spaced a max 16 in. OC. Studs cut 1/2 in. less than assembly height and staggered flush against the floor runners. Studs fabricated from min No. 20 MSG galv steel, min 2-1/2 in. deep by 1-3/16 in. wide with 1/4 in. folded back return flange legs.

2B. Framing Members* — Steel Studs — As an alternate to Item 2 — For use with Item 1B, channel shaped studs, min 2-1/2 in. deep fabricated from min 0.018 in. thick galv steel, spaced a max of 24 in. OC. Studs to be cut 1/2 in. less than assembly height.

CLARKDIETRICH BUILDING SYSTEMS — CD ProSTUD

DMFCWBS L L C — ProSTUD

MBA METAL FRAMING — ProSTUD

RAM SALES L L C — Ram ProSTUD

STEEL STRUCTURAL PRODUCTS L L C — Tri-S ProSTUD

2C. **Framing Members* — Steel Studs** — As an alternate to Item 2 — For use with Item 1C, channel shaped studs, min 2-1/2 in. deep fabricated from min 0.018 in. thick galv steel, spaced a max of 24 in. OC. Studs to be cut 1/2 in. less than assembly height.

TELLING INDUSTRIES L L C — TRUE-STUD™

2D. **Framing Members* — Steel Studs** — As an alternate to Item 2 — For use with Item 1D, channel shaped studs, min 2-1/2 in. deep, spaced a max of 24 in. OC. Studs to be cut 3/4 in. less than assembly height.

MARINO/WARE, DIV OF WARE INDUSTRIES INC — Viper20™

IMPERIAL MANUFACTURING GROUP INC — Viper20™

2E. **Framing Members* — Steel Studs** — As an alternate to Item 2 for a 2 hour rating only — For use with Item 1E, channel shaped studs, min 2-1/2 in. deep, spaced a max of 24 in. OC. Studs to be cut 3/4 in. less than assembly height.

MARINO/WARE, DIV OF WARE INDUSTRIES INC — Viper25™

IMPERIAL MANUFACTURING GROUP INC — Viper25™

2F. **Framing Members* — Steel Studs** — As an alternate to Item 2 — For use with Item 1F, channel shaped studs, min 2-1/2 in. deep fabricated from min 0.018 in. thick galv steel, spaced a max of 24 in. OC. Studs to be cut 1/2 in. less than assembly height.

RESCUE METAL FRAMING, L L C — AlphaSTUD

3. **Lateral Bracing** — The bracing shall be in accordance with the SSMA Technical Note Dated March 2000 Referencing Unsheathed Flange Bracing.

3A. **Framing Members* — Lateral Bracing** — (Not Shown) — Right angle- shaped, supplied with notches spaced 12, 16, or 24 in. OC., friction-fitted to the cutouts in steel studs, supplied in 7/8 in. by 7/8 in. by 50 in. lengths. Lateral bracing bars fabricated from min. 20 MSG galvanized steel. The bracing shall be located a maximum of 5 ft on center in accordance with the manufacturers published literature.

CLARKDIETRICH BUILDING SYSTEMS — TradeReady Spazzer 9200 bar

4. **Batts and Blankets*** — Optional — Glass fiber batts may be friction-fitted to completely fill the stud cavities on one or both rows of studs.

See **Batts and Blankets** (BZJZ) Category for names of manufacturers.

5. **Gypsum Board*** — Nom 5/8 in. thick, 4 ft. wide, gypsum panels with beveled, square or tapered edges.. **For single layer systems** gypsum panels applied vertically or horizontally with joints centered over studs. Horizontal edge joints and horizontal butt joints on opposite sides of studs need not be staggered or backed by steel framing. Gypsum panels fastened to framing with 1 in. long Type S steel screws 12 in. OC along vertical edges and in the field. and 12 in. along the top and bottom of the wall. When studs (Item 2) spaced a max 16 in. OC, 5/8 in. thick gypsum panels applied vertically or horizontally, 1 in. long Type S screws spaced 16 in. OC along vertical edges and in the field, and 16 in. OC along top and bottom of wall. **For two layer systems** gypsum panels applied vertically or horizontally. Vertical joints centered over studs and staggered one stud cavity on opposite sides of studs and in adjacent layers. Horizontal joints need not be backed by steel framing. Horizontal edge joints and horizontal butt joints on opposite sides of studs need not be staggered. Horizontal edge joints in adjacent layers staggered a min of 12 in. First layer secured with 1 in. long

Type S or S-12 steel screws, spaced 16 in. OC. Second layer secured with 1-5/8 in. long Type S or S-12 steel screws, spaced 16 in. OC with screws offset 8 in. from first layer. Screw spacings remain the same when applied to furring channels.

NATIONAL GYPSUM CO — Types eXP-C, FSK, FSK-C, FSK-G, FSW-C, FSW-G, FSW, FSW-3, FSW-5, FSW-6, FSMR-C

5A. **Gypsum Board*** — (As an alternate to Item 5 may be used as the base layer on one or both sides of wall. For direct attachment only) — Nom 5/8 in. thick lead backed gypsum panels with beveled, square or tapered edges, applied vertically. Vertical joints centered over studs and staggered min 1 stud cavity on opposite sides of studs. Gypsum board secured to studs with 1-1/4 in. long Type S-12 steel screws spaced 8 in. OC at perimeter and 12 in. OC in the field.

RAY-BAR ENGINEERING CORP — Type RB-LBG

5B. **Gypsum Board*** — (As an alternate to Item 5 may be used as the base layer on one or both sides of wall. For direct attachment only) — Nom 5/8 in. thick lead backed gypsum panels with beveled, square or tapered edges, applied vertically. Vertical joints centered over studs and staggered min 1 stud cavity on opposite sides of studs. Wallboard secured to studs with 1-1/4 in. long Type S-12 steel screws gypsum panel steel screws spaced 8 in. OC at perimeter and 12 in. OC in the field. Lead batten strips required behind vertical joints of lead backed gypsum wallboard and optional at remaining stud locations. Lead batten strips, min 2 in. wide, max 8 ft long with a max thickness of 0.14 in. placed on the face of studs and attached to the stud with construction adhesive and two 1 in. long Type S-12 pan head steel screws, one at the top of the strip and one at the bottom of the strip. Lead discs, nominal 3/8 in. diam by max 0.085 in. thick. Compression fitted or adhered over the screw heads. Lead batten strips and discs to have a purity of 99.9% meeting the Federal specification QQ-L-201f, Grade "C".

RADIATION PROTECTION PRODUCTS INC — Type RPP-LBG

5C. **Gypsum Board*** — (As an alternate to Item 5 when used as the base layer on one or both sides of wall, For direct attachment only) — Nom 5/8 in. thick lead backed gypsum panels with beveled, square or tapered edges, applied vertically. Vertical joints centered over studs and staggered min 1 stud cavity on opposite sides of studs. Wallboard secured to studs with 1-1/4 in. long Type S-12 steel screws spaced 8 in. OC at perimeter and in the field when applied as the base layer. Lead batten strips required behind vertical joints of lead backed gypsum wallboard and optional at remaining stud locations. Lead batten strips, min 2 in. wide, max 10 ft long with a max thickness of 0.140 in. placed on the face of studs and attached to the stud with two 1 in. long Type S-8 pan head steel screws, one at the top of the strip and one at the bottom of the strip. Lead discs, max 5/16 in. diam by max 0.140 in. thick compression fitted or adhered over the screw heads. Lead batten strips and discs to have a purity of 99.9% meeting the Federal specification QQ-L-201f, Grades "A, B, C or D". Fasteners for face layer gypsum panels (Items 5) when installed over lead backed board to be min 2-1/2 in. Type S-12 bugle head steel screws spaced as described in Item 6.

MAYCO INDUSTRIES INC — "X-Ray Shielded Gypsum"

5D. **Gypsum Board*** — (As an alternate to 5/8 in. Type FSW in Item 5) — Nom. 5/16 in. thick gypsum panels applied vertically or horizontally. Two layers of 5/16 in. for every single layer of 5/8 in. gypsum board described in Item 5. Horizontal joints on the same side need not be staggered. Inner layer of each double 5/16 in. layer attached with fasteners, as described in item 5, spaced 24 in. OC. Outer layer of each double 5/16 in. layer attached per Item 5.

NATIONAL GYPSUM CO — Type FSW

5E. **Gypsum Board*** — (As an alternate to Items 5 through 5D) — Nominal 5/8 in. thick, 4 ft wide panels, applied vertically only fastened to the studs and plates with 1 in. long, Type S steel screws spaced, 12 in. OC.

NATIONAL GYPSUM CO — Type SBWB

6. **Joint Tape and Compound** — (Not Shown) — Outer layer joints covered with joint compound and paper or mesh tape. Screw heads covered with joint compound. Paper or mesh tape and joint compound may be omitted when gypsum boards are supplied with square edges.

7. **Lead Batten Strips** — (Not Shown, For Use With Item 5A) — Used in lieu of or in addition to the lead batten strips (Item 8) or optional at other locations - Max 3/4 in. diam by max 0.125 in. thick lead discs compression fitted or adhered over steel screw heads or max 1/2 in. by 1-1/4 in. by max 0.125 in. thick lead tabs placed on gypsum boards (Item 5C) underneath screw locations prior to the installation of the screws. Lead discs or tabs to have a purity of 99.9% meeting the Federal specification QQ-L-201f, Grade "C".

8. **Lead Discs or Tabs** — (Not Shown, For Use With Item 5A) — Used in lieu of or in addition to the lead batten strips (Item 8) or optional at other locations - Max 3/4 in. diam by max 0.125 in. thick lead discs compression fitted or adhered over steel screw heads or max 1/2 in. by 1-1/4 in. by max 0.125 in. thick lead tabs placed on gypsum boards (Item 5C) underneath screw locations prior to the installation of the screws. Lead discs or tabs to have a purity of 99.9% meeting the Federal specification QQ-L-201f, Grade "C".

9. **Wall and Partition Facings and Accessories*** — (Optional, Not Shown) — For use with Item 5- Nominal 1/2 in. thick, 4 ft wide panels, for optional use as an additional layer on one or both sides of the assembly. Panels attached in accordance with manufacturer's recommendations. When the SoundBreak gypsum board is installed between the steel framing and the UL Classified gypsum board, the required UL Classified gypsum board layer(s) is/are to be installed as indicated as to fastener type and spacing, except that the required fastener length shall be increased by a minimum of 1/2 in. Not evaluated or intended as a substitute for the required layer(s) of UL Classified Gypsum Board.

NATIONAL GYPSUM CO — SoundBreak Gypsum Board.

10. **Framing Members*** — (Optional on one or both sides, not shown, for single or double layer systems, not for use with items 5A, 5B or 5C) — Furring channels and Steel Framing Members as described below:

a. **Furring Channels** — Formed of No. 25 MSG galv steel. 2-9/16 in. or 2-23/32 in. wide by 7/8 in. deep, spaced max. 24 in. OC perpendicular to studs. Channels secured to studs as described in Item b.

b. **Steel Framing Members*** — Used to attach furring channels (Item 10a) to studs. Clips spaced max. 48 in. OC. RSIC-1 and RSIC-1 (2.75) clips secured to studs with No. 8 x 1-1/2 in. minimum self-drilling, S-12 steel screw through the center grommet. RSIC-V and RSIC-V (2.75) clips secured to studs with No. 8 x 9/16 in. minimum self-drilling, S-12 steel screw through the center hole. Furring channels are friction fitted into clips. RSIC-1 and RSIC-V clips for use with 2-9/16 in. wide furring channels. RSIC-1 (2.75) and RSIC-V (2.75) clips for use with 2-23/32 in. wide furring channels.

PAC INTERNATIONAL L L C — Types RSIC-1, RSIC-V, RSIC-1 (2.75), RSIC-V (2.75).

10A. **Framing Members*** — (Optional on one or both sides, not shown, for single or double layer systems, not for use with items 5A, 5B or 5C) — Furring channels and Steel Framing Members as described below:

a. **Furring Channels** — Formed of No. 25 MSG galv steel, 2-5/8 in. wide by 7/8 in deep, spaced 24 in. OC perpendicular to studs. Channels secured to studs as described in Item b. Ends of adjoining channels overlapped 6 in. and tied together with double strand of No. 18 AWG galvanized steel wire. Gypsum board attached to furring channels as described in Item 5.

b. **Steel Framing Members*** — Used to attach furring channels (Item a) to studs. Clips spaced 48 in. OC., and secured to studs with 2 in. coarse drywall screw with 1 in. diam washer through the center hole. Furring channels are friction fitted into clips.

STUDCO BUILDING SYSTEMS — RESILMOUNT Sound Isolation Clips - Type A237R

10B. **Steel Framing Members*** — (Not Shown) — (Optional on one or both sides, not shown, for single or double layer systems, not for use with items 5A, 5B, or 5C) — Furring channels and Steel Framing Members as described below:

a. **Furring Channels** — Formed of No. 25 MSG galv steel, spaced 24 in. OC, and perpendicular to studs. Channels secured to studs as described in Item b. Ends of adjoining channels overlapped 6 in. and secured in place with a double strand of No. 18 AWG twisted steel wire. Gypsum board attached to furring channels as described in Item 5.

b. **Steel Framing Members*** — Used to attach furring channels (Item 10Ba) to studs. Clips spaced 48 in. OC., and secured to studs with No. 8 x 2-1/2 in. coarse drywall screw through the center hole. Furring channels are friction fitted into clips.

REGUPOL AMERICA — Type SonusClip

10C. **Steel Framing Members*** — (Optional on one or both sides, not shown, for single or double layer systems, not for use with items 5A, 5B, or 5C) — Resilient channels and Steel Framing Members as described below:

a. **Resilient Channels** — Formed of No. 25 MSG galv steel, spaced 24 in. OC, and perpendicular to studs. Channels secured to studs as described in Item b. Ends of adjoining channels overlapped 6 in. and secured in place with two No. 8 15 x 1/2 in. Philips Modified Truss screws spaced 2-1/2 in. from the center of the overlap. Gypsum board attached to resilient channels as described in Item 5.

b. **Steel Framing Members*** — Used to attach resilient channels (Item 10Ca) to studs. Clips spaced 48 in. OC., and secured to studs with No. 8 x 2-1/2 in. coarse drywall screw through the center hole. Resilient channels are secured to clips with one No. 10 x 1/2 in. pan-head self-drilling screw.

KEENE BUILDING PRODUCTS CO INC — Type RC+ Assurance Clip

*** Indicates such products shall bear the UL or cUL Certification Mark for jurisdictions employing the UL or cUL Certification (such as Canada), respectively.**

Last Updated on 2023-02-13