

Design No. U411

October 13, 2020

Nonbearing Wall Rating — 2 Hr.

* Indicates such products shall bear the UL or cUL Certification Mark for jurisdictions employing the UL or cUL Certification (such as Canada), respectively.

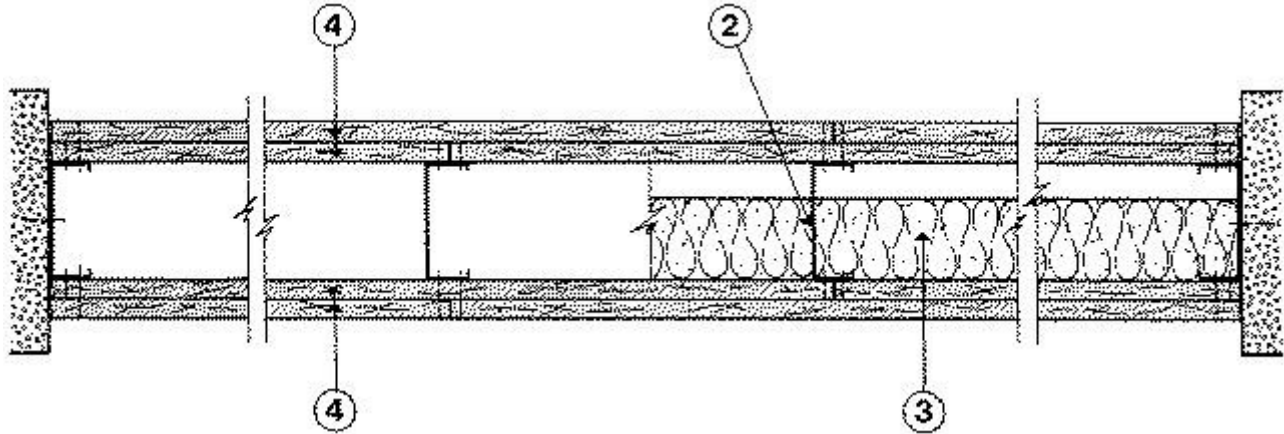

1. **Floor and Ceiling Runner** — (Not Shown) — Min. 25 MSG galv steel, 1 in. return legs, 2-1/2 in. deep (min), attached to floor and ceiling with fasteners 24 in. OC max.

1A. **Framing Members*** — **Floor and Ceiling Runners** — (Not Shown) — As an alternate to Item 1 - For use with Item 2A, channel shaped, min 2-1/2 in. deep, attached to floor and ceiling with fasteners 24 in. OC. max.

ALLSTEEL & GYPSUM PRODUCTS INC — Type SUPREME D24/30EQD and Type SUPREME D20

CALIFORNIA EXPANDED METAL PRODUCTS CO — Viper20™ Track

CONSOLIDATED FABRICATORS CORP, BUILDING PRODUCTS DIV — Type SUPREME D24/30EQD and Type SUPREME D20

MARINO/WARE, DIV OF WARE INDUSTRIES INC — Viper20™ Track

FUSION BUILDING PRODUCTS — Viper20™ Track

IMPERIAL MANUFACTURING GROUP INC — Viper20™ Track

QUAIL RUN BUILDING MATERIALS INC — Type SUPREME D24/30EQD and Type SUPREME D20

SCAFCO STEEL STUD MANUFACTURING CO — Type SUPREME D24/30EQD and Type SUPREME D20

STEEL CONSTRUCTION SYSTEMS INC — Type SUPREME D24/30EQD and Type SUPREME D20

UNITED METAL PRODUCTS INC — Type SUPREME D24/30EQD and Type SUPREME D20

1B. Floor and Ceiling Runners — (Not Shown) — For use with Item 2B- Channel shaped, fabricated from min 20 MSG corrosion-protected or galv steel, min width to accommodate stud size, with min 1 in. long legs, attached to floor and ceiling with fasteners spaced max 24 in. OC.

1C. Framing Members* — Floor and Ceiling Runners — (Not Shown) — As an alternate to Item 1 - For use with Item 2C, channel shaped, min 2-1/2 in. wide fabricated from min 0.015 in. thick galv steel, attached to floor and ceiling with fasteners 24 in. OC. max.

CLARKDIETRICH BUILDING SYSTEMS — CD ProTRAK

DMFCWBS L L C — ProTRAK

MBA METAL FRAMING — ProTRAK

RAM SALES L L C — Ram ProTRAK

STEEL STRUCTURAL PRODUCTS L L C — Tri-S ProTRAK

1D. Framing Members* — Floor and Ceiling Runners — (Not Shown) — As an alternate to Item 1 - For use with Item 2D, channel shaped, min 2-1/2 in. wide fabricated from min 0.018 in. thick galv steel, attached to floor and ceiling with fasteners 24 in. OC. max.

TELLING INDUSTRIES L L C — TRUE-TRACK™

1E. Framing Members* — Floor and Ceiling Runners — (Not Shown) — As an alternate to Item 1 - For use with Item 2E, channel shaped, min 2-1/2 in. wide fabricated from min 25 MSG steel, attached to floor and ceiling with fasteners 24 in. OC. max.

KIRII (HONG KONG) LTD — Type KIRII

1F. Floor and Ceiling Runners — (Not Shown) — Channel shaped, min width to accommodate stud size, with min 1 in. long legs, for use with studs specified below, attached to floor and ceiling with fasteners spaced max 24 in. OC.

MARINO/WARE, DIV OF WARE INDUSTRIES INC — Viper20™ Track VT100

FUSION BUILDING PRODUCTS — Viper20™ Track

IMPERIAL MANUFACTURING GROUP INC — Viper20™ Track

1G. Framing Members* — Floor and Ceiling Runners — (Not Shown) — As an alternate to Item 1 - For use with Item 2G, channel shaped, min 2-1/2 in. deep, attached to floor and ceiling with fasteners 24 in. OC. max.

TELLING INDUSTRIES L L C — Viper20™ Track

1H. Framing Members* — Floor and Ceiling Runners — (Not Shown) — As an alternate to Item 1 - For use with Item 2J. Channel shaped, attached to floor and ceiling with fasteners 24 in. OC. max.

BAILEY METAL PRODUCTS LTD — Type PLATINUM PLUS

1I. Framing Members* — Floor and Ceiling Runners — (Not Shown) — As an alternate to Item 1 - For use with Item 2K, channel shaped, min 3-1/2 in. wide fabricated from min 0.018 in. thick galv steel, attached to floor and ceiling with fasteners 24 in. OC. max.

RESCUE METAL FRAMING, L L C — AlphaTRAK

1J. Framing Members* — Floor and Ceiling Runners — (Not Shown) — As an alternate to Item 1 - For use with Item 2L. Channel shaped, attached to floor and ceiling with fasteners 24 in. OC. max.

OEG BUILDING MATERIALS — OEG Track

1K. Framing Members* — Floor and Ceiling Runners — (Not Shown) — As an alternate to Item 1 - For use with Item 2M, channel shaped, min 2-1/2 in. deep, formed of min. 25 MSG (0.018 in. min. bare metal thickness), attached to floor and ceiling with fasteners 24 in. OC. max.

CALIFORNIA EXPANDED METAL PRODUCTS CO — Viper X Track

1L. Framing Members* — Floor and Ceiling Runners — (Not Shown) — As an alternate to Item 1 - For use with Item 2N. Channel shaped, min. 2-1/2 in. deep, attached to floor and ceiling with fasteners 24 in. OC. max.

ALLSTEEL & GYPSUM PRODUCTS INC — Type SUPREME D25

CONSOLIDATED FABRICATORS CORP, BUILDING PRODUCTS DIV — Type SUPREME D25

QUAIL RUN BUILDING MATERIALS INC — Type SUPREME D25

SCAFCO STEEL STUD MANUFACTURING CO — Type SUPREME D25

STEEL CONSTRUCTION SYSTEMS INC — Type SUPREME D25

UNITED METAL PRODUCTS INC — Type SUPREME D25

1M. **Floor and Ceiling Runner** — (Not shown) - As an alternate to Item 1, For use with Items 2O and 4O - Min 25 MSG galv steel, 1-5/8 in. deep (min), attached to floor and ceiling with fasteners 24 in. OC. max.

2. **Steel Studs** — Min 2-1/2 in. deep, formed of min 25 MSG galv steel max stud spacing 24 in. OC. Studs to be cut 3/4 in. less than assembly height.

2A. **Framing Members*** — **Steel Studs** — As an alternate to Item 2 — For use with Item 1G, channel shaped studs, min 2-1/2 in. deep, spaced a max of 24 in. OC. Studs to be cut 3/4 in. less than assembly height.

ALLSTEEL & GYPSUM PRODUCTS INC — Type SUPREME D24/30EQD and Type SUPREME D20

CALIFORNIA EXPANDED METAL PRODUCTS CO — Viper20™

CONSOLIDATED FABRICATORS CORP, BUILDING PRODUCTS DIV — Type SUPREME D24/30EQD and Type SUPREME D20

MARINO/WARE, DIV OF WARE INDUSTRIES INC — Viper20™

FUSION BUILDING PRODUCTS — Viper20™

IMPERIAL MANUFACTURING GROUP INC — Viper20™

QUAIL RUN BUILDING MATERIALS INC — Type SUPREME D24/30EQD and Type SUPREME D20

SCAFCO STEEL STUD MANUFACTURING CO — Type SUPREME D24/30EQD and Type SUPREME D20

STEEL CONSTRUCTION SYSTEMS INC — Type SUPREME D24/30EQD and Type SUPREME D20

UNITED METAL PRODUCTS INC — Type SUPREME D24/30EQD and Type SUPREME D20

2B. **Steel Studs** — (As an alternate to Item 2, For use with Item 4D, 4H, and 4J) — Channel shaped, fabricated from min 20 MSG corrosion-protected or galv steel, 3-1/2 in. min depth, spaced a max of 16 in. OC. Studs friction-fit into floor and ceiling runners. Studs to be cut 5/8 to 3/4 in. less than assembly height.

2C. **Framing Members* — Steel Studs** — As an alternate to Item 2 — For use with Item 1C, channel shaped studs, min 2-1/2 in. wide fabricated from min 0.015 in. thick galv steel, spaced a max of 24 in. OC. Studs to be cut 3/4 in. less than assembly height.

CLARKDIETRICH BUILDING SYSTEMS — CD ProSTUD

DMFCWBS L L C — ProSTUD

MBA METAL FRAMING — ProSTUD

RAM SALES L L C — Ram ProSTUD

STEEL STRUCTURAL PRODUCTS L L C — Tri-S ProSTUD

2D. **Framing Members* — Steel Studs** — As an alternate to Item 2 — For use with Item 1D, channel shaped studs, min 2-1/2 in. wide fabricated from min 0.018 in. thick galv steel, spaced a max of 24 in. OC. Studs to be cut 3/4 in. less than assembly height.

TELLING INDUSTRIES L L C — TRUE-STUD™

2E. **Framing Members* — Steel Studs** — As an alternate to Item 2 — For use with Item 1E, channel shaped studs, min 2-1/2 in. wide fabricated from min 25 MSG steel, spaced a max of 24 in. OC. Studs to be cut 3/4 in. less than assembly height.

KIRII (HONG KONG) LTD — Type KIRII

2F. **Framing Members* — Steel Studs** — As an alternate to Item 2 — For use with Item 1G, channel shaped studs, min 2-1/2 in. deep, spaced a max of 24 in. OC. Studs to be cut 3/4 in. less than assembly height.

TELLING INDUSTRIES L L C — Viper20™

2G. **Framing Members* — Steel Studs** — As an alternate to Item 2 — For use with Item 1, channel shaped studs, Min 2-1/2 in. deep, formed of min 25 MSG galv steel max stud spacing 24 in. OC. Studs to be cut 3/4 in. less than assembly height.

EB METAL INC — NITROSTUD

2H. **Framing Members* — Steel Studs** — As an alternate to Item 2 — For use with Item 1, channel shaped studs, Min 2-1/2 in. deep, formed of min 25 MSG galv steel max stud spacing 24 in. OC. Studs to be cut 3/4 in. less than assembly height.

OLMAR SUPPLY INC — PRIMESTUD

2I. **Framing Members* — Steel Studs** — As an alternate to Item 2 — For use with Item 1A (3-5/8 in. wide track), channel shaped studs, fabricated from min 25 MSG corrosion-protected steel, 1-1/4 in. wide by 3-5/8 in. deep, spaced a max of 24 in. OC. Studs to be cut 3/8 to 3/4 in. less than assembly height.

MARINO/WARE, DIV OF WARE INDUSTRIES INC — StudRite™

2J. **Framing Members* — Steel Studs** — As an alternate to Item 2 — For use with Item 1H, channel shaped, min 3-5/8 in. wide, spaced a max of 24 in. OC. Studs to be cut 3/8 to 3/4 in. less than assembly height.

BAILEY METAL PRODUCTS LTD — Type PLATINUM PLUS

2K. **Framing Members* — Steel Studs** — As an alternate to Item 2 — For use with Item 1I, channel shaped studs, min 3-1/2 in. wide fabricated from min 0.018 in. thick galv steel, spaced a max of 24 in. OC. Studs to be cut 3/4 in. less than assembly height.

RESCUE METAL FRAMING, L L C — AlphaSTUD

2L. **Framing Members* — Steel Studs** — As an alternate to Item 2 — For use with Item 1J, channel shaped studs, Min 2-1/2 in. deep, formed of min 25 MSG galv steel max stud spacing 24 in. OC. Studs to be cut 3/8 to 3/4 in. less than assembly height.

OEG BUILDING MATERIALS — OEG Stud

2M. **Framing Members* — Steel Studs** — As an alternate to Item 2 — For use with Item 1K, channel shaped studs, min 2-1/2 in. deep, formed of min. 25 MSG (0.018 in. min. bare metal thickness), spaced a max of 24 in. OC. Studs to be cut 3/4 in. less than assembly height.

CALIFORNIA EXPANDED METAL PRODUCTS CO — Viper X

2N. **Framing Members* — Steel Studs** — As an alternate to Item 2 — For use with Item 1L, channel shaped studs, min depth 2-1/2 in. deep, spaced a max of 24 in. OC. Studs to be cut 3/4 in. less than assembly height.

ALLSTEEL & GYPSUM PRODUCTS INC — Type SUPREME D25

CONSOLIDATED FABRICATORS CORP, BUILDING PRODUCTS DIV — Type SUPREME D25

QUAIL RUN BUILDING MATERIALS INC — Type SUPREME D25

SCAFCO STEEL STUD MANUFACTURING CO — Type SUPREME D25

STEEL CONSTRUCTION SYSTEMS INC — Type SUPREME D25

UNITED METAL PRODUCTS INC — Type SUPREME D25

2O. Framing Members — Steel Studs — (As an alternate to Item 2) For use with Items 1M and 4O - channel shaped studs min 1-5/8 in. deep, formed of 25 MSG galv steel, max stud spacing 24 in. OC. Studs cut 3/8 in. to 3/4 in. less than assembly height.

3. Batts and Blankets* — (Optional) — Mineral wool or glass fiber batts partially or completely filling stud cavity. See **Batts and Blankets** (BZJZ) category for names of manufacturers

ROCKWOOL — Type AFB, min. density 1.69 pcf / 27.0 kg/m³

ROCKWOOL MALAYSIA SDN BHD — Type Acoustical Fire Batts

3A. Fiber, Sprayed* — As an alternate to Batts and Blankets (Item 3) — (100% Borate Formulation) — Spray applied cellulose material. The fiber is applied with water to completely fill the enclosed cavity in accordance with the application instructions supplied with the product with a nominal dry density of 2.7 lb/ft³. Alternate Application Method: The fiber is applied without water or adhesive at a nominal dry density of 3.5 lb/ft³, in accordance with the application instructions supplied with the product.

U S GREENFIBER L L C — INS735, INS745 and INS750LD for use with wet or dry application. INS765LD and INS773LD are to be used for dry application only.

3B. Fiber, Sprayed* — As an alternate to Batts and Blankets (Item 3) — Spray applied cellulose insulation material. The fiber is applied with water to interior surfaces in accordance with the application instructions supplied with the product. Applied to completely fill the enclosed cavity. Minimum dry density of 4.3 pounds per cubic ft.

NU-WOOL CO INC — Cellulose Insulation

3C. Fiber, Sprayed* — As an alternate to Batts and Blankets (Item 3) — Spray applied cellulose fiber. The fiber is applied with water to completely fill the enclosed cavity in accordance with the application instructions supplied with the product. The minimum dry density shall be 4.30 lbs/ft³.

INTERNATIONAL CELLULOSE CORP — Celbar-RL

3D. Fiber, Sprayed* — As an alternate to Batts and Blankets (Item 3) — Spray-applied cellulose material. The fiber is applied with water to completely fill the enclosed cavity in accordance with the application instructions supplied with

the product. To facilitate the installation of the material, any thin, woven or non-woven netting may be attached by any means possible to the outer face the studs. The material shall reach equilibrium moisture content before the installation of materials on either face of the studs. The minimum dry density shall be 5.79 lbs/ft³.

APLEGATE HOLDINGS L L C — Applegate Advanced Stabilized Cellulose Insulation

4. **Gypsum Board*** — 5/8 in. thick, outer layer paper, glass mat or vinyl surfaced. (Laminated System) Gypsum board applied vertically in two layers. Inner layer attached to studs with 1 in. long Type S steel screws spaced 8 in. OC along vertical edges, and 12 in. OC in the field and outer layer laminated to inner layer with joint compound, applied with a notched spreader producing continuous beads of compound about 3/8 in. in diameter, spaced not greater than 2 in. OC. Joints of laminated outer layer offset 12 in. from inner layer joints Outer layer gypsum board attached to floor and ceiling runner track with 1-5/8 in. long Type S steel screws spaced 12 in. OC.

Optional, (Direct Attached System), Inner layer attached to studs with 1 in. long Type S steel screws spaced 16 in. OC in the field and along the vertical edges. Outer layer attached to the studs over the inner layer with 1-5/8 in. long Type S steel screws spaced 16 in. OC in the field and along the vertical edges and 12 in. OC to the floor and ceiling runners. Joints of screw-attached outer layer offset from inner layer joints. Joints of outer layer may be taped or untaped.

Nom 3/32 in. thick gypsum veneer plaster may be applied to the entire surface of Classified veneer baseboard. Joints reinforced.

AMERICAN GYPSUM CO — Types AG-C, AGX-1, M-Glass, AGX-11, LightRoc

BEIJING NEW BUILDING MATERIALS PUBLIC LTD CO — Type DBX-1

CABOT MANUFACTURING ULC — Type X, 5/8 Type X, Type Blueglass Exterior Sheathing

CERTAINTED GYPSUM INC — Types EGRG, GlasRoc, GlasRoc-2, Type X, Type X-1, Type C, or 5/8" Easi-Lite Type X

CGC INC — Type AR, C, IP-AR, IP-X1, IP-X2, IPC-AR, SCX, SHX, ULIX, USGX, WRC or WRX

CONTINENTAL BUILDING PRODUCTS OPERATING CO, L L C — Types LGFC2A, LGFC6A, LGFC-C/A, LGFC-WD, LGLLX, CLLX

GEORGIA-PACIFIC GYPSUM L L C — Types 5, 6, 9, C, DAP, DD, DA, DAPC, DGG, DS, GPFS6, LS, TG-C, Type X, Veneer Plaster Base-Type X, Water Rated-Type X, Sheathing Type-X, Soffit-Type X, GreenGlass Type X, Type X ComfortGuard Sound Deadening Gypsum Board, Type LWX, Veneer Plaster Base-Type LWX, Water Rated-Type LWX, Sheathing Type-LWX, Soffit-Type LWX, Type DGLW, Water Rated-Type DGLW, Sheathing Type- DGLW, Soffit-Type DGLW, Type LW2X, Veneer Plaster Base - Type LW2X, Water Rated - Type LW2X, Sheathing - Type LW2X, Soffit - Type LW2X, Type DGL2W, Water Rated - Type DGL2W, Sheathing - Type DGL2W

NATIONAL GYPSUM CO — Types eXP-C, FSK, FSK-C, FSW, FSW-3, FSW-5, FSW-6, FSW-8, FSW-C, FSW-G, FSMR-C, FSL, Type SBWB, RSX.

NATIONAL GYPSUM CO — Riyadh, Saudi Arabia — Type FR, or WR.

PABCO BUILDING PRODUCTS L L C, DBA PABCO GYPSUM — Type C, PG-3, PG-5, PG-9, PG-11, PG-C, PGS-WRS, PGI

PANEL REY S A — Types GREX, GRIX, PRX, RHX, MDX, ETX, PRC, PRC2, PRX2

SIAM GYPSUM INDUSTRY (SARABURI) CO LTD — Type EX-1

SAINT-GOBAIN GYPROC MIDDLE EAST FZE — Type Gyproc FireStop, Gyproc FireStop MR, Gyproc FireStop M2TECH, Gyproc FireStop ACTIV'Air, Gyproc FireStop MR ACTIV'Air, Gyproc FireStop M2TECH ACTIV'Air, Gyproc DuraLine, Gyproc DuraLine MR, Gyproc DuraLine M2TECH, Gyproc DuraLine ACTIV'Air, Gyproc DuraLine MR ACTIV'Air, Gyproc DuraLine M2TECH ACTIV'Air

THAI GYPSUM PRODUCTS PCL — Type C or Type X

THE SIAM GYPSUM INDUSTRY (SONGKHLA) CO — Types C and SCX

UNITED STATES GYPSUM CO — Type AR, C, FRX-G, IP-AR, IP-X1, IP-X2, IPC-AR, SCX, SGX, SHX, ULIX, USGX, WRC, WRX

USG BORAL DRYWALL SFZ LLC — Types C, SCX, SGX, USGX

USG MEXICO S A DE C V — Type AR, C, IP-AR, IP-X1, IP-X2, IPC-AR, SCX, SHX, USGX, WRC or WRX

4A. **Gypsum Board*** — (As an alternate to Item 4) — Nom 3/4 in. thick, installed as described in Item 4 with 1-1/4 in. long Type S screws for inner layer and 2-1/4 in. long Type S screws for outer layer.

CGC INC — Types AR, IP-AR

UNITED STATES GYPSUM CO — Types AR, IP-AR

USG MEXICO S A DE C V — Types AR, IP-AR

4B. Gypsum Board* — (As an alternate to Items 4 and 4A) — 5/8 in. thick, 24 to 54 in. wide, applied horizontally as the outer layer to one side of the assembly. Horizontal joints need not be backed by steel framing. Secured as described in Item 4 for the direct attached system. When used in widths other than 48 in., gypsum panels to be installed horizontally.

CERTAINTED GYPSUM INC — Type X, Type C, Type GlasRoc

CGC INC — Type SHX

SAINT-GOBAIN GYPROC MIDDLE EAST FZE — Type Gyproc FireStop, Gyproc FireStop MR, Gyproc FireStop M2TECH, Gyproc FireStop ACTIV'Air, Gyproc FireStop MR ACTIV'Air, Gyproc FireStop M2TECH ACTIV'Air, Gyproc DuraLine, Gyproc DuraLine MR, Gyproc DuraLine M2TECH, Gyproc DuraLine ACTIV'Air, Gyproc DuraLine MR ACTIV'Air, Gyproc DuraLine M2TECH ACTIV'Air

THAI GYPSUM PRODUCTS PCL — Type X, Type C

UNITED STATES GYPSUM CO — Type SHX, FRX-G

USG MEXICO S A DE C V — Type SHX

4C. Gypsum Board* — (As an alternate to Items 4, 4A and 4B) — Two layers of 5/8 in. thick gypsum board applied horizontally or vertically. Inner layer attached to studs with No. 6 by 1 in. long Type S bugle head screws spaced 24 in. OC along the top and bottom tracks starting 2 in. and then 12 in. from the vertical edge. Inner layer screws spaced 24 in. OC along the studs, starting 2 in. and then 12 in. from the top and bottom of the studs and starting 1-1/4 in. from the horizontal joints when installed horizontally. Outer layer attached to studs with 1-5/8 in. long Type S bugle head screws spaced 16 in. OC along the top and bottom tracks starting 1-3/4 in. from the vertical edge. Outer layer screws spaced 16 in. OC along the studs, starting 1-3/4 in. and then 8 in. from the top and bottom of the studs and starting 1-1/4 in. and then 8 in. from the horizontal joints when installed horizontally. Vertical joints centered over studs and staggered one stud cavity on opposite sides of studs. Vertical joints in adjacent layers staggered one stud cavity. Horizontal joints need not be backed by steel framing. Horizontal edge joints and horizontal butt joints on opposite sides of studs need not be staggered. Horizontal edge joints and horizontal butt joints in adjacent layers staggered a min of 12 in. When outer layers are installed horizontally, vinyl or casein, dry or premixed joint compound shall be applied in two coats to joints and screw heads of outer layer. Paper tape, nom 2 in. wide, embedded in first layer of compound over all joints of outer layer panels. Nom 3/32 in. thick gypsum veneer plaster may be applied to the entire surface of Classified veneer baseboard. Joints reinforced.

GEORGIA-PACIFIC GYPSUM L L C — Types 5, 6, 9, C, DAP, DD, DA, DAPC, DGG, DS, GPFS6, LS, TG-C, Type X, Veneer Plaster Base-Type X, Water Rated-Type X, Sheathing Type-X, Soffit-Type X, GreenGlass Type X, Type X ComfortGuard Sound Deadening Gypsum Board, Type LWX, Veneer Plaster Base-Type LWX, Water Rated-Type LWX, Sheathing Type-LWX, Soffit-Type LWX, Type DGLW, Water Rated-Type DGLW, Sheathing Type- DGLW, Soffit-Type DGLW, Type LW2X, Veneer Plaster Base - Type LW2X, Water Rated - Type LW2X, Sheathing - Type LW2X, Soffit - Type LW2X, Type DGL2W, Water Rated - Type DGL2W, Sheathing - Type DGL2W

4D. **Gypsum Board*** — (Not Shown) — (As an alternate to Item 4 when used as the base layer on one or both sides of wall. For direct attachment only to steel studs Item 2B) — Nom 5/8 in. thick lead backed gypsum panels with beveled, square or tapered edges, applied vertically. Vertical joints centered over studs and staggered min 1 stud cavity on opposite sides of studs. Gypsum board secured to studs with 1-1/4 in. long Type S-12 steel screws spaced 8 in. OC at perimeter and 12 in. OC in the field.

RAY-BAR ENGINEERING CORP — Type RB-LBG

4E. **Gypsum Board*** — (As an alternate to Items 4 through 4D) — Nominal 5/8 in. thick, 4 ft wide panels, applied vertically and secured as described in Item 4.

PABCO BUILDING PRODUCTS L L C, DBA PABCO GYPSUM — Types QuietRock ES

4F. **Gypsum Board*** — (As an alternate to Items 4 through 4E) — 5/8 in. thick, applied vertically or horizontally as the outer layer to one side of the assembly. Horizontal joints need not be backed by steel framing. Secured as described in Item 4 for the direct attached system. When used in widths other than 48 in., gypsum panels to be installed horizontally.

CERTAINTED GYPSUM INC — Type SilentFX

4G. **Gypsum Board*** — As an alternate to Item 4 — Nom. 5/8 in. thick, inner layer attached vertically to studs with 1 in. long Type S steel screws spaced 16 in. OC in the field and along the vertical edges. Outer layer attached to the studs horizontally over the inner layer with 1-5/8 in. long Type S steel screws spaced 16 in. OC in the field and along the vertical edges and 12 in. OC to the floor and ceiling runners. Joints of outer layer must be taped. Nom 3/32 in. thick gypsum veneer plaster may be applied to the entire surface of Classified veneer baseboard.

CABOT MANUFACTURING ULC — Type Blueglass Exterior Sheathing

PABCO BUILDING PRODUCTS L L C, DBA PABCO GYPSUM — Types C, PG-11, PGS-WRS

4H. **Gypsum Board*** — (Not Shown) — (As an alternate to Items 4. For direct attachment only to steel studs Item 2B) — For Direct Application to Studs Only- For use as the base layer on one or both sides of the wall. Nom 5/8 in. thick lead backed gypsum panels with beveled, square or tapered edges, applied vertically. Vertical joints centered over studs and staggered min 1 stud cavity on opposite sides of studs. Wallboard secured to studs with 1-5/8 in. long Type S 12 steel screws spaced 8 in. OC at perimeter and 12 in OC in the field. Lead batten strips required behind vertical joints of lead backed gypsum wallboard and optional at remaining stud locations. Fasteners for face layer gypsum panels when installed over lead backed board to be min 2-1/2 in. Type S-12 bugle head steel screws spaced as described in Item 4. To be used with Lead Batten Strips (see Item 5A) or Lead Discs (see Item 6A).

MAYCO INDUSTRIES INC — Type X-Ray Shielded Gypsum

4I. **Gypsum Board*** — (As an alternate to Item 4, not for use with Items 1C and 2C or 1L and 2N) — Nom. 5/8 in. thick gypsum panels with beveled, square or tapered edges installed as described in Item 4.

CGC INC — Type ULX

UNITED STATES GYPSUM CO — Type ULX

USG MEXICO S A DE C V — Type ULX

4J. **Gypsum Board*** — (As an alternate to Item 4 when used as the base layer on one or both sides of wall. For direct attachment only to steel studs Item 2B) — Nom 5/8 in. thick lead backed gypsum panels with beveled, square or tapered edges, applied vertically. Vertical joints centered over studs and staggered min 1 stud cavity on opposite sides of studs. Wallboard secured to studs with 1-1/4 in. long Type S-12 steel screws gypsum panel steel screws spaced 8 in. OC at perimeter and 12 in. OC in the field. Lead batten strips required behind vertical joints of lead backed gypsum wallboard and optional at remaining stud locations. Lead batten strips, min 2 in. wide, max 8 ft long with a max thickness of 0.14 in. placed on the face of studs and attached to the stud with construction adhesive and two 1 in. long Type S-12 pan head steel screws, one at the top of the strip and one at the bottom of the strip. Lead discs, nominal 3/8 in. diam by max 0.085 in. thick. Compression fitted or adhered over the screw heads. Lead batten strips and discs to have a purity of 99.9% meeting the Federal specification QQ-L-201f, Grade "C".

RADIATION PROTECTION PRODUCTS INC — Type RPP - Lead Lined Drywall

4K. **Gypsum Board** — (As an alternate to Items 4 through 4J, not for use with Items 1C and 2C.) — Two layers of nominal 15 mm thick gypsum board applied vertically. Inner layer attached to studs with No. 3.5 x 1-3/8 in. long bugle head, self-drilling screws spaced 23-5/8 in. OC in the field and 15-3/4 in. OC in the perimeter, with the first screw 2 in. from the edge. Outer layer attached to the studs over the inner layer with No. 3.5 x 1-3/4 in. long bugle head, self-drilling screws spaced 11-13/16 in. OC in the field and 7-7/8 in. OC in the perimeter, with the first screw 3/4 in. from the edge. Outer layer screws staggered from inner layer screws. Vertical joints centered over studs and staggered one stud cavity on opposite sides of studs. Vertical joints in adjacent layer staggered one stud cavity. Self-adhesive fiberglass mesh (9x9 mesh) tape, nom 2 in. wide, applied over all joints of outer layer panels. Dry or premixed joint compound applied in two coats to joints over the mesh tape and screw heads of outer layer.

GYPSEMNA CO LLC — Types MRFW, FW, TF

4L. **Gypsum Board*** — (As an alternate to Items 4 through 4K) — Two layers of 5/8 in. thick gypsum board applied vertically or horizontally. Inner layer attached to studs with #6 x 1 in. long bugle head screws spaced 12 in. OC along the top and bottom tracks and 16 in. OC in the field and along the vertical edges. Outer layer attached to studs with #6 x 1-5/8 in. long bugle head screws spaced 12 in. OC along the top and bottom tracks and 16 in. OC in the field and along the vertical edges. Vertical joints are centered over studs and staggered between layers and on opposite sides of the wall. Horizontal joints on the face layer are staggered 12 in. from the base layer. Horizontal joints need not to be backed by steel framing.

CONTINENTAL BUILDING PRODUCTS OPERATING CO, L L C — Types LGFC2A, LGFC6A, LGFC-C/A, LGFC-WD

4M. **Wall and Partition Facings and Accessories*** — (As an alternate to Items 4 through 4L) — Nominal 5/8 in. thick, 4 ft wide panels, applied vertically and secured as described in Item 4.

PABCO BUILDING PRODUCTS L L C, DBA PABCO GYPSUM — Type QuietRock 527.

4N. Gypsum Board* — (As an alternate to Item 4 through 4M) — For direct application to studs only - Four layers nom. 5/16 in. thick gypsum panels applied vertically or horizontally. When applied horizontally, base layer secured to studs with 1 in. Type S screws spaced 24 in. OC. Second layer installed with joints offset 12 in. from base layer and secured with 1 in. Type S screws spaced 24 in. OC. Third layer installed with joints in line with base layer and secured with 1-1/2 in. Type S screws spaced 16 in. OC. Fourth layer installed with joints in line with second layer and secured with 1-5/8 in. Type S screws spaced 12 in. OC. For all layers, screws offset 4 in. from previous layer. When applied vertically, base layer secured with 1 in. Type S screws spaced 24 in. OC. Second layer secured with joints offset one stud cavity and secured with 1 in. Type S screws spaced 24 in. OC. Third layer installed with joints in line with base layer and secured with 1-1/2 in. Type S screws spaced 12 in. OC. Fourth layer secured with joints in line with second layer and secured with 1-5/8 in. Type S screws spaced 8 in. OC along vertical edges and 12 in. OC in the field. For all layers, screws offset 4 in. from previous layer.

NATIONAL GYPSUM CO — Type FSW

4O. Gypsum Board* — (As an alternate to Items 4 through 4N) — Two layers of 5/8 in. thick gypsum board applied vertically or horizontally. Inner layer attached to studs with 1 in. long Type S screws spaced 16 in. OC in the field and vertical edges and along top and bottom tracks. Outer layer attached to studs with 1-5/8 in. long Type S screws spaced 16 in. OC in the field and vertical edges and along the top and bottom tracks. Vertical joints are centered over studs and staggered between layers and on opposite sides of studs. Horizontal edge joints and horizontal butt joints on opposite sides of studs need not be staggered or backed by steel framing. Horizontal edge joints and horizontal butt joints in adjacent layers need not be staggered.

NATIONAL GYPSUM CO — Type FSLX

4P. Wall and Partition Facings and Accessories* — (As an alternate to Item 4) — Nominal 1-3/8 in. thick, 4 ft wide panels, applied vertically or horizontally. Fastened with #6 x 2 in. long drywall screws spaced 8 in. OC along the perimeter and 12 in. OC in the field.

PABCO BUILDING PRODUCTS L L C, DBA PABCO GYPSUM — Type QuietRock 545

5. Lead Batten Strips — (Not Shown, For Use With Item 4D) — Lead batten strips, min 1-1/2 in. wide, max 10 ft long with a max thickness of 0.125 in. Strips placed on the interior face of studs and attached from the exterior face of the stud with two 1 in. long Type S-12 pan head steel screws, one at the top of the strip and one at the bottom of the strip. Lead batten strips to have a purity of 99.9% meeting the Federal specification QQ-L-201f, Grade "C". Lead batten strips required behind vertical joints of lead backed gypsum board (Item 4D) and optional at remaining stud locations. Required behind vertical joints.

5A. Lead Batten Strips — (Not Shown, for use with Item 4H) — Lead batten strips, 2 in. wide, max 10 ft long with a max thickness of 0.140 in. Strips placed on the face of studs and attached to the stud with two min. 1 in. long min. Type S-8 pan head steel screws, one at the top of the strip and one at the bottom of the strip or with one min. 1 in. long min. Type S-8 pan head steel screw at the top of the strip. Lead batten strips to have a purity of 99.5% meeting the Federal specification QQ-L-201f, Grades "B, C or D". Lead batten strips required behind vertical joints of lead backed gypsum wallboard (Item 6) and optional at remaining stud locations.

6. Lead Discs or Tabs — (Not Shown, For Use With Item 4D) — Used in lieu of or in addition to the lead batten strips (Item 5) or optional at other locations - Max 3/4 in. diam by max 0.125 in. thick lead discs compression fitted or adhered over steel screw heads or max 1/2 in. by 1-1/4 in. by max 0.125 in. thick lead tabs placed on gypsum boards

(Item 4D) underneath screw locations prior to the installation of the screws. Lead discs or tabs to have a purity of 99.9% meeting the Federal specification QQ-L-201f, Grade "C".

6A. **Lead Discs** — (Not Shown, for use with Item 4H) — Max 5/16 in. diam by max 0.140 in. thick lead discs compression fitted or adhered over steel screw heads. Lead discs to have a purity of 99.5% meeting the Federal Specification QQ-L-201f, Grades "B, C or D".

7. **Mineral and Fiber Board*** — (Optional, Not Shown) — For optional use as an additional layer on one side of wall. Nom 1/2 in. thick, 4 ft wide with long dimension parallel and centered over studs. Attached to studs and floor and ceiling runners with 1-5/8 in. long Type S steel screws, spaced 12 in. OC. The required UL Classified gypsum board layer(s) is/are to be installed as indicated as to fastener type and spacing, except that the required fastener length shall be increased by a minimum of 1/2 in. Not evaluated or intended as a substitute for the required layer(s) of UL Classified Gypsum Board.

HOMASOTE CO — Homasote Type 440-32

7A. **Mineral and Fiber Board** — (Optional, Not Shown) — For optional use as an additional layer on one side of wall - Nom 1/2 in. thick, 4 ft wide, square edge fiber boards applied vertically to studs on one side of the wall in between the wood studs and the UL Classified Gypsum Board (Item 4). Fiber boards installed with 1-1/4 in. long, Type S steel screws spaced 12 in. OC max, with the last screws spaced 2 in. and 6 in. from edge of board. Gypsum board (Item 4) installed as indicated as to fastener type and spacing, except that the required fastener length shall be increased by a minimum of 1/2 in. Not evaluated or intended as a substitute for the required layer(s) of UL Classified Gypsum Board.

BLUE RIDGE FIBERBOARD INC — SoundStop

8. **Furring Channels** — (Optional, Not Shown — not for use with Items 4D, 4H, 4J, or 4N) — Resilient furring channels fabricated from min 25 MSG corrosion-protected steel, spaced vertically a max of 24 in. OC. Flange portion attached to each intersecting stud with 1/2 in. long Type S-12 steel screws.

8A. **Framing Members*** — (Optional on one or both sides, Not Shown — not for use with Items 4D, 4H, 4J, or 4N) — As an alternate to Item 8, furring channels and Steel Framing Members as described below:

a. **Furring Channels** — Formed of No. 25 MSG galv steel. 2-9/16 in. or 2-23/32 in. wide by 7/8 in. deep, spaced max. 24 in. OC perpendicular to studs. Channels secured to studs as described in Item b.

b. **Steel Framing Members*** — Used to attach furring channels (Item 8Aa) to studs. Clips spaced max. 48 in. OC. RSIC-1 and RSIC-1 (2.75) clips secured to studs with No. 8 x 1-1/2 in. minimum self-drilling, S-12 steel screw through the center grommet. RSIC-V and RSIC-V (2.75) clips secured to studs with No. 8 x 9/16 in. minimum self-drilling, S-12 steel screw through the center hole. Furring channels are friction fitted into clips. RSIC-1 and RSIC-V clips for use with 2-9/16 in. wide furring channels. RSIC-1 (2.75) and RSIC-V (2.75) clips for use with 2-23/32 in. wide furring channels.

PAC INTERNATIONAL L L C — Types RSIC-1, RSIC-V, RSIC-1 (2.75), RSIC-V (2.75)

8B. **Framing Members*** — (Optional on one or both sides, Not Shown — Not for use with Items 4D, 4H, 4J, or 4N) — As an alternate to Item 8, furring channels and Steel Framing Members as described below:

a. **Furring Channels** — Formed of No. 25 MSG galv steel. Spaced 24 in. OC perpendicular to studs. Channels secured to studs as described in Item b. Ends of adjoining channels overlapped 6 in. and tied together with double strand of No. 18 AWG galvanized steel wire. Gypsum board attached to furring channels as described in Item 4.

b. **Steel Framing Members*** — Used to attach furring channels (Item a) to studs. Clips spaced 48 in. OC., and secured to studs with 2 in. coarse drywall screw with 1 in. diam washer through the center hole. Furring channels are friction fitted into clips.

STUDCO BUILDING SYSTEMS — RESILMOUNT Sound Isolation Clips - Type A237R

8C. **Steel Framing Members*** — (Optional on one or both sides, Not Shown — Not for use with Items 4D, 4H, 4J, or 4N) — As an alternate to Item 8, furring channels and Steel Framing Members as described below:

a. **Furring Channels** — Formed of No. 25 MSG galv steel. Spaced 24 in. OC perpendicular to studs. Channels secured to studs as described in Item 8Cb. Ends of adjoining channels overlapped 6 in. and tied together with double strand of No. 18 AWG galvanized steel wire. Gypsum board attached to furring channels as described in Item 4.

b. **Steel Framing Members*** — Used to attach furring channels (Item 8Ca) to studs. Clips spaced 48 in. OC, and secured to studs with No. 8 x 2-1/2 in. coarse drywall screw through the center hole. Furring channels are friction fitted into clips.

REGUPOL AMERICA — Type SonusClip

8D. **Steel Framing Members*** — (Optional on one or both sides, Not Shown — Not for use with Items 4D, 4H, 4J, or 4N) — As an alternate to Item 8, furring channels and Steel Framing Members as described below:

a. **Resilient Channels** — Formed of No. 25 MSG galv steel, spaced 24 in. OC, and perpendicular to studs. Channels secured to studs as described in Item b. Ends of adjoining channels overlapped 6 in. and secured in place with two No. 8 15 x 1/2 in. Philips Modified Truss screws spaced 2-1/2 in. from the center of the overlap. Gypsum board attached to resilient channels as described in Item 4.

b. **Steel Framing Members*** — Used to attach resilient channels (Item 8Da) to studs. Clips spaced 48 in. OC., and secured to studs with No. 8 x 2-1/2 in. coarse drywall screw through the center hole. Resilient channels are secured to clips with one No. 10 x 1/2 in. pan-head self-drilling screw.

KEENE BUILDING PRODUCTS CO INC — Type RC+ Assurance Clip

8E. **Steel Framing Members*** — (Optional on one or both sides, Not Shown — Not for use with Items 4D, 4H, 4J, or 4N) — As an alternate to Item 8, furring channels and Steel Framing Members as described below:

a. **Furring Channels** — Formed of No. 25 MSG galv steel. Spaced 24 in. OC perpendicular to studs. Channels secured to studs as described in Item b. Ends of adjoining channels overlapped 6 in. and tied together with double strand of No. 18 AWG galvanized steel wire. Gypsum board attached to furring channels as described in Item 4.

b. **Steel Framing Members*** — Used to attach furring channels (Item 8Ea) to studs. Clips spaced 48 in. OC., and secured to studs with No. 10 x 2 in. screw through the center hole. Furring channels are friction fit into clips.

MASON INDUSTRIES INC — Type CWC-50

8F **Steel Framing Members*** — (Optional on one or both sides, Not Shown — Not for use with Items 4D, 4H, 4J, or 4N) — As an alternate to Item 8, furring channels and Steel Framing Members as described below:

a **Furring Channels** — Formed of No. 25 MSG galv steel. 2-23/32 in. wide by 7/8 in. or 1-1/2 in. deep, spaced 24 in. OC perpendicular to studs. Channels secured to studs as described in Item b. Ends of adjoining channels

are overlapped 6 in. and tied together with double strand of No. 18 SWG galv steel wire near each end of overlap. As an alternate, ends of adjoining channels may be overlapped 6 in. and secured together with two self-tapping #6 framing screws, min. 7/16 in. long at the midpoint of the overlap, with one screw on each flange of the channel. Gypsum board attached to furring channels as described in Item 4.

b **Steel Framing Members*** — Used to attach furring channels (Item 8Fa) to studs. Clips spaced maximum 48 in. OC. Clips secured to studs with No. 8 x 2-1/2 in. coarse drywall screw through the center grommet. Furring channels are friction fitted into clips.

CLARKDIETRICH BUILDING SYSTEMS — Type ClarkDietrich Sound Clip

9. **Barrier Mesh** — (Optional, Not Shown) - Attached to steel studs on one or both sides of the wall using Barrier Mesh Clips spaced at maximum 12 inches on center vertically, using a flat head type screw penetrating through the steel at least 3/8 of an inch. For Steel Studs less than 0.033 inches in thickness, use self-piercing screws. For Steel Studs equal to or greater than 0.033 inches in thickness, use steel drill screws (self-tapping). Gypsum Board (Item 4) to be installed directly over the Barrier Mesh using prescribed screw patterns with lengths increased by a minimum 1/8 in. Barrier Mesh may be installed with the long dimension of the diamond pattern positioned vertically or horizontally. Barrier Mesh joints may occur as butt joints at the framing members and secured using the Barrier Mesh Clips or occur in between framing members as overlapping joints secured using 18 SWG wire ties spaced a maximum 12 in. on center.

CLARKDIETRICH BUILDING SYSTEMS — Barrier Mesh, Barrier Mesh Clips

*** Indicates such products shall bear the UL or cUL Certification Mark for jurisdictions employing the UL or cUL Certification (such as Canada), respectively.**

[Last Updated](#) on 2020-10-13