

Design No. P573

June 01, 2020

Restrained Assembly Rating - 1, 2 Hr (see Item 5, 5A, and 5B)

Unrestrained Assembly Rating - 1, 2 Hr

This design was evaluated using a load design method other than the Limit States Design Method (e.g., Working Stress Design Method). For jurisdictions employing the Limit States Design Method, such as Canada, a load restriction factor shall be used — See Guide [BXUV](#) or [BXUV7](#)

** Indicates such products shall bear the UL or cUL Certification Mark for jurisdictions employing the UL or cUL Certification (such as Canada), respectively.*

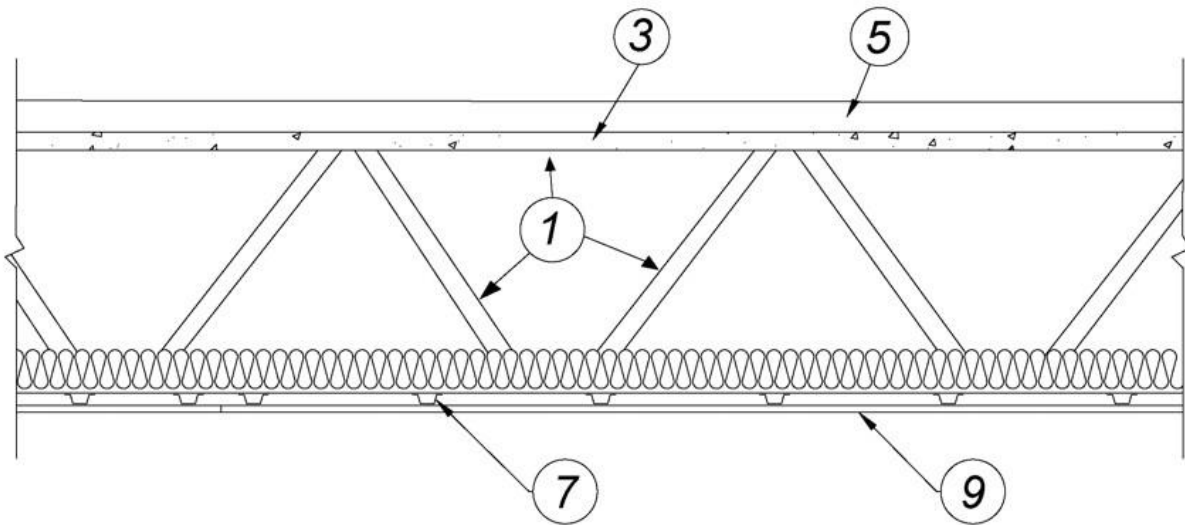

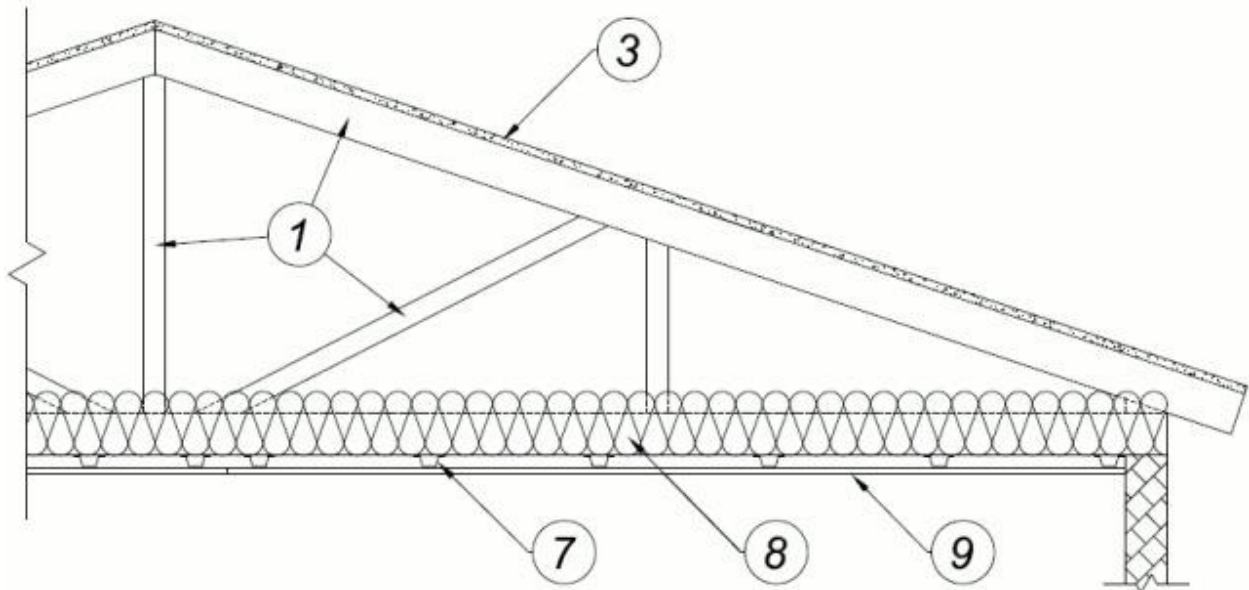
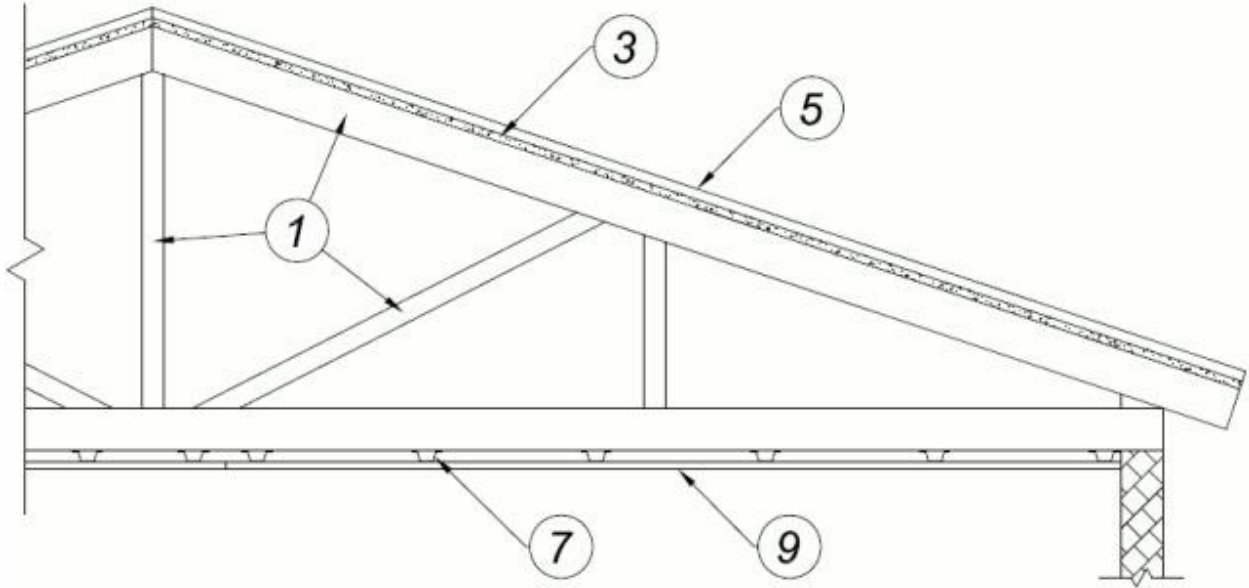

1. **Structural Steel Members*** — Pre-fabricated light gauge steel truss system consisting of cold-formed, galvanized steel cord and web sections. Trusses fabricated in various sizes, depths, and from various steel thickness. Trusses minimum 12 in. deep, spaced a max of 48 in. OC.

AEGIS METAL FRAMING, DIV OF MITEK — Ultra-Span, Pre-fabricated Light Gauge Steel Truss System

TRUSSTEEL, DIV OF ITW BUILDING COMPONENTS INC — TrusSteel

1A. **Steel Roof Trusses** — As an alternate to Item 1 - Cold-formed galvanized steel truss chord and web sections manufactured from steel conforming to ASTM A653 Grade 33 or higher yield strength. Steel thickness of truss chord and web sections as required by design to meet governing code requirements. Truss members connected together with No. 10-16 (min size) self-drilling screws or equivalent. Truss chord and web members to be designed in accordance with the American Iron and Steel Institute's Specification for the Design of Cold-Formed Steel Structural Members, 1996 Edition. Trusses spaced a max of 48 in. OC. Where the truss intersects with the interior face of the exterior walls, the min truss depth shall be 12 in.

1B. **Steel Joists** — As an alternate to Item 1 or 1A, minimum 12K1, spaced a max 48 in. OC.

1C. **Structural Steel Members*** — ((Not Shown) - As an alternate to Item 1, 1A, and 1B, - Pre-fabricated steel truss system consisting of cold-formed, galvanized steel chord and web sections. Truss top and bottom chords min. 4 in. high by 1-11/16 in. wide by 18 ga. Truss webs min. 1-1/2 in. by 1-1/2 in. by 20 ga. square tube bent and triangulated as shown. Chords and web connected by fillet welds. Minimum truss depth min. 12 in. Trusses spaced a max of 24 in. OC. Truss ends placed over and secured to Bearing Seats (Item 1C1) with two min. #10 by 3/4 in. long screws on each side of Bearing Seats. Allowable loading must be calculated so as to stress the steel trusses to a maximum of 98% of the stress calculated in accordance with the allowable stress design approach outlined in the manufacturer's load tables.

EISEN PANEL SYSTEMS L L C — Type Gateway Panel pre-fabricated steel truss system.

1C1. **Bearing Seats*** — (Not Shown) — Galvanized steel tube, min. 1 in. by 2-1/2 in. by 13 ga., oriented vertically and welded to min. 4 in. by 4 in. by 10 ga., galvanized steel plate. Bearing seats spaced 24 in. OC and attached to bearing supports by welding or screw attaching the steel plate to the bearing supports.

EISEN PANEL SYSTEMS L L C — Type Gateway Panel bearing seat.

1C2. **Bracing** — (Not Shown) - For use with Item 1C — Galvanized channel-shaped steel sections, min. 1-1/2 in. wide with 1/4 in. flanges, min. 16 ga. Bracing attached to underside of trusses with min. #10 by 3/4 in. long screws through truss bottom chord. Bracing installed in truss cavities by scoring, bending and flattening the ends to form a tab for attachment to truss top and bottom chords. Two pieces of bracing crossed and tabs secured to truss chords

with min. #10 by 3/4 in. long screws. Location and spacing of underside and crossed bracing to be specified on truss engineering.

1D. Structural Steel Members* — As an alternate to Item 1 - Limited to the 1 Hour Ratings. Pre-fabricated light gauge steel truss system consisting of cold-formed, galv steel cord and web sections. Trusses fabricated in various sizes, depths and from various steel thickness. Trusses spaced a max of 24 in. OC. Location of lateral bracing for truss chord and web sections to be specified on truss engineering.

TRUSS LINK INC — Truss Link

2. Bridging — (Not Shown) — Location of lateral bracing for truss chord and web sections to be specified on truss engineering.

3. Structural Cement-Fiber Units* — Nom 3/4 in. thick, square or T&G edge, with long dimension of panels to be perpendicular to truss with end joints staggered a min of 4 ft and centered over the trusses. Panels secured to steel trusses with 1-5/8 in. long No. 8 self-drilling, self-countersinking steel screws spaced a max of 12 in. OC in the field with a screw located 1 in. from each edge, and 8 in. OC at the perimeter, screw attached to the runner track (Item 4), located 1 in. from the edge. At the end joints, screws 8 in. OC with a screw located 2 in. from each edge, located 1/2 in. from the end edges of the panel.

As an alternate to the 1-5/8" long No. 8 fastener, the following power-actuated pins may be used for min. 1/8" thick, hot-rolled A36 steel sections for joist specified in Item 1B:

Hilti pin model X-U 32MX with a min. 0.157" shank diameter min. 1-1/4" long, DeWalt pin model 50458-PWR with a min. 0.157" shank diameter min. 1-1/4" long or Aerosmith model 5324HPG with a min. 0.145 shank diameter min. 1-1/4" long. Note that these pins shall not be used to fasten the cement panels to the runner track (Item 4).

UNITED STATES GYPSUM CO — Types STRUCTO-CRETE, USGSP.

4. Runner Track — For use with Item 3 - Not Shown - Channel shaped runners, min 3-5/8 deep, 1-1/4 in. legs, formed from min No. 16 MSG galv steel, centered and located under all long structural cement-fiber unit (Item 3) joints perpendicular to trusses. Runner tracks ends centered and butted together over truss and legs notched to allow runner track to lay flat on top of truss upper chord. Runner track not attached to truss except when screws from attachment of structural cement-fiber unit penetrate both runner track and truss.

5. Roof Insulation — Foamed Plastic* — Any polyisocyanurate foamed plastic insulation boards bearing the UL Classification Marking. No min thickness for the 1 hr assembly ratings. Min thickness is 1 in. for the 2 hr assembly rating, with no limit on max overall thickness. As

an alternate to roof insulation, min. 6 in. batts and blankets (Item 8) shall be fitted in the concealed space, draped over the furring channels for the 2 hr rating. Boards installed over the structural cement-fiber units (Item 3), with the end-joints staggered in adjacent rows. When applied in more than one layer, each layer of board to be offset from layer below in order to lap all joints. Boards loosely laid, adhered or mechanically fastened to structural cement-fiber units (Item 3). See Foamed Plastic (CCVW) Category in the Fire Resistance Directory.

5A. Roof Insulation — Foamed Plastic* — (Not Shown) As an alternate to Item 5 Any polystyrene foamed plastic insulation boards bearing the UL Classification Marking. No min thickness for the 1 hr assembly ratings. Min thickness is 1 in. for the 2 hr assembly rating with no limit on max overall thickness. As an alternate to roof insulation, min. 6 in. batts and blankets (Item 8) shall be fitted in the concealed space, draped over the furring channels for the 2 hr rating. Boards installed over the structural cement-fiber units (Item 3) with the end-joints staggered in adjacent rows. Boards loosely laid, adhered or mechanically fastened to cement-fiber units (Item 3). See Foamed Plastic (BRYX) category in the Building Materials Directory or Foamed Plastic (CCVW) category in the Fire Resistance Directory.

5B. Roof Insulation — Mineral and Fiber Boards* — (Not Shown) — As an alternate to Item 5 — Mineral wool, glass fiber or perlite insulation boards, 24 by 48 in. min size. No min thickness for the 1 hr assembly ratings. Min thickness is 1 in. for the 2 hr assembly rating with no limit on max overall thickness. As an alternate to roof insulation, min. 6 in. batts and blankets (Item 8) shall be fitted in the concealed space, draped over the furring channels for the 2 hr rating. Boards installed over the structural cement-fiber units (Item 3) with the end-joints staggered in adjacent rows. Boards loosely laid, adhered or mechanically fastened to cement-fiber units (Item 3). See **Mineral and Fiber Boards** (BQXR) Category in the Building Materials Directory or **Mineral and Fiber Boards** (CERZ) Category in the Fire Resistance Directory.

5C. Roof Cover Board - Gypsum Board* (Not Shown) — As an alternate to Item 5 for a 2 hr rating. Min 1/2 in. thick (one layer), 4 ft by 4 ft gypsum roof cover board, adhered or mechanically fastened with a minimum of 5 fasteners per board.

UNITED STATES GYPSUM CO — Type FRX-G

5D. Roof Cover Board - Gypsum Board* (Not Shown) — As an alternate to Item 5 for a 2 hr rating. Min 1/2 in. thick (one layer), 4 ft by 4 ft gypsum roof cover board, adhered or mechanically fastened with a minimum of 5 fasteners per board.

UNITED STATES GYPSUM CO — Type SGMRX

5E. **Roof Cover Board - Cementitious Backer Units* (Not Shown)** — As an alternate to Item 5 for a 2 hr rating. Min 1/2 in. thick (one layer), 4 ft by 4 ft gypsum roof cover board, adhered or mechanically fastened with a minimum of 5 fasteners per board.

UNITED STATES GYPSUM CO — Type DCB

6. **Roofing Membrane*** — (Not Shown)—Single-ply membrane that is either ballasted, adhered or mechanically attached to the insulation(s) described herein as permitted under the respective company's Classification. See Fire Resistance Directory, Roofing Membranes (CHCI) category.

7. **Furring Channels** — Hat channels min 25 MSG galv steel, min 2-5/8 in. wide by min 7/8 in. deep, installed perpendicular to the trusses (Item 1), spaced a max of 12 in. OC when batts and blankets (item 8) or loose fill material (item 8A) are used and a max of 16 in. OC when they are not. Two courses of channel positioned 6 in. OC, 3 in. on each side of gypsum board end joints. Channel splices overlapped 4 in. beneath steel trusses. Channels secured to each truss with No. 18 SWG steel wire double strand saddle ties.

7A. **Steel Framing Members** — Not Shown -As an alternate to Item 7

a. **Main runners** — Installed perpendicular to Structural Steel Members — Nom 10 or 12 ft long, 5/16 in. or 1-1/2 in. wide face, spaced 4 ft OC. Main runners hung a min of 2 in. from bottom chord of Structural Steel Members with 12 SWG galv steel wire. Wires located a max of 48 in. OC.

b. **Cross tees or channels** — Nom 4 ft long, 15/16 in. or 1-1/2 in. wide face or cross channels, nom 4 ft long, 1-1/2 in. wide face, installed perpendicular to the main runners, spaced 16 in. OC. Additional cross tees or channels used at 8 in. from each side of butted gypsum board end joints. The cross tees or channels may be riveted or screw-attached to the wall angle or channel to facilitate the ceiling installation.

c. **Wall angles or channels** — Used to support steel framing member ends and for screw-attachment of the gypsum board — Min 0.016 in. thick painted or galvanized steel angle with 1 in. legs or min. 0.016 in. thick painted or galvanized steel channel with a 1 by 1-1/2 by 1 in. profile, attached to walls at perimeter of ceiling with fasteners 16 in. OC.

USG INTERIORS LLC — Type DGL or RX.

7B. **Alternate Steel Framing Members*** — (Not Shown) - As an alternate to Item 7A - Not for use with Items 8 or 8A - Main runners nom 12 ft long, spaced 72 in. OC. Main runners suspended by min 12 SWG galv steel hanger wires spaced 48 in. OC. Cross tees, nom 6 ft

long, installed perpendicular to main runners and spaced 24 in. OC. Additional 6 ft long cross tees required at each gypsum board end joint with butted gypsum board end joints centered between cross tees spaced 8 in. OC. The main runners and cross tees may be riveted or screw attached to the wall angle or channel to facilitate the ceiling installation.

USG INTERIORS LLC — Type DGL or RX

7C. Steel Framing Members* - (Not Shown) — As an alternate to Items 7 to 7B, furring channels and Steel Framing Members* as described below:

a. **Furring Channels** — — Formed of No. 25 MSG galv steel, 2-9/16 in. or 2-23/32 in. wide by 7/8 in. deep, installed perpendicular to the trusses (Item 1), spaced a max of 12 in. OC when batts and blankets (Item 8) or loose fill material (Item 8A) are used and a max of 16 in. OC when they are not. Channels secured to trusses as described in Item b. Ends of adjoining channels overlapped 6 in. and tied together with double strand of No. 18 SWG galv steel wire near each end of overlap.

b. **Steel Framing Members*** — Used to attach furring channels (Item a) to the steel joists (Item 1). Clips spaced a max of 48 in. OC. RSIC-1 and RSIC-1 (2.75) clips secured to alternating joists with No. 8 x 2-1/2 in. coarse drywall screw through the center grommet. Furring channels are friction fitted into clips. RSIC-1 clips for use with 2-9/16 in. wide furring channels. RSIC-1 (2.75) clips for use with 2-23/32 in. wide furring channels. Adjoining channels are overlapped as described in Item a. As an alternate, ends of adjoining channels may be overlapped 6 in. and secured together with two self-tapping No. 6 framing screws, min. 7/16 in. long at the midpoint of the overlap, with one screw on each flange of the channel. Additional clips required to hold furring channel that supports the wallboard butt joints, as described in Item 9.

PAC INTERNATIONAL L L C — Types RSIC-1 or RSIC-1 (2.75)

8. Batts and Blankets — Optional — Any thickness mineral wool or glass fiber insulation bearing the UL Classification Marking for Surface Burning Characteristics, having a flame spread value of 25 or less and a smoke spread value of 50 or less. Insulation fitted in the concealed space, draped over the resilient channel/gypsum board ceiling membrane.

8A. Loose Fill Material — Optional — As an alternate to Item 8 - Any thickness of loose fill material bearing the UL Classification Marking for Surface Burning Characteristics, having a flame spread value of 25 or less and a smoke spread value of 50 or less. Insulation fitted in the concealed space, draped over the resilient channel/gypsum board ceiling membrane.

9. **Gypsum Board*** — One layer of nom 5/8 in. thick by 48 in. wide boards, installed with long dimension parallel to trusses. Attached to the furring channels using 1 in. long Type S bugle-head screws spaced 12 in. OC along butted end-joints and 12 in. OC in the field when no insulation (Item 8 or 8A) is fitted in the concealed space or a max 8 in. OC along butted end-joints and in the field when insulation (Item 8 or 8A) is fitted in the concealed space, draped over the furring channel/gypsum board ceiling membrane. When **Steel Framing Members** (Item 7C) is used, the butt joints in the gypsum board shall be supported by two furring channels. The two furring channels shall be spaced approximately 3-1/2 in. OC, and be attached to underside of the joist with one RSIC-1 or RSIC-1 (2.75) clip at each end of the channel. Gypsum board attached to the furring channels using 1 in. long Type S bugle-head screws spaced 8 in. OC along butted end-joints and 12 in. OC in the field when no insulation (Item 8 or 8A) is fitted in the concealed space.

UNITED STATES GYPSUM CO — Type C

CGC INC — Type ULIX

UNITED STATES GYPSUM CO — Type ULIX

10. **Gypsum Board*** — For use with **Steel Framing Members** (Item 7A or 7B) when **Batts and Blankets*** (Item 8 or 8A) are not used - One layer of nominal 5/8 in. thick by 48 in. wide boards, installed with long dimension parallel to the main runners. Gypsum board fastened to each cross tee or channel with five gypsum board screws, with one screw located at the mid-span of the cross tee or channel, one screw located 12 in. from and on each side of the cross tee or channel mid-span, and one screw located 1-1/2 in. from each gypsum board side joint, Except at gypsum board end joints, gypsum board screws shall be located on alternating sides of cross tee flange. At gypsum board end joints, gypsum board screws shall be located 1/2 in. from the joint. Gypsum board fastened to main runners with gypsum board screws 1/2 in. from side joints, midway between intersections with cross tees or channels (16 in. OC). End joints of adjacent gypsum board sheets shall be staggered not less than 32 in. Gypsum board sheets screw attached to leg of wall angle with gypsum board screws spaced 12 in. OC. Joints treated as described in Item 10. For use with **Steel Framing Members*** (Item 7A) when **Batts and Blankets*** (Item 8) are used - - Ratings limited to 1 Hour- 5/8 in. thick, 4 ft wide; installed with long dimension perpendicular to cross tees with side joints centered along main runners and end joints centered along cross tees. Fastened to cross tees with 1 in. long steel gypsum board screws spaced 8 in. OC in the field and 8 in. OC along end joints. Fastened to main runners with 1 in. long gypsum board screws spaced midway between cross tees. Screws along sides and ends of boards spaced 3/8 to 1/2 in.

from board edge. End joints of the sheets shall be staggered with spacing between joints on adjacent boards not less than 4 ft OC.

UNITED STATES GYPSUM CO — Type C

10A. **Gypsum Board*** — For use with **Steel Framing Members*** (Item 7A) when max 3-1/2 in. **Batts and Blankets*** (Item 8) are used - - Ratings limited to 1 Hour- 5/8 in. thick, 4 ft wide; installed with long dimension perpendicular to cross tees with side joints centered along main runners and end joints centered along cross tees. Fastened to cross tees with 1 in. long steel gypsum board screws spaced 8 in. OC in the field and 8 in. OC along end joints. Fastened to main runners with 1 in. long gypsum board screws spaced midway between cross tees. Screws along sides and ends of boards spaced 3/8 to 1/2 in. from board edge. End joints of the sheets shall be staggered with spacing between joints on adjacent boards not less than 4 ft OC.

CGC INC — Type ULIX

UNITED STATES GYPSUM CO — Type ULIX

11. **Finishing System** — (Not Shown) — Vinyl, dry of premixed joint compound, applied in two coats to joints and screw heads, paper tape, 2 in. wide, embedded in first layer of compound over all joints.

** Indicates such products shall bear the UL or cUL Certification Mark for jurisdictions employing the UL or cUL Certification (such as Canada), respectively.*

[Last Updated](#) on 2020-06-01