

Design No. P545

February 15, 2023

Unrestrained Assembly Rating — 1 Hr.

Finish Rating — 24 or 25 Min (See Items 3 and 3A)

This design was evaluated using a load design method other than the Limit States Design Method (e.g., Working Stress Design Method). For jurisdictions employing the Limit States Design Method, such as Canada, a load restriction factor shall be used — See Guide [BXUV](#) or [BXUV7](#)

* Indicates such products shall bear the UL or cUL Certification Mark for jurisdictions employing the UL or cUL Certification (such as Canada), respectively.

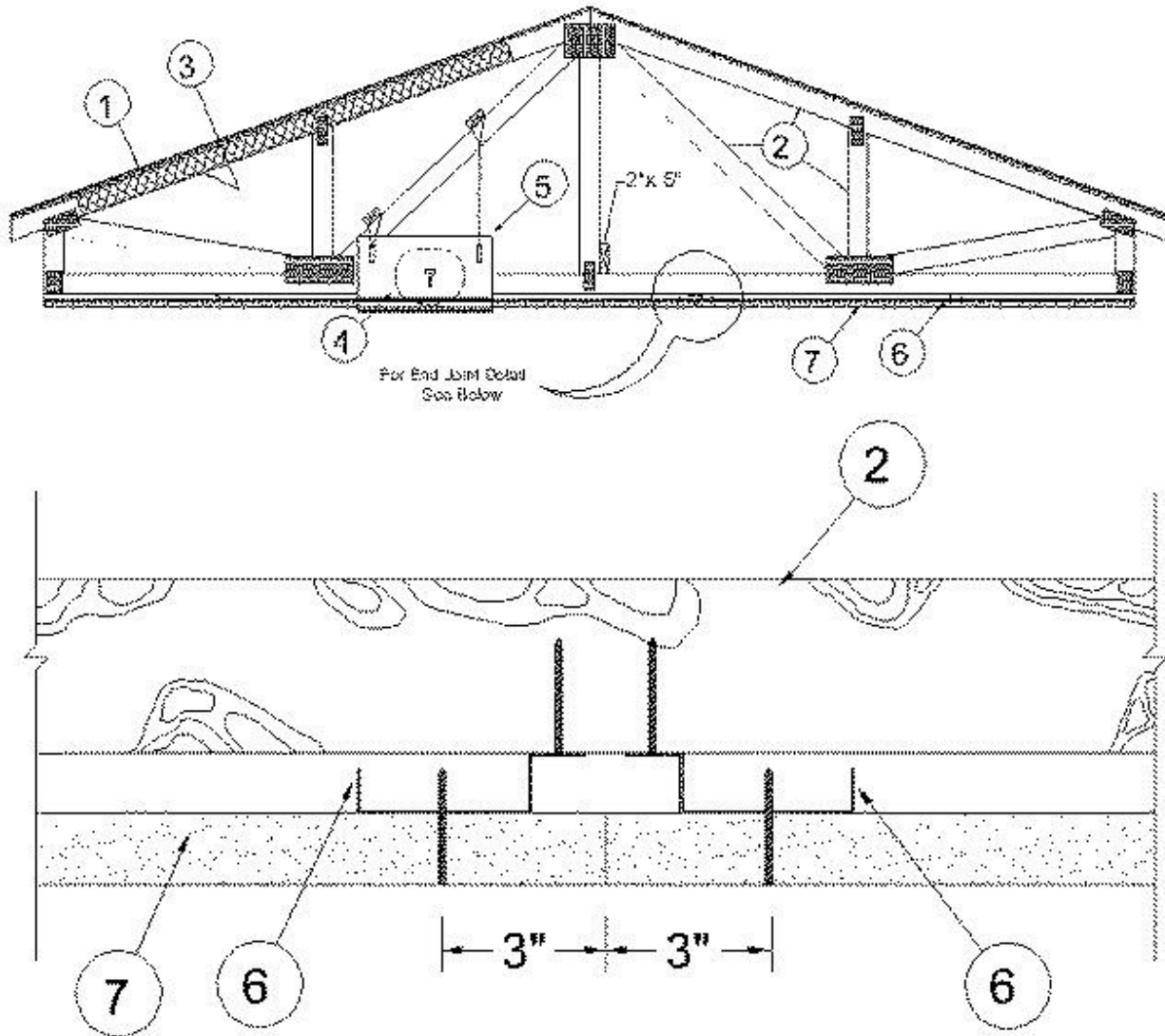

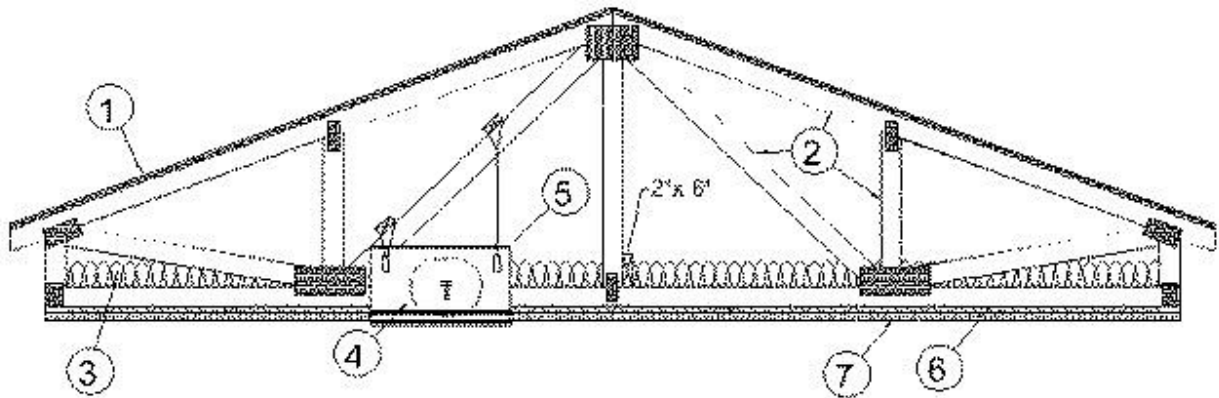

Alternate Insulation Placement

1. **Roofing System*** — Any UL Class A, B or C Roofing System (**TGFU**) or Prepared Roof Covering (**TFWZ**) acceptable for use over nom 15/32 in. thick wood structural panels, min. grade "C-D" or "Sheathing". Nom 15/32 in. thick wood structural panels secured to trusses with No. 6d ringed shank nails. Nails spaced 12 in. OC along each truss. Staples having equal or greater withdrawal and lateral resistance strength may be substituted for the 6d nails. Construction adhesive is optional.

2. **Trusses** — Pitch chord trusses, spaced a max of 24 in. OC, fabricated from nom 2 by 4 lumber, with lumber oriented vertically or horizontally. Truss members secured together min. 0.0356 in. thick galv steel plates. Plates have 5/16 in. long teeth projecting perpendicular to the plane of the plate. The teeth are in pairs facing each other (made by the same punch), forming a split tooth type plate. Each tooth has a chisel point on its outside edge. These points are diagonally opposite each other for each pair. The top half of each tooth has a twist for stiffness. The pairs are repeated on approximately 7/8 in. centers with four rows of teeth per inch of plate width. Where the truss intersects with the interior face of the exterior walls, the min truss depth shall be 5-1/4 in. and a min. average depth of 18 in.. Where the truss intersects with the interior face of the exterior walls, the min truss depth may be reduced to 3 in. if the batts and blankets (Item 3) are used as shown in the above illustration (Alternate Insulation Placement) and are firmly packed against the intersection of the bottom chords and the plywood sheathing. Min roof slope of 3/12 unless American Gypsum boards are used, in which case there is no minimum slope.

3. **Batts and Blankets*** — (Optional) — Glass fiber insulation, secured to the wood structural panels with staples spaced 12 in. OC or to the trusses with 0.090 in. diam galv steel wires spaced 12 in. OC. Any glass fiber insulation bearing the UL Classification Marking as to Surface Burning Characteristics and/or Fire Resistance, having a min density of 0.5 pcf. As an option, the insulation may be fitted in the concealed space, draped over the resilient channel/gypsum wallboard ceiling membrane when resilient channels and gypsum wallboard attachment is modified as specified in Items 6 and 7. The Finish Rating is 24 min. when the insulation is draped over the resilient channels and gypsum board ceiling membrane and 25 min. when it is installed on underside of the plywood deck or when it is omitted.

When Type AG-C panels are installed there is no limit on maximum thickness.

When Type TG-C panels are installed the maximum thickness is 3-1/2 in.

3A. **Loose Fill Material*** — As an alternate to Item 3 — Loose fill material bearing the UL Classification Marking for Surface Burning Characteristics, having a min density of 0.5 pcf, fitted in

the concealed space, draped over the resilient channel/gypsum wallboard ceiling membrane when resilient channels and gypsum wallboard attachment is modified as specified in Items 6 and 7. The finished rating when this insulation is used has not been determined.

When Type AG-C panels are installed there is no limit on maximum thickness.

When Type TG-C panels are installed the maximum thickness is 3-1/2 in.

3B. Fiber, Sprayed* — For Use With American Gypsum Type AG-C only. As an alternate to Item 3 (not evaluated for use with Item 6B and 6C) — spray-applied cellulose insulation material, having a min density of 0.5 lb/ft³, applied with water, over the resilient channel/gypsum board ceiling membrane when resilient channels and gypsum board attachment is modified as specified in Items 6 and 7. Fiber, Sprayed is applied with moisture in accordance with the application instructions supplied with the product. The finish rating when Fiber Sprayed is used has not been determined. Alternate application method: The fiber is applied without water or adhesive in accordance with the application instructions supplied with a minimum density of 0.5 lb/ft³ over the resilient channel/gypsum board ceiling membrane when resilient channels and gypsum board attachment is modified as specified in Items 6 and 7. Alternate application method: The fiber is applied without water or adhesive to a nominal density of 3.5 lb/ft³ behind netting (Item 11) stapled to the rafters. The netting is stapled at both lower edges of the rafters creating a cavity to accept the cellulose fiber. The finished rating when this insulation is used has not been determined.

When Type AG-C panels are installed there is no limit on maximum thickness.

When Type TG-C panels are installed the maximum thickness is 3-1/2 in.

APPLEGATE GREENFIBER ACQUISITION LLC — INS735, INS745, INS750LD, Insulmax, and SANCTUARY for use with wet or dry application. INS510LD, INS515LD, INS541LD, INS735, INS765LD, and INS773LD are to be used for dry application only.

3C. Foamed Plastic* — For Use With American Gypsum Type AG-C only. (As an alternate to Item 3, Not Shown) — Spray foam insulation applied directly to the underside of the underside of the roofing system (Item 1). Spray foam insulation installed to a maximum thickness of 10 in. at a nominal 0.5 lb/ft³ density, while maintaining a minimum 8-1/2 in. clearance between the spray foam insulation and the gypsum board. When spray foam insulation is used, resilient channels (Item 6) shall be installed maximum 12 in. OC, with channels adjacent to butt joints of gypsum board (Item 7) installed at 6 in. OC to allow for maximum 3 in. spacing off ends of the gypsum board joints. Gypsum board to be installed using 1-1/4 in. long Type S screws, spaced maximum 8 in. OC, and butted end joints shall be staggered min. 2 ft within the assembly, and occur midway between the continuous furring channels. If used with a ceiling damper (Items 5 through 5AC) in the concealed space, minimum 1 in. clearance to be maintained between damper housing and spray foam insulation. Limited to resilient channels, Item 6 only, no Item 6 alternates. The finished rating when this insulation is used has not been determined.

SES FOAM INC — Sucraseal

3D. Foamed Plastic* — For Use With American Gypsum Type AG-C only. (As alternate to Item 3 Not Shown) — Spray foam insulation applied directly to the underside of the roofing system. Spray foam insulation installed to a maximum thickness of 10 in. at a nominal 0.5 lb/ft³ or 2.0 lb/ft³ density, depending on the product installed. When spray foam insulation is installed, resilient channels (Item 6) shall be installed maximum 12 in. OC, with channels adjacent to butt joints of gypsum board spaced maximum 3 in. away from gypsum butt joints. Gypsum board to be installed using minimum

1-1/4 in. long Type S screws, spaced maximum 8 in. OC, and butted end joints shall be staggered min. 2 ft within the assembly, and occur midway between the continuous furring channels. If used with a ceiling damper (Items 5 through 5AC) in the concealed space, minimum 1 in. clearance to be maintained between damper housing and spray foam insulation. Limited to resilient channels, Item 6 only, no Item 6 alternates.. The finished rating when this insulation is used has not been determined.
BASF CORP — Enertite® NM, Enertite® G, FE178®, Spraytite® 178, Spraytite® 81206, Walltite® 200, Walltite® US, Walltite® US-N, and Walltite® HP+

3E. Foamed Plastic* — For Use With American Gypsum Type AG-C only. (As an alternate to Item 3, Not Shown) — Spray foam insulation applied directly to the underside of the underside of the roofing system. Spray foam insulation installed to a maximum thickness of 17 in. at a nominal 0.5 lb/ft³ density, while maintaining a minimum 1-1/2 in. clearance between the spray foam insulation and the gypsum board. When spray foam insulation is used, resilient channels (Item 6) shall be installed maximum 12 in. OC, with channels adjacent to butt joints of gypsum board installed at 6 in. OC to allow for maximum 3 in. spacing off ends of the gypsum board joints. Gypsum board to be installed using 1-1/4 in. long Type S screws, spaced maximum 8 in. OC, and butted end joints shall be staggered min. 2 ft within the assembly, and occur midway between the continuous furring channels. If used with a ceiling damper (Items 5 through 5AC) in the concealed space, no clearance is necessary between damper housing and spray foam insulation. Limited to resilient channels, Item 6 only, no Item 6 alternates. The finished rating when this insulation is used has not been determined.
SES FOAM INC — EasySeal.5

3F. Foamed Plastic* — (As alternate to Item 3 - not to be used in combination with any alternates to item 3) — Spray foam insulation applied directly to the underside of the underside of the roofing system. Spray foam insulation installed to a maximum thickness of 11 in. at a nominal 1.0 lb/ft³ - 2.5 lb/ft³ density, while maintaining a minimum 7 in. clearance between the spray foam insulation and the gypsum board (Item 7). Spray foam insulation is limited for use with minimum 18 in. deep trusses (Item 2). When spray foam insulation is installed, resilient channels (Item 6) shall be installed maximum 12 in. OC, with channels adjacent to butt joints of gypsum board spaced maximum 3 in. away from gypsum butt joints. Gypsum board to be installed using minimum 1-1/4 in. long Type S screws, spaced maximum 8 in. OC, and butted end joints shall be staggered min. 2 ft within the assembly, and occur midway between the continuous furring channels, as illustrated above. If used with a ceiling damper (Items 5 through 5AC) in the concealed space, no clearance is necessary between damper housing and spray foam insulation. Only for use with item 5 not evaluated for use with alternates to item 5. Only for use with item 6 not evaluated for use with alternates to item 6.
CARLISLE SPRAY FOAM INSULATION — Types SealTite Pro Closed Cell (CC), SealTite Pro Open Cell (OC), SealTite Pro OCX, SealTite Pro No Trim 21, SealTite Pro One Zero, SealTite PRO HFO, Foamsulate Closed Cell, Foamsulate OCX, Foamsulate 70, Foamsulate HFO, and Foamsulate HFO 2.0.

4. Air Duct* — For use with **Ceiling Damper*** - Any UL Class 0 or Class 1 flexible air duct installed in accordance with the instructions provided by the damper manufacturer.

5. Ceiling Damper* — Nom 20 in. long by 18 in. wide by 2-1/8 in. high, fabricated from galvanized steel. Plenum box maximum size nom. 21 in. long by 18 in. wide by 16 in. high fabricated from either galvanized steel or Classified Air Duct Materials bearing the UL Class 0 or Class 1 rigid air duct material. Installed in accordance with the instructions provided by the manufacturer. Max damper openings not to exceed 180 sq in. per 100 sq ft of ceiling area.

NAILOR INDUSTRIES INC — Types 0755, 0755A, 0756, 0756D, 0757, 0757D, 0757FP, 0757DFP, 0758, 0759, 0760, 0761, 0762, 0763, CRD5, CRD5D, CRD6, CRD6D, CRD6FP, CRD6DFP.

SAFE AIR DOWCO — 0455, 0455A, 0456, 0456D, 0457, 0457D, 0457-DB, 0457-CB, 0463-FB, 0457-EB, 0463-GB, 0463

5A. **Alternate Ceiling Damper*** — Max plenum box size nom 19 in. long by 19 in. wide and 11-7/8 in. high fabricated from galv steel. Aggregate damper openings shall not exceed 128 sq in. per 100 sq ft of ceiling area. Damper installed in accordance with the manufacturers installation instructions provided with the damper.

AIRE TECHNOLOGIES INC — Models: CRD model 50 w/Boot, CRD model 50EA w/Boot, CRD model 55 w/Boot, CRD model 55 EA w/Boot

LLOYD INDUSTRIES INC — Model CRD 50-BT, CRD 50-EA-BT, CRD 55-BT, CRD 55 EA-BT

5B. **Alternate Ceiling Damper*** — Max plenum box size nom 13 in. long by 13 in. wide and 11-7/8 in. high fabricated from galv steel. Aggregate damper openings shall not exceed 50 sq in. per 100 sq ft of ceiling area. Damper installed in accordance with the manufacturers installation instructions provided with the damper.

LLOYD INDUSTRIES INC — Model CRD 50-BT-6, CRD 50-EA-BT-6, CRD 55-BT-6, CRD 55 EA-BT-6, CRD50-^w X-BT-6

5C. **Alternate Ceiling Damper*** — Max size ceiling outlet in plenum box nom 12 in. long by 12 in. wide. Plenum box fabricated from galv steel. Aggregate damper openings shall not exceed 72 sq in. per 100 sq ft of ceiling area. Installed in accordance with the manufacturers installation instructions provided with the damper.

AIRE TECHNOLOGIES INC — Models: CRD model 50 w/Boot, CRD model 50EA w/Boot, CRD model 55 w/Boot, CRD model 55 EA w/Boot

LLOYD INDUSTRIES INC — Model CRD 50-95BT, CRD 50-EA-95BT, CRD 55-95BT, CRD 55 EA-95BT

5D. **Alternate Ceiling Damper*** — Max size ceiling outlet in plenum box nom 16 in. long by 16 in. wide. Aggregate damper openings shall not exceed 128 sq in. per 100 sq ft of ceiling area. Damper installed in accordance with the manufacturers installation instructions provided with the damper.

LLOYD INDUSTRIES INC — Models CRD 50- FGPB-4.2, - 4.2 NI, -6.0, -6.0 NI; CRD50-EA-FGPB-4.2, - 4.2 NI, -6.0, -6.0 NI

5E. **Alternate Ceiling Damper*** — Max plenum box size nom 15 in. long by 15 in. wide and 11-7/8 in. high fabricated from galv steel. Aggregate damper openings shall not exceed 72 sq in. per 100 sq ft of ceiling area. Damper installed in accordance with the manufacturers installation instructions provided with the damper.

LLOYD INDUSTRIES INC — Models 45-CRD-LT-BT and 45-CRD-LTD-BT

5F. **Alternate Ceiling Damper*** — Max size ceiling outlet in plenum box nom 10 in. long by 10 in. wide. Plenum box fabricated from galv steel. Aggregate damper openings shall not exceed 50 sq in. per 100 sq ft of ceiling area. Installed in accordance with the manufacturers installation instructions provided with the damper.

LLOYD INDUSTRIES INC — Model 45-LTD-95-BT-4

5G. **Alternate Ceiling Damper*** — Max plenum box size nom 19 in. long by 15 in. wide and 11-7/8 in. high fabricated from galv steel. Aggregate damper openings shall not exceed 96 sq in. per 100 sq ft of ceiling area. Damper installed in accordance with the manufacturers installation instructions provided with the damper.

LLOYD INDUSTRIES INC — Model CRD50-^w X-BT

5H. **Alternate Ceiling Damper*** — Max nom area shall be 324 sq in. Max square size shall be 18 in. by 18 in. Rectangular sizes not to exceed 324 sq in. with a max width of 18 in. Max height of damper shall be 14 in. Aggregate damper openings shall not exceed 162 sq in. per 100 sq ft of ceiling area. Damper installed in accordance with the manufacturers installation instructions provided with the damper. A steel grille (Item 9) shall be installed in accordance with installation instructions.

C&S AIR PRODUCTS — Model RD-521

POTTORFF — Model CFD-521

5I. **Alternate Ceiling Damper*** — Max nom area shall be 196 sq in. Max square size shall be 14 in. by 14 in. Rectangular sizes not to exceed 196 sq in. with a max width of 26 in. Max height of damper shall be 7 in. Aggregate damper openings shall not exceed 98 sq in. per 100 sq ft of ceiling area. Damper installed in accordance with the manufacturers installation instructions provided with the damper. A steel grille (Item 9) not to exceed 144 in.2 shall be installed in accordance with installation instructions.

C&S AIR PRODUCTS — Model RD-521-BT

POTTORFF — Model CFD-521-BT

5J. **Alternate Ceiling Damper*** — Max nom area shall be 256 sq in. with the length not to exceed 24 in. and the width not to exceed 20 in. Max height of damper shall be 17 in. Aggregate damper openings shall not exceed 128 sq in. per 100 sq ft of ceiling area. Damper installed in accordance with the manufacturers installation instructions provided with the damper. A steel grille (Item 9) shall be installed in accordance with installation instructions.

C&S AIR PRODUCTS — Model RD-521-IP, RD-521-NP

POTTORFF — Models CFD-521-IP, CFD-521-NP

5K. **Alternate Ceiling Damper*** — Max nom area shall be 144 sq in. with the length not to exceed 14 in. and the width not to exceed 12 in. Max height of damper shall be 17-7/8 in. Aggregate damper openings shall not exceed 74 sq in. per 100 sq ft of ceiling area. Damper installed in

accordance with the manufacturers installation instructions provided with the damper. A steel grille (Item 9) shall be installed in accordance with installation instructions.

C&S AIR PRODUCTS — Model RD-521-90, RD-521-NP90

POTTORFF — Models CFD-521-90, CFD-521-90NP

5L. **Alternate Ceiling Damper*** — (Optional) Max nom area shall be 324 sq in. Max square size shall be 18 in. by 18 in. Rectangular sizes not to exceed 324 sq in. with a max width and max length of 18 in. Max round size shall be 18 in. dia. Aggregate damper openings shall not exceed 162 sq in. per 100 sq ft of ceiling area. Damper installed in accordance with the manufacturers installation instructions provided with the damper.

RUSKIN COMPANY — Models CFD7T, CFD7T-END-BT, CFD7T-90-BT, CFD7T-ST-BT, CFD7T-SB, CFD7T-R6-DB, CFD7T-IB6, or CFDR7T

5M. **Alternate Ceiling Damper*** — Ceiling damper & fan assembly. Max nom area shall be 75 sq in. with the length not to exceed 8-9/16 in. and the width not to exceed 8-3/4 in. Max height of damper shall be 9-7/8 in. Aggregate damper openings shall not exceed 38 sq in. per 100 sq ft of ceiling area. Damper shall be installed in combination with one of the fan models described in, and in accordance with, the manufacturers installation instructions provided with the damper. A plastic grille shall be installed in accordance with installation instructions.

DELTA ELECTRONICS INC — Models CRD2, GBR-CRD, ITG-CRD

5N. **Alternate Ceiling Damper*** — Max nom area shall be 324 sq in. Max square size shall be 18 in. by 18 in. Rectangular sizes not to exceed 324 sq in. with a max length of 20 in. and a max width of 22 in. Max height of damper shall be 14 in. Aggregate damper openings shall not exceed 154 sq in. per 100 sq ft of ceiling area. Damper installed in accordance with the manufacturer's installation instructions provided with the damper. An aluminum or steel grille shall be installed in accordance with installation instructions.

UNITED ENERTECH CORP — Type C-S/R-WT or C-S/R-WTP (Max nom area 324 sq. in.) or C-S/R-WTS or C-S/R-WTPS (Max nom area 162 sq. in.)

5O. **Alternate Ceiling Damper*** — Ceiling damper & fan assembly. Max nom area shall be 75 sq in. with the length not to exceed 9-1/4 in. and the width not to exceed 9-3/4 in. Max height of damper shall be 9-7/8 in. Aggregate damper openings shall not exceed 45 sq in. per 100 sq ft of ceiling area. Damper shall be installed in combination with one of the fan models described in, and in accordance with, the manufacturer's installation instructions provided with the damper. A plastic grille shall be installed in accordance with installation instructions.

DELTA ELECTRONICS INC — Model SIG-CRD

5P. **Alternate Ceiling Damper*** — Ceiling damper & fan assembly. Max nom area shall be 131 sq in. with the length not to exceed 11-1/16 in. and the width not to exceed 11-7/8 in. Aggregate damper openings shall not exceed 66 sq in. per 100 sq ft of ceiling area. Damper shall be installed in combination with one of the fan models described in, and in accordance with, the manufacturer's installation instructions provided with the damper. A plastic grille (Item 9) shall be installed in accordance with installation instructions.

DELTA ELECTRONICS INC — Model SMT-CRD

5Q. **Alternate Ceiling Damper*** — Ceiling damper & fan assembly. Max nom area shall be 103 sq in. with the length not to exceed 10-1/8 in. and the width not to exceed 10-1/8 in. Aggregate damper openings shall not exceed 52 sq in. per 100 sq ft of ceiling area. Damper shall be installed in combination with one of the fan models described in, and in accordance with, the manufacturer's installation instructions provided with the damper. A plastic grille shall be installed in accordance with installation instructions.

PANASONIC CORPORATION, PANASONIC CORPORATION OF NORTH AMERICA — Model PC-RD05C5

5R. **Alternate Ceiling Damper*** — Ceiling damper & fan assembly. Max nom area shall be 113 sq in. with the length not to exceed 10-1/8 in. and the width not to exceed 11-1/8 in. Aggregate damper openings shall not exceed 57 sq in. per 100 sq ft of ceiling area. Damper shall be installed in combination with one of the fan models described in, and in accordance with, the manufacturer's installation instructions provided with the damper. A plastic grille shall be installed in accordance with installation instructions.

BROAN-NUTONE L L C — Model RDFUWT

5S. **Alternate Ceiling Damper*** — Ceiling damper & fan assembly. Max nom area shall be 79 sq in. with the length not to exceed 10 in. and the width not to exceed 7-15/16 in. Aggregate damper openings shall not exceed 40 sq in. per 100 sq ft of ceiling area. Damper shall be installed in combination with one of the fan models described in, and in accordance with, the manufacturer's installation instructions provided with the damper. A metallic grille shall be installed in accordance with installation instructions.

BROAN-NUTONE L L C — Models RDJ1 and RDH

5T. **Alternate Ceiling Damper*** — Max plenum box size nom 19 in. long by 19 in. wide and 11-7/8 in. high fabricated from galv steel. Aggregate damper openings shall not exceed 128 sq in. per 100 sq ft of ceiling area. Damper installed in accordance with the manufacturers installation instructions provided with the damper.

METAL-FAB INC — Models MSCD-HC and MRCD-HC

5U. **Alternate Ceiling Damper*** — Ceiling damper & fan assembly. Max nom area shall be 87 sq in. with the length not to exceed 9 in. and the width not to exceed 9-11/16 in. Aggregate damper openings shall not exceed 44 sq in. per 100 sq ft of ceiling area. Damper shall be installed in combination with one of the fan models described in, and in accordance with, the manufacturer's installation instructions provided with the damper. A plastic grille shall be installed in accordance with installation instructions.

BROAN-NUTONE L L C — Model RDMWT

5V. **Alternate Ceiling Damper*** — Ceiling damper & fan assembly. Max nom area shall be 87 sq in. with the length not to exceed 9 in. and the width not to exceed 9-11/16 in. Aggregate damper openings shall not exceed 44 sq in. per 100 sq ft of ceiling area. Damper shall be installed in combination with one of the fan models described in, and in accordance with, the manufacturer's installation instructions provided with the damper. A plastic grille shall be installed in accordance with installation instructions.

BROAN-NUTONE L L C — Model RDMWT2

5W. **Alternate Ceiling Damper*** — Max nom 21 in. long by 18 in. wide, fabricated from galvanized steel. Plenum box max size nom 21 in. long by 18 in. wide by 14 in. high (inner dimension) fabricated from either galvanized steel or min 1 in. thick Listed Duct Board bearing the UL Listing Marking having a min R-Value of 4.3. Installed in accordance with the instructions provided by the manufacturer. Max damper openings not to exceed 180 sq in. per 100 sq ft of ceiling area.
GREENHECK FAN CORP — Model CRD-1WT

5X. **Alternate Ceiling Damper*** — Max nom 12 in. long by 12 in. wide with an 8 in. diameter damper, fabricated from galvanized steel. Installed in accordance with the instructions provided by the manufacturer. Max damper openings not to exceed 72 sq in. per 100 sq ft of ceiling area.
GREENHECK FAN CORP — Model CRD-2WT

5Y. **Alternate Ceiling Damper*** — Max 12 in. diameter damper and insulated register box assembly. The maximum size of the register box assembly is nom. 20 in. long by 20 in. wide and 4 in. high fabricated from galv steel. The aggregate area of the register opening(s) through the ceiling membrane shall not exceed 128 sq in. per 100 sq ft of ceiling area. Damper assembly installed in accordance with the manufacturers installation instructions.
AIRE TECHNOLOGIES INC — Model 57IB.

5Z. **Alternate Ceiling Damper*** — Max 20 in. long by 16 in. wide by 4 in. high rectangular damper with plenum box assembly. The maximum outer dimensions of the plenum box assembly is 23-1/2 in. long by 19-1/2 in. wide and 17 in. high fabricated from 6pcf, 1-1/2 to 2 in. thick Knauf Air Duct Board M*. The aggregate area of the register opening(s) through the ceiling membrane shall not exceed 160 sq in. per 100 sq ft ceiling area. Damper assembly installed in accordance with the manufacturers installation instructions.
AIRE TECHNOLOGIES INC — Series 58.

5AA. **Alternate Ceiling Damper*** — Max 14 in. long by 14 in. wide and 18 in. high ceiling damper with boot or box assembly, fabricated from galv steel. The aggregate area of the register opening(s) through the ceiling membrane shall not exceed 98 sq in. per 100 sq ft of ceiling area. Damper assembly installed in accordance with the manufacturers installation instructions.
AIRE TECHNOLOGIES INC — Model 51 w/Boot.

5AB. **Alternate Ceiling Damper*** — Max nom 11-1/8 in. long by 13-5/8 in. wide, fabricated from galvanized steel. Installed in accordance with the instructions provided by the manufacturer. Max damper openings not to exceed 76 sq in. per 100 sq ft of ceiling area.
GREENHECK FAN CORP — Model CRD-310WT

5AC. **Alternate Ceiling Damper*** — Max nom 12-3/8 in. long by 14-1/2 in. wide, fabricated from galvanized steel. Installed in accordance with the instructions provided by the manufacturer. Max damper openings not to exceed 90 sq in. per 100 sq ft of ceiling area.
GREENHECK FAN CORP — Model CRD-320WT

5AD. **Alternate Ceiling Damper*** — Max 12 in. diameter damper within max 15 in. by 15 in. register box with max 12 in. by 12 in. register opening fabricated from galvanized steel. Aggregate area of the register opening(s) through the ceiling membrane shall not exceed 72 sq. in. per 100 sq. ft. of ceiling area. Damper assembly installed in accordance with the manufacturer's installation instructions.

RUSKIN COMPANY — Model CFD7T-SR

5AE. **Alternate Ceiling Damper*** — Max 12 in. diameter damper and insulated register box assembly. The maximum size of the register box assembly is nom. 20 in. long by 20 in. wide and 4 in. high fabricated from galv steel. The aggregate area of the register opening(s) through the ceiling membrane shall not exceed 128 sq in. per 100 sq ft of ceiling area. Damper assembly installed in accordance with the manufacturers installation instructions.

SOUTHWARK METAL MFG CO — Model 800 w/Box

5AF. **Alternate Ceiling Damper*** — Max 20 in. long by 16 in. wide by 4 in. high rectangular damper with plenum box assembly. The maximum outer dimensions of the plenum box assembly are 23-1/2 in. long by 19-1/2 in. wide and 17 in. high fabricated from 6pcf, 1-1/2 to 2 in. thick Knauf Air Duct Board M*. The aggregate area of the register opening(s) through the ceiling membrane shall not exceed 160 sq in. per 100 sq ft ceiling area. Damper assembly installed in accordance with the manufacturers installation instructions.

SOUTHWARK METAL MFG CO — CRD w/DB Box

5AG. **Alternate Ceiling Damper*** — Max 14 in. long by 14 in. wide and 18 in. high ceiling damper with boot or box assembly, fabricated from galv steel. The aggregate area of the register opening(s) through the ceiling membrane shall not exceed 98 sq in. per 100 sq ft of ceiling area. Damper assembly installed in accordance with the manufacturers installation instructions.

SOUTHWARK METAL MFG CO — Model 500 w/Boot, 510 w/Boot, 500 w/Box or 510 w/Box

5AH. **Alternate Ceiling Damper*** — Max nom 10-3/8 in. long by 10-3/8 in. wide, fabricated from galvanized steel. Installed in accordance with the instructions provided by the manufacturer. Max damper openings not to exceed 54 sq in. per 100 sq ft of ceiling area.

GREENHECK FAN CORP — Model CRD-300WT

6. **Furring Channels** — Resilient channels formed of 25 MSG galv steel, spaced 16 in. OC, installed perpendicular to trusses. When insulations are installed or draped over the resilient channel/gypsum wallboard ceiling membrane, the spacing shall be as described below. Channels secured to each truss with 1-1/4 in. long Type S steel screws. Channels overlapped 4 in. at splices. Channels oriented opposite at wallboard butt joints (spaced 6 in. OC) as shown in the above illustration.

When Type AG-C panels are attached to the resilient channels, the channels may remain at 16 in. OC.

When Type TG-C panels are attached to the resilient channels, the channels are installed at 12 in. OC.

6A. **Steel Framing Members*** — (Not Shown) — As an alternate to Item 6, furring channels and Steel Framing Members* as described below:

a. **Furring Channels** — Formed of No. 25 MSG galv steel, 2-9/16 in. or 2-23/32 in. wide by 7/8 in. deep, spaced 16 in. OC perpendicular to trusses. When batt insulation (Item 3) is draped over the resilient channel/gypsum board ceiling membrane, the resilient channel spacing shall be reduced to 12 in. OC. Channels secured to trusses as described in Item b. Ends of adjoining channels overlapped 6 in. and tied together with double strand of No. 18 SWG galv steel wire near each end of overlap.

b. **Steel Framing Members*** — Used to attach furring channels (Item a) to trusses (Item 2). Clips spaced 48 in. OC. RSIC-1 and RSIC-1 (2.75) clips secured to alternating trusses with No. 8 x 2-1/2 in. coarse drywall screw through the center grommet. RSIC-V and RSIC-V (2.75) clips secured to alternating trusses with No. 8 x 1-1/2 in. coarse drywall screw through the center hole. Furring channels are friction fitted into clips. RSIC-1 and RSIC-V clips for use with 2-9/16 in. wide furring

channels. RSIC-1 (2.75) and RSIC-V (2.75) clips for use with 2-23/32 in. wide furring channels. Adjoining channels are overlapped as described in Item a. As an alternate, ends of adjoining channels may be overlapped 6 in. and secured together with two self-tapping No. 6 framing screws, min 7/16 in. long at the midpoint of the overlap, with one screw on each flange of the channel. Additional clips required to hold furring channel that supports the gypsum board butt joints, as described in Item 7.

PAC INTERNATIONAL L L C — Types RSIC-1, RSIC-V, RSIC-1 (2.75), RSIC-V (2.75)

6B. Alternate Steel Framing Members* — (Not Shown) — Not evaluated with Item 3 (Batts and Blankets). As an alternate to Items 6 or 6A, furring channels and Steel Framing Members as described below.

a. **Furring Channels** — Formed of No. 25 MSG galv steel, 2-5/8 in. wide by 7/8 in deep, spaced 16 in OC, perpendicular to trusses. Channels secured to trusses as described in Item b.

b. **Steel Framing Members*** — Used to attach furring channels (Item a) to the wood trusses (Item 2). Clips spaced at 48" OC and secured to the bottom of the trusses with one 2 in. Coarse Drywall Screw with 1 in. diam washer through the center hole. Furring channels are then friction fitted into clips. Ends of channels are overlapped 6" and tied together with double strand of No. 18 AWG galvanized steel wire. Additional clips are required to hold the Gypsum Butt joints as described in Item 7.

STUDCO BUILDING SYSTEMS — RESILMOUNT Sound Isolation Clips - Type A237 or A237R

6C. Alternate Steel Framing Members* — (Not Shown) — Not evaluated with Item 3 (Batts and Blankets). As an alternate to Items 6 through 6B, furring channels and Steel Framing Members as described below.

a. **Furring Channels** — Formed of No. 25 MSG galv steel, 2-1/2 in. wide by 7/8 in deep, spaced 16 in OC, perpendicular to trusses. Channels secured to trusses as described in Item b.

b. **Steel Framing Members*** — Used to attach furring channels (Item a) to the wood trusses (Item 2). Clips spaced at 48" OC and secured to the bottom of the trusses with one 2-1/2 in. Coarse Drywall Screw with 1 in. diam washer through the center hole. Furring channels are then friction fitted into clips. Ends of channels are overlapped 6" and tied together with double strand of No. 18 AWG galvanized steel wire. Additional clips are required to hold the Gypsum Butt joints as described in Item 7.

REGUPOL AMERICA — Type SonusClip

7. Gypsum Board* — Nom 5/8 in. thick, 48 in. wide, installed with long dimension perpendicular to resilient channels with 1 in. long Type S screws spaced 12 in. OC and located a min of 1/2 in. from side joints and 3 in. from the end joints. At end joints, two resilient channels are used, extending a min of 6 in. beyond both ends of the joint. When batt and blanket insulation, Item 3, is draped over the resilient channel/gypsum wallboard ceiling membrane, screws shall be installed at 8 in. OC. When **Steel Framing Members** (Item 6B) are used, one layer of nom 5/8 in. thick, 4 ft wide gypsum board is installed with long dimensions perpendicular to furring channels. Gypsum board secured to furring channels with nom 1 in. long Type S bugle-head steel screws spaced 8 in. OC in the field of the board. Gypsum board butted end joints shall be staggered minimum 48 in. and centered over main furring channels. At the gypsum board butt joints, each end of each gypsum board shall be supported by a single length of furring channel equal to the width of the gypsum board plus 3 in. on each end. The two support furring channels shall be spaced approximately 3 in. in from end joint. Screw spacing along the gypsum board butt joint and along both additional channels shall be 8 in.

OC. Additional screws shall be placed in the adjacent section of gypsum board into the aforementioned 3 in. extension of the extra butt joint channels as well as into the main channel that runs between. Butt joint furring channels shall be attached with one RESILMOUNT Sound Isolation Clip at each end of the channel.

When **Steel Framing Members** (Item 6C) are used, one layer of nom 5/8 in. thick, 4 ft wide gypsum board is installed with long dimensions perpendicular to furring channels. Gypsum board secured to furring channels with nom 1 in. long Type S bugle-head steel screws spaced 8 in. OC in the field of the board. Gypsum board butted end joints shall be staggered minimum 48 in. and centered over main furring channels. At the gypsum board butt joints, an additional single length of furring channel shall be installed and be spaced approximately 3 in. from the butt joint (6 in. from the continuous furring channels) to support the floating end of the gypsum board. Each of these shorter sections of furring channel shall extend one truss beyond the width of the gypsum panel and be attached to the adjacent trusses with one SonusClip at every truss involved with the butt joint.

AMERICAN GYPSUM CO — Types AG-C

GEORGIA-PACIFIC GYPSUM L L C — Type TG-C

7A. **Gypsum Board*** — (As an alternative to Item 7) — For use when no insulation is used. Nom 5/8 in. thick, 48 in. wide gypsum board, installed as described in item 7 with resilient channels (Item 6) spaced 24 in OC.

AMERICAN GYPSUM CO — Type AG-C

8. **Finishing System** — (Not Shown) — Vinyl, dry or premixed joint compound, applied in two coats to joints and screw-heads; paper tape, 2 in. wide, embedded in first layer of compound over all joints. As an alternate, nom 3/32 in. thick veneer plaster may be applied to the entire surface of gypsum wallboard.

9. **Grille** — Installed in accordance with the installation instructions provided with the ceiling damper

10. **Discrete Products Installed in Air-handling Spaces*** — Automatic Balancing Valve/Damper — (Not Shown - Optional) — For use with item 5L, Ruskin Company's Model CFD7T damper (CABS). Ceiling damper to be provided with plenum box per damper manufacturer's instructions with side outlet only. Entire assembly to be installed into any UL Class 0 or Class 1 flexible air duct in accordance with the instructions provided by the automatic balancing valve/damper manufacturer.

METAL INDUSTRIES INC — Model ABV-4, ABV-5, ABV-6

11. **Netting** — (Not shown) Fibrous, woven netting material fastened to underside of each joist with staples, with side joints overlapped.

12. **Netting** — (Not shown) - Non-woven polypropylene fabric fastened to underside of each joist with staples, with side joints overlapped. For use with Type AG-C gypsum boards only.

*** Indicates such products shall bear the UL or cUL Certification Mark for jurisdictions employing the UL or cUL Certification (such as Canada), respectively.**

Last Updated on 2023-02-15

