

Design No. M549

July 21, 2020

Unrestrained Assembly Rating - 1 Hr.

Finish Rating - 26 Min.

This design was evaluated using a load design method other than the Limit States Design Method (e.g., Working Stress Design Method). For jurisdictions employing the Limit States Design Method, such as Canada, a load restriction factor shall be used — See Guide [BXUV](#) or [BXUV7](#)

** Indicates such products shall bear the UL or cUL Certification Mark for jurisdictions employing the UL or cUL Certification (such as Canada), respectively.*

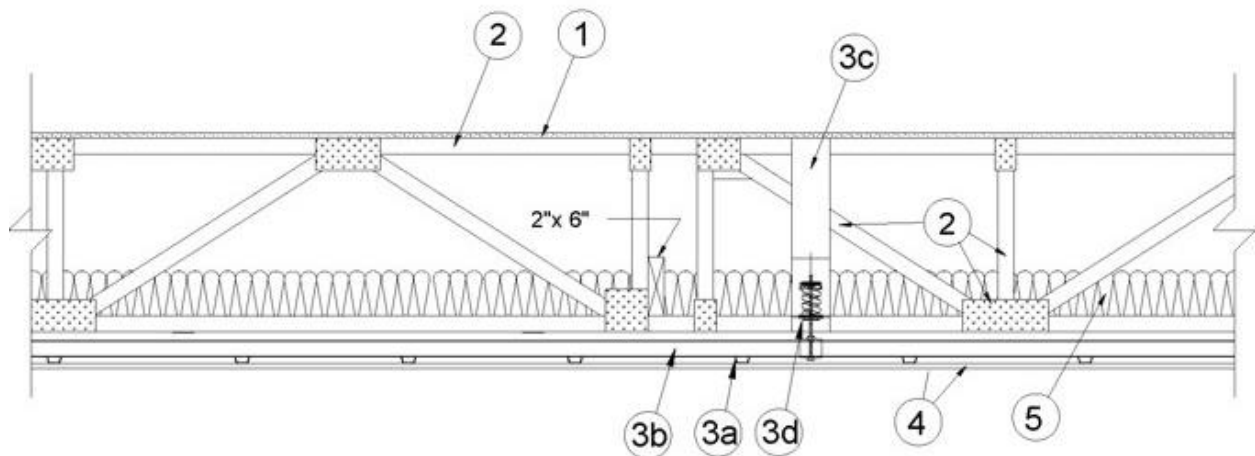

1. **Flooring System** — The flooring system shall consist of one of the following:

System No. 1

Subflooring — Nom 23/32 in. thick wood structural panels installed perpendicular to trusses with end joints staggered. Plywood or panels secured to trusses with construction adhesive and No. 6d ringed shank nails, spaced 12 in. OC along each truss. Staples having equal or greater withdrawal and lateral resistance strength may be substituted for the 6d nails.

System No. 2

Subflooring — Nom 23/32 in. thick wood structural panels installed perpendicular to trusses with end joints staggered. Plywood or panels secured to trusses with construction adhesive and No. 6d ringed shank nails, spaced 12 in. OC along each truss. Staples having equal or greater withdrawal and lateral resistance strength may be substituted for the 6d nails.

Finish Floor — Min 1 by 4 in. T & G lumber, min 15/32 in. thick wood structural panels, or any UL Classified Floor Topping Mixture with or without UL Classified Floor Mat Material

2. **Trusses** — Parallel chord trusses, spaced a max 24 in. OC, fabricated from nom 2 by 4 in. lumber with lumber oriented vertically or horizontally. Min truss depth is 12 in. Truss members secured together with min No. 20 MSG galv steel truss plates. Plates have 5/16 in. long teeth projecting perpendicular to the plane of the plate. The teeth are in pairs facing each other (made by the same punch), forming a split-tooth-type plate. Each tooth has a chisel point on its outside edge. These points are diagonally opposite each other for each pair. The top half of each tooth has a twist for stiffness. The pairs are repeated on approx 7/8 in. centers with four rows of teeth per in. of plate width.

3. **Steel Framing Members*** —

a. **Furring Channels** — Formed of No. 25 MSG galv steel, nominal 2-1/2 in. wide by 7/8 in. deep, perpendicular to the trusses, spaced 12 in. OC when batts and blankets (Item 5) are draped over the furring channels, 16 in. OC when batts and blankets are suspended in the concealed space, or 24 in. OC when no insulation is used. Channels secured to Cold Rolled Channels at every intersection with a 3/4 in. TEK screw through each furring channel leg. Ends of adjoining channels overlapped 12 in. and fastened together with two double strand No. 18 SWG galv steel wire ties, one at each end of overlap, or with two 3/4 in. TEK screws in each leg of the overlap section. Two furring channels nominally 3 in. apart used at end joints of gypsum board (Item 4), each extending a min of 6 in. beyond both side edges of the board. Gypsum board attached to furring channels as described in Item 4.

b. **Cold Rolled Channels** — 1-1/2 in. by 1/2 in., formed from No. 16 ga. galv steel, positioned vertically and parallel to joists or trusses, friction-fitted into the channel caddy on the Steel Framing Members (Item 3d) and secured with two 3/4 in. TEK screws. Adjoining lengths of cold rolled channels lapped min. 12 in. and secured along bottom legs with four 3/4 in. TEK screws and wire-tied together with two double strand 18 SWG galv steel wire ties, one at each end of overlap.

c. **Blocking** — Where truss design does not permit direct, full contact of the hanger bracket, a piece of nominal 2 by 4 in. lumber (blocking), min. 12 in. long to permit full contact of the hanger bracket, to be secured vertically to the side of the trusses (Item 2) at the top and bottom of the blocking at each Steel Framing Member (Item 3d) location with 16d nails or minimum 2-1/2 in. screws.

d. **Steel Framing Members*** — Spaced 48 in. OC. max along truss, and secured to the truss or Blocking (Item 3c) on alternating trusses with two, #10 x 1-1/2 in. screws through mounting holes on the hanger bracket.

PAC INTERNATIONAL L L C — Type RSIC-SI-CRC EZ Clip

3A. **Steel Framing Members*** — (Optional, Not Shown) As an alternate to Item 3, furring channels and Steel Framing Members* as described below:

a. **Furring Channels** — Formed of No. 25 MSG galv steel, 2-9/16 in. wide by 7/8 in. deep, spaced as described in item 3a perpendicular to trusses. Channels secured to trusses as described in Item b. Ends of adjoining channels overlapped 6 in. and tied together with double strand of No. 18 SWG galv steel wire near each end of overlap.

b. **Steel Framing Members*** — Used to attach furring channels (Item a) to trusses (Item 2). Clips spaced 48 in. OC. RSIC-1 clips secured to alternating trusses with No. 8 x 2-1/2 in. coarse drywall screw through the center grommet. Furring channels are friction fitted into clips. RSIC-1 clips for use with 2-9/16 in. wide furring channels. Adjoining channels are overlapped as described in Item a. As an alternate, ends of adjoining channels may be overlapped 6 in. and secured together with two self-tapping No. 6 framing screws, min 7/16 in. long at the midpoint of the overlap, with one screw on each flange of the channel.

PAC INTERNATIONAL L L C — Type RSIC-1

4. **Gypsum Board*** — One layer of nom 5/8 in. thick, 4 ft wide gypsum board, installed with long dimension perpendicular to furring or resilient channels. Gypsum board secured with 1 in. long Type S bugle head steel screws spaced 8 in. OC. Adjacent butt joints staggered minimum 48 in. OC. End joints secured to both furring channels as shown in the end joint detail.

When **Steel Framing Members** (Item 3A) are used, gypsum panels installed with long dimensions perpendicular to furring channels. Panels attached to the furring channels using 1 in. long Type S bugle-head steel screws spaced 8 in. OC along butted end joints and in the field of the panel. Butted end joints shall be staggered min. 2 ft within the assembly, and occur midway between the continuous furring channels. Each end of each gypsum panel shall be supported by a single length of furring channel equal to the width of the gypsum panel plus 6 in. on each end. The two support furring channels shall be spaced approximately 3-1/2 in. OC, and be attached with one clip at each end of the channel.

PABCO BUILDING PRODUCTS L L C, DBA PABCO GYPSUM — Type C

5. **Batts and Blankets*** — Optional (Not Shown) — Nom 3-1/2 in. thick fiber glass or mineral wool insulation draped over the furring channels or held suspended in the concealed space with 0.090 in. diam galv steel wires attached to the wood trusses at 18 in. OC.

** Indicates such products shall bear the UL or cUL Certification Mark for jurisdictions employing the UL or cUL Certification (such as Canada), respectively.*

[Last Updated](#) on 2020-07-21