

Design/System/Construction/Assembly Usage Disclaimer

- Authorities Having Jurisdiction should be consulted in all cases as to the particular requirements covering the installation and use of UL Certified products, equipment, system, devices, and materials.
- Authorities Having Jurisdiction should be consulted before construction.
- Fire resistance assemblies and products are developed by the design submitter and have been investigated by UL for compliance with applicable requirements. The published information cannot always address every construction nuance encountered in the field.
- When field issues arise, it is recommended the first contact for assistance be the technical service staff provided by the product manufacturer noted for the design. Users of fire resistance assemblies are advised to consult the general Guide Information for each product category and each group of assemblies. The Guide Information includes specifics concerning alternate materials and alternate methods of construction.
- Only products which bear UL's Mark are considered Certified.

BXUV - Fire Resistance Ratings - ANSI/UL 263 Certified for United States

BXUV7 - Fire Resistance Ratings - CAN/ULC-S101 Certified for Canada

[See General Information for Fire-resistance Ratings - ANSI/UL 263 Certified for United States Design Criteria and Allowable Variances](#)

[See General Information for Fire Resistance Ratings - CAN/ULC-S101 Certified for Canada Design Criteria and Allowable Variances](#)

Design No. M523

March 3rd, 2025

Unrestrained Assembly Rating - 1 Hr.

This design was evaluated using a load design method other than the Limit States Design Method (e.g., Working Stress Design Method). For jurisdictions employing the Limit States Design Method, such as Canada, a load restriction factor shall be used — See Guide [BXUV](#) or [BXUV7](#)

*** Indicates such products shall bear the UL or cUL Certification Mark for jurisdictions employing the UL or cUL Certification (such as Canada), respectively.**

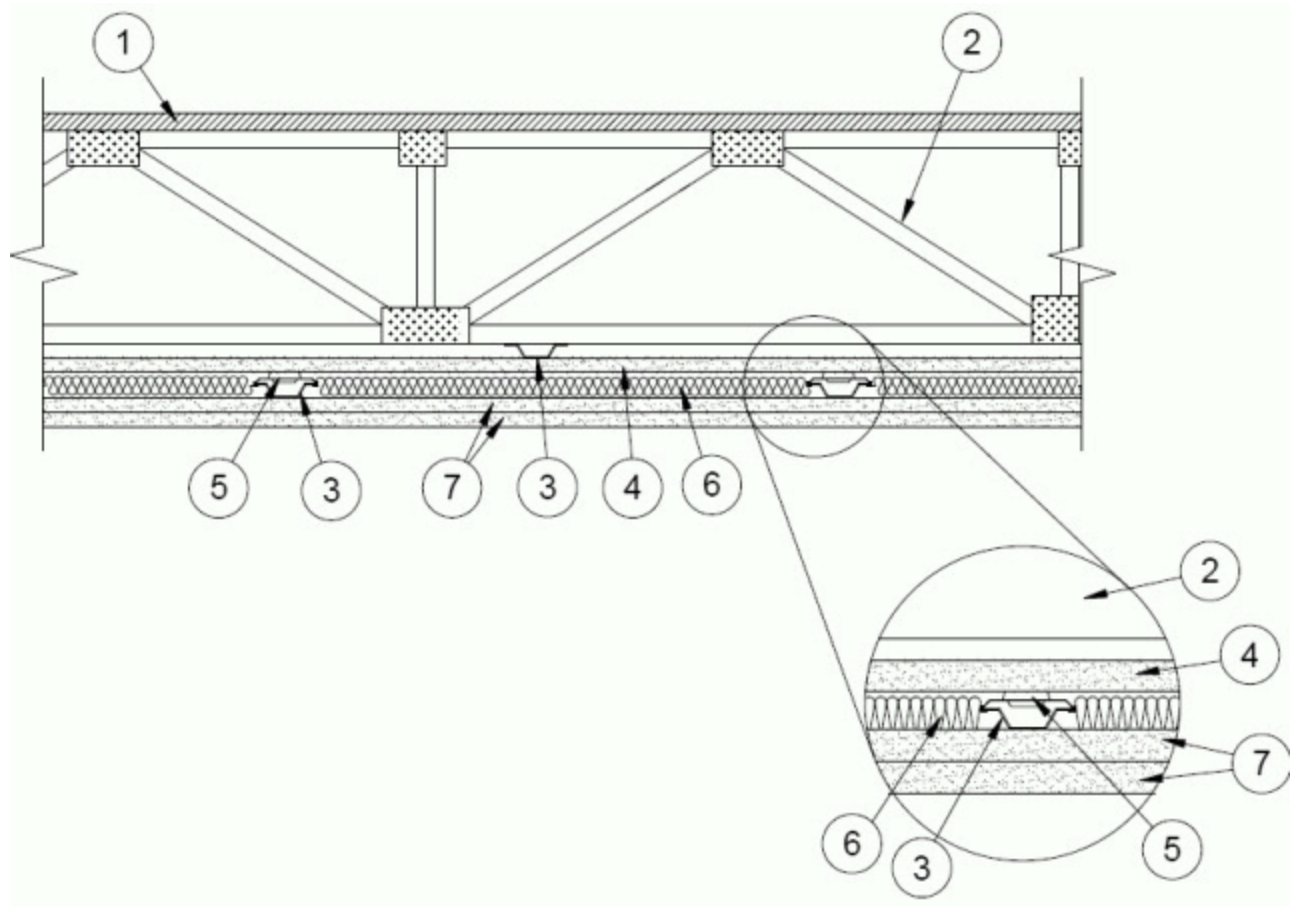

1. **Flooring System** — The flooring system shall consist of one of the following:

System No. 1

1. **Subflooring** — Min 23/32 in. thick T & G wood structural panels, min grade "Underlayment" or "Single-Floor". Face grain of plywood or strength axis of panels to be perpendicular to the trusses with end joints staggered 4 ft. Panels secured to trusses with construction adhesive and No. 6d ringed shank nails spaced 12 in. OC along each truss. Staples having equal or greater withdrawal and lateral resistance strength may be substituted for the 6d nails.
2. **Trusses** — Parallel chord trusses, spaced a max 24 in. OC, fabricated from nom 2 by 4 in. lumber with lumber oriented vertically or horizontally. Min truss depth is 12 in. Truss members secured together with min No. 20 MSG galv steel truss plates. Plates have 5/16 in. long teeth projecting perpendicular to the plane of the plate. The teeth are in pairs facing each other (made by the same punch), forming a split-tooth-type plate. Each tooth has a chisel point on its outside edge. These points are diagonally opposite each other for each pair. The top half of each tooth has a twist for stiffness. The pairs are repeated on approx 7/8 in. centers with four rows of teeth per in. of plate width.
3. **Furring Channels** — Furring channels, 7/8 in. deep by 2-9/16 in. or 2-11/16 in. or 2-23/32 in. wide at the base and 1-7/16 in. wide at the face, formed from No. 25 ga galv steel, spaced 24 in. OC perpendicular to trusses. Channels secured to trusses with double strand of No. 18 SWG galv steel wire spaced 48 in. OC. Ends of adjoining channels overlapped 6 in. and tied together with double strand of No. 18 SWG galv steel wire near each end of overlap. Two furring channels used at end joints of gypsum board (Item 5), each extending a min of 6 in. beyond both side edges of the board.
- 3A. **Resilient Channels** — (Not Shown) - As an alternate to Item 3, resilient channel formed from No. 26 MSG galv steel, spaced 16 in. OC perpendicular to trusses. Channels secured to each truss with 1-1/4 in. long No. 6 Type S bugle head steel screw. Channels overlapped at splices 4 in. Two resilient channels used at end joints of gypsum board), each extending a min of 6 in. beyond both side edges of the board.
4. **Gypsum Board*** — Nom 5/8 in. thick, 4 ft wide gypsum board, installed with long dimension perpendicular to furring or resilient channels. Gypsum board secured with 1 in. long No. 6 Type S bugle head steel screws spaced 12 in. OC and located a min of 1-1/2 in.

from side and end joints. End joints secured to both resilient channels. Perimeter may contain nominal 1/4 in. cuts. Cuts may be caulked with acoustic sealant. Gypsum may also contain nominal 3 in. diameter holes spaced 48 in. OC.

See Item 7 for names of manufacturers.

5. Steel Framing Members* — Clips spaced 48 in. OC. and attached through Gypsum Board (Item 4) to the bottom chord of alternating trusses with one No. 8 x 3-1/2 in. coarse drywall screw through the center hole. Furring channels (Item 3) are friction fitted into clips. Ends of adjoining channels overlapped 6 in. and tied together with double strand of No. 18 SWG galv steel wire near each end of overlap. Additional clips required to hold furring channel that supports the gypsum board butt joints, as described in Item 7.

Not for use with Item 3A.

PLITEQ INC — Type Genie Clip

5A. Steel Framing Members* — Clips spaced 48 in. OC. and attached through Gypsum Board (Item 4) to the bottom chords of trusses with one 2 in. coarse drywall screw with 1 in. diam washer through the center hole. Furring channels (Item 3) are friction fitted into clips. Ends of adjoining channels overlapped 6 in. and tied together with double strand of No. 18 SWG galv steel wire near each end of overlap. Additional clips required to hold furring channel that supports the gypsum board butt joints, as described in Item 7.

Not for use with Item 3A.

STUDCO BUILDING SYSTEMS — RESILMOUNT Sound Isolation Clips - Type A237R

5B. Steel Framing Members* — (Optional, Not Shown) — Used as an alternate method to attach resilient channels to structural members. A resilient sound isolation accessory shall be used at each attachment point of the resilient channels and spaced max 24 in. O.C. Channel ends butted and centered under the structural members and attached with one accessory at each end. Additional accessories used to hold resilient channels that support the gypsum board end joints. The accessory envelops the mounting edge of the resilient channel. The accessory and resilient channel are fastened to the structural members with the screws supplied with the accessory and per the accessory manufacturer's installation instructions. Gypsum Board butt joints staggered minimum 24 in. OC and base layer Gypsum Board screws spaced 8 in. OC (in lieu of 12 in.) when used.

PAC INTERNATIONAL L L C — Type RC-1 Boost

6. Batts and Blankets* — Nom 1-5/8 in. thick mineral wool insulation draped over furring channel (Item 3) between Gypsum Board above (Item 4) and Gypsum Board below (Item 7).

7. Gypsum Board* — First layer of nom 5/8 in. thick, 4 ft wide gypsum board is installed with long dimensions perpendicular to furring channels. Gypsum board secured to furring channels with nom 1 in. long No. 6 Type S bugle-head steel screws spaced 12 in. OC in the field of the board. Gypsum board butted end joints shall be staggered minimum 16 in. within the assembly. At the gypsum board butt joints, each end of each gypsum board shall be supported by a single length of furring channel equal to the width of the gypsum board plus 6 in. on each end. These additional furring channels shall be attached to underside of the truss with clips as described in Items 5 or 5A. Screw spacing along the gypsum board butt joint shall be 6 in. OC. Face layer boards secured to each furring channel through the base layer with 1-5/8 or 1-7/8 in. long Type S-12 bugle head steel screws, spaced a max of 8 in. OC. Screws located 1-1/2 to 2 in. and 5/8 to 3/4 in. from side and end joints, respectively. End joints and side joints of the face layer boards shall be staggered a min of 16 in. from the joints in the base layer. If end joints of the face layer boards are not centered on the furring channels, the end of boards at the end joint shall be attached to the base layer boards with 1-1/2 in. long Type G steel screws spaced 8 in. OC and located 1-1/2 in. from the end joint. All screws shall be driven no further than flush with the face of the boards in order not to damage the core of the boards.

AMERICAN GYPSUM CO — Type AG-C

CABOT MANUFACTURING ULC — 5/8 in. Type C

CERTAINTED GYPSUM INC — Type C

CGC INC — Types C, IP-X2, IPC-AR, ULIX

CERTAINTED GYPSUM INC — Type LGFC-C/A

GEORGIA-PACIFIC GYPSUM L L C — Types 5, DAPC, TG-C

NATIONAL GYPSUM CO — Types FSK-C, FSW-C, FSW-G

PABCO BUILDING PRODUCTS L L C, DBA PABCO GYPSUM — Type C

UNITED STATES GYPSUM CO — Types C, IP-X2, IPC-AR, ULIX

USG BORAL DRYWALL SFZ LLC — Type C

*** Indicates such products shall bear the UL or cUL Certification Mark for jurisdictions employing the UL or cUL Certification (such as Canada), respectively.**

Last Updated on 2025-03-03

The appearance of a company's name or product in this database does not in itself assure that products so identified have been manufactured under UL Solutions' Follow - Up Service. Only those products bearing the UL Mark should be considered to be Certified and covered under UL Solutions' Follow - Up Service. Always look for the Mark on the product.

UL Solutions permits the reproduction of the material contained in Product iQ subject to the following conditions: 1. The Guide Information, Assemblies, Constructions, Designs, Systems, and/or Certifications (files) must be presented in their entirety and in a non-misleading manner, without any manipulation of the data (or drawings). 2. The statement "Reprinted from Product iQ with permission from UL Solutions" must appear adjacent to the extracted material. In addition, the reprinted material must include a copyright notice in the following format: "©2025 UL LLC."