

Design No. **M521**

August 9, 2022

Unrestrained Assembly Rating - 2 Hr.

Finish Rating -- 91 or 98 Min. (See Item 6)

This design was evaluated using a load design method other than the Limit States Design Method (e.g., Working Stress Design Method). For jurisdictions employing the Limit States Design Method, such as Canada, a load restriction factor shall be used — See Guide [BXUV](#) or [BXUV7](#)

*** Indicates such products shall bear the UL or cUL Certification Mark for jurisdictions employing the UL or cUL Certification (such as Canada), respectively.**

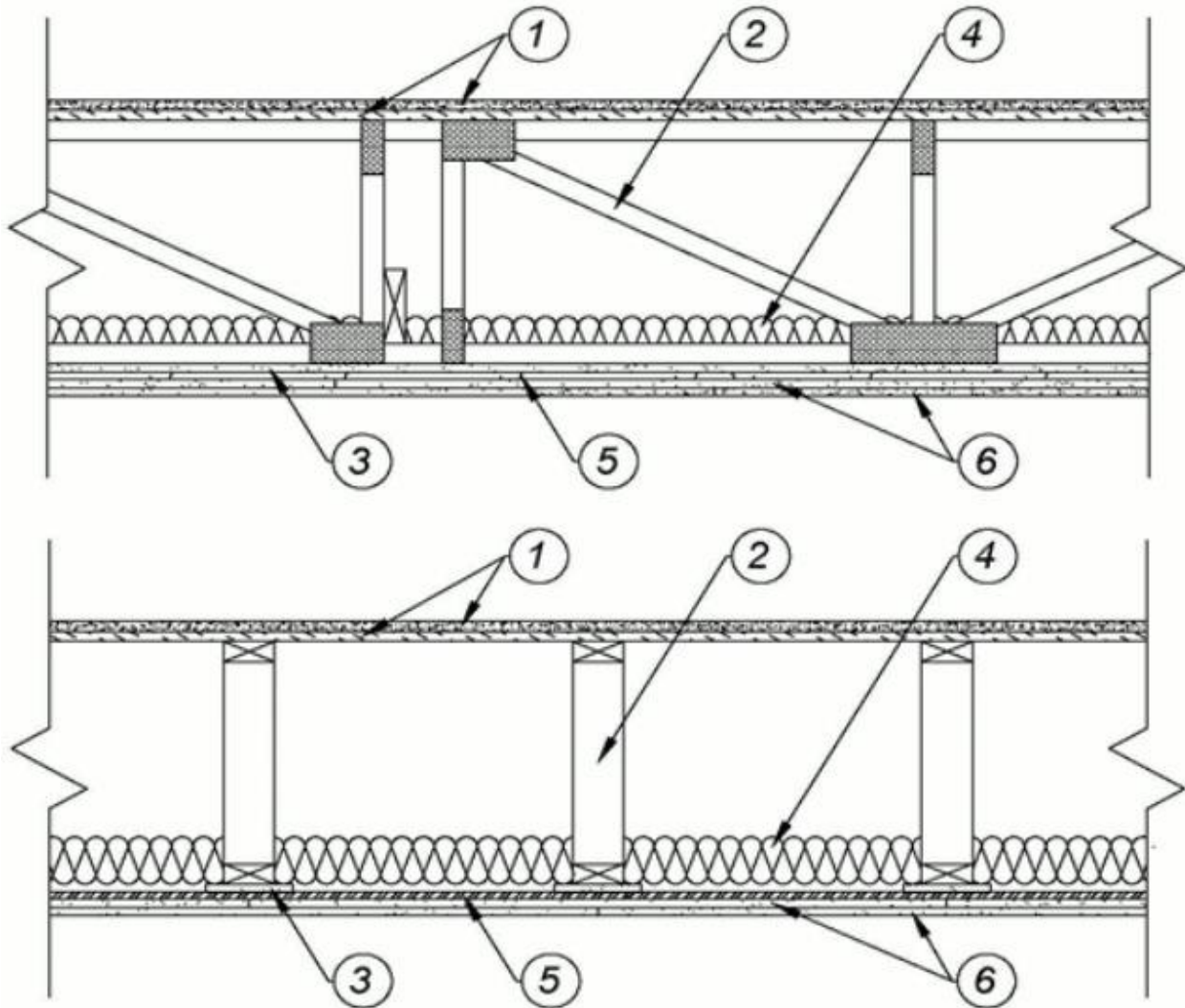

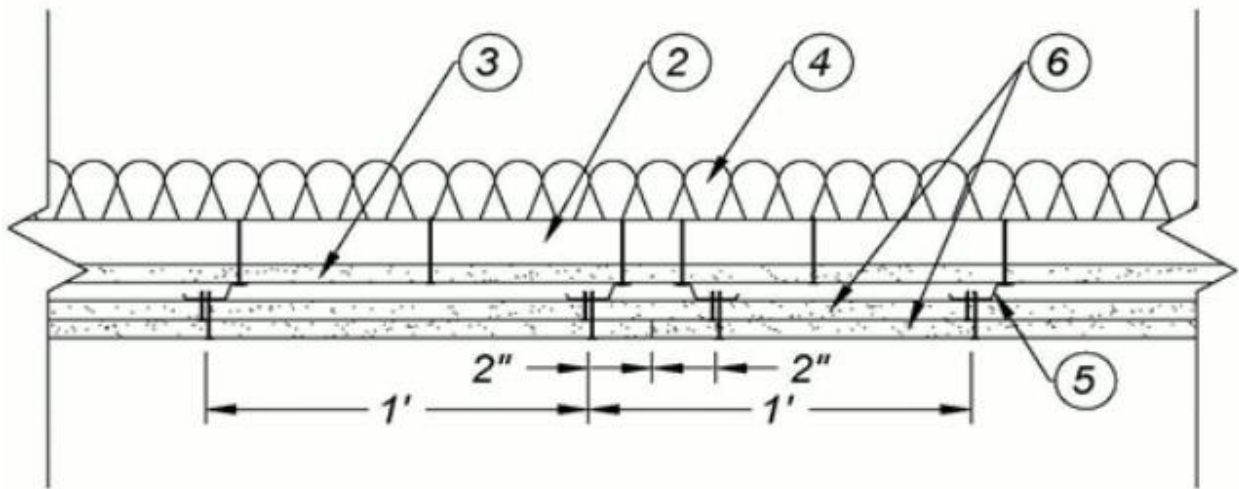

Flooring System — The flooring system shall consist of one of the following:

System No. 1

Subflooring — Nom 23/32 in. thick wood structural panels installed perpendicular to trusses with end joints staggered. Plywood or panels secured to trusses with construction adhesive and No. 8d nails, spaced 8 in. OC along each truss. Staples having equal or greater withdrawal and lateral resistance strength may be substituted for the 8d nails.

Vapor Barrier — (Optional) - Nom 0.010 in. thick commercial asphalt saturated felt.

Finish Flooring — Floor Topping Mixture* — Min 3/4 in. thickness of floor topping mixture having a minimum compressive strength of 1800 psi. Refer to manufacturer's instructions accompanying the material for specific mix design.

UNITED STATES GYPSUM CO — Type LRK

System No. 2

Structural Cement-Fiber Units* — Nom 3/4 in. thick, with long edges tongue and grooved. Long dimension of panels to be perpendicular to wood trusses with end joints staggered a min of 2 ft and centered over the trusses. Panels secured to wood trusses with 1-5/8 in. long, No. 8, self-countersinking wood screw spaced a max of 12 in. OC in the field with a screw located 1 in. and 2 in. from each edge, and 8 in. OC on the perimeter with a screw located 2 in. from each edge, located 1/2 in. from the end edges of the panel.

UNITED STATES GYPSUM CO — Types STRUCTO-CRETE, USGSP

System No. 3

Structural Cement-Fiber Units* — Nom 3/4 in. thick, with long edges tongue and grooved. Long dimension of panels to be perpendicular to wood trusses with end joints staggered a min of 2 ft and centered over the trusses. Panels secured to wood trusses with 1-5/8 in. long, No. 8, self-countersinking wood screw spaced a max of 12 in. OC in the field with a screw located 1 in. and 2 in. from each edge, and 8 in. OC on the perimeter with a screw located 2 in. from each edge, located 1/2 in. from the end edges of the panel.

UNITED STATES GYPSUM CO — Types STRUCTO-CRETE, USGSP

Finish Flooring - Floor Topping Mixture* — Min 3/4 in. thickness of floor topping mixture having a minimum compressive strength of 1800 psi. Refer to manufacturer's instructions accompanying the material for specific mix design.

UNITED STATES GYPSUM CO — Types LRK, HSLRK, CSD

USG MEXICO S A DE C V — Types LRK, HSLRK, CSD

Floor Mat Materials* — (Optional) - Floor mat material loose laid over the subfloor. Refer to manufacturer's instructions regarding the minimum thickness of floor topping over each floor mat material.

UNITED STATES GYPSUM CO — Types SAM, LEVELROCK® Brand Sound Reduction Board, LEVELROCK® Brand Floor Underlayment SRM-25

2. **Trusses** — Parallel chord trusses, spaced a max of 24 in. OC, fabricated from nom 2 by 4 lumber, with lumber oriented vertically or horizontally. Min truss depth is 18 in. Truss members secured together with min 0.0356 in. thick galv steel plates. Plates have 5/16 in. long teeth projecting perpendicular to the plane of the plate. The teeth are in pairs facing each other (made by the same punch), forming a split tooth type plate. Each tooth has a chisel point on its outside edge. These points are diagonally opposite each other for each pair. The top half of each tooth has a twist for stiffness. The pairs are repeated on approx. 7/8 in. centers with four rows of teeth per inch of plate width.

3. **Gypsum Board Batten Strip*** — 6 in. wide gypsum board strips cut from the same corresponding material chosen in Item 6. Gypsum board strips screw attached to the bottom chord of every truss with 2-1/4 in. long Type W bugle head steel screws spaced 12 in. OC.

CGC INC — Type ULIX

UNITED STATES GYPSUM CO — Type C, Type ULIX

USG BORAL DRYWALL SFZ LLC — Type C

4. **Batts and Blankets*** — Min. 3-1/2 glass fiber or mineral wool insulation bearing the UL Classification Marking as to Surface Burning Characteristics and/or Fire Resistance having a min. density of 0.5 pcf installed between bottom chords of trusses draped over gypsum board batten strips/resilient channels/gypsum panel ceiling membrane. Glass fiber batt width cut to fit snug between bottom chords of truss. See **Batts and Blankets** (BKNV or BZJZ) Categories for names of Classified companies.

5. **Resilient Channels** — Formed from min 25 MSG galv steel, spaced 12 in. OC perpendicular to trusses. Channels secured to each truss with 2-1/4 in. long Type W bugle head steel screws. Channels overlapped 4 in. at splices. Two channels, spaced 4 in. OC, oriented opposite at each gypsum panel end joint. All channels extend continuous across the entire length of the assembly.

5A. **Steel Framing Members*** — (Optional, Not Shown) — As an alternate to Item 5 — Furring channels and Steel Framing Members as described below:

a. **Furring Channels** — Formed of No. 25 ga galv steel, 2-3/8 in. wide by 7/8 in. deep, spaced 12 in. OC, perpendicular to trusses. Channels secured to trusses as described in Item b. Ends of adjoining

channels overlapped 6 in. and tied together with double strand of No. 18 SWG galvanized steel wire near each end of overlap. Additional channels shall extend min 6 in. beyond each side edge of panel.

b. **Steel Framing Members*** — Used to attach furring channels (Item a) to trusses (Item 2). Clips spaced 48 in. OC and secured to the bottom chord to alternating trusses with one No. 8 x 3-1/8 in. coarse drywall screw through center grommet. Furring channels are friction fitted into clips. Adjoining channels are overlapped as described in Item a. Additional clips required to hold furring channel that supports the gypsum board butt joints, as described in Item 6.

PLITEQ INC — Type Genie Clip

5B. **Alternate Steel Framing Members*** — (Optional, Not Shown) — As an alternate to Items 5 and 5A, furring channels and Steel Framing Members as described below.

a. **Furring Channels** — Formed of No. 25 MSG galv steel. 2-9/16 in. or 2-23/32 in. wide by 7/8 in. deep, spaced 12 in. OC, perpendicular to joists. Channels secured to joists as described in Item b. Ends of adjoining channels overlapped 6 in. and tied together with double strand of No. 18 SWG galv steel wire near each end of overlap. Additional channels shall extend min 6 in. beyond each side edge of panel.

b. **Steel Framing Members*** — Used to attach furring channels (Item a) to the wood joists (Item 2). Clips spaced a max of 48 in. OC. RSIC-1 and RSIC-1 (2.75) clips secured to alternating joists with No. 8 x 3-1/8 in. coarse drywall screw through the center grommet. Furring channels are friction fitted into clips. RSIC-1 clips for use with 2-9/16 in. wide furring channels. RSIC-1 (2.75) clips for use with 2-23/32 in. wide furring channels. Adjoining channels are overlapped as described in Item a. As an alternate, ends of adjoining channels may be overlapped 6 in. and secured together with two self-tapping No. 6 framing screws, min. 7/16 in. long at the midpoint of the overlap, with one screw on each flange of the channel. Additional clips required to hold furring channel that supports the wallboard butt joints, as described in Item 6.

PAC INTERNATIONAL L L C — Types RSIC-1 or RSIC-1 (2.75)

6. **Gypsum Board*** — Two layers of 5/8 in. thick, 48 in. wide gypsum panels installed with long dimension perpendicular to resilient/furring channels. Base layer gypsum panels secured with 1 in. long Type S bugle head steel screws spaced 8 in. OC, with screws located 4 in. from and on each side of the gypsum panel center-line, and 1-1/2 in. from side edges of the board. Face layer secured with 1-5/8 in. long Type S bugle head steel screws spaced 8 in. OC. End joints secured to both resilient channels as shown in end joint detail. When **Steel Framing Members** (Item 5A or 5B) are used, the butt joints in the gypsum board shall be supported by two furring channels. The two furring channels shall be spaced approximately 3-1/2 in. OC, and be attached to underside of the joist with one RSIC-1, RSIC-1 (2.75) or Genie clip at each end of the channel. Face layer tapered edges offset 24 in. from base layer tapered edges. Face layer butt joints offset min. 24 in. from base layer butt joints.

CGC INC — Type ULIX (finish rating 91 min.).

UNITED STATES GYPSUM CO — Type C (finish rating 98 min.), Type ULIX (finish rating 91 min.).

USG BORAL DRYWALL SFZ LLC — Type C (finish rating 98 min.).

7. **Finishing System** — (Not shown) — Vinyl, dry or premixed joint compound, applied in two coats to joints and screw-heads. Nom 2 in. wide paper tape embedded in first layer of compound over all joints. As an alternate, nom 3/32 in. thick veneer plaster may be applied to the entire surface of gypsum board.

*** Indicates such products shall bear the UL or cUL Certification Mark for jurisdictions employing the UL or cUL Certification (such as Canada), respectively.**

Last Updated on 2022-08-09