

Design No. **M513**
April 04, 2023

Unrestrained Assembly Rating — 1 Hr

Unrestrained Beam Rating — 1 Hr

This design was evaluated using a load design method other than the Limit States Design Method (e.g., Working Stress Design Method). For jurisdictions employing the Limit States Design Method, such as Canada, a load restriction factor shall be used — See Guide [BXUV](#) or [BXUV7](#)

* Indicates such products shall bear the UL or cUL Certification Mark for jurisdictions employing the UL or cUL Certification (such as Canada), respectively.

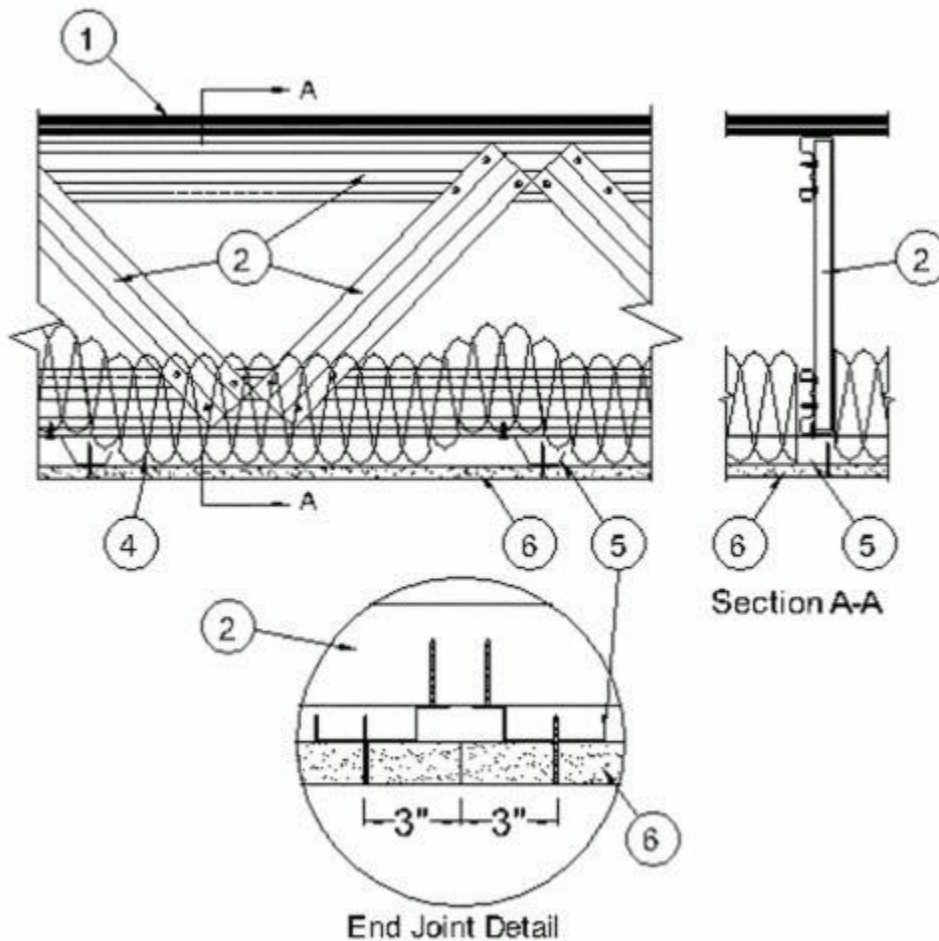

1. **Flooring System** — The flooring system shall consist of one of the following:

System No. 1

Subflooring — Min 23/32 in. thick wood structural panels, min grade "Underlayment" or "Single-Floor". Face grain of plywood or strength axis of panel to be perpendicular to trusses with joints staggered 4 ft. Plywood or panel mechanically fastened to trusses 12 in. OC in conjunction with construction adhesive.

Vapor Barrier - (Optional) — Nom 0.030 in thick commercial asphalt saturated felt.

Finish Flooring — Min 1 by 4 in. T & G lumber installed perpendicular to trusses, or min 15/32 in. thick wood structural panels, min grade "Underlayment" or "Single-Floor". Face grain of plywood or strength axis of panel to be perpendicular to trusses with joints staggered.

System No. 2

Subflooring — Min 23/32 in. thick wood structural panels, min grade "Underlayment" or "Single-Floor". Face grain of plywood or strength axis of panel to be perpendicular to trusses with joints staggered 4 ft. Plywood or panel mechanically fastened to trusses 12 in. OC in conjunction with construction adhesive.

Floor Mat Materials* - (Optional) — Floor mat material nom 5/64 in. (2mm) thick adhered to subfloor with Hacker Floor Primer. Primer to be applied to the surface of the mat prior to the placement of a min 1 in. of floor-topping mixture.

HACKER INDUSTRIES INC — Type Hacker Sound-Mat.

Alternate Floor Mat Materials - (Optional) — Floor mat material nom 1/4 in. (6mm) thick adhered to subfloor with Hacker Floor Primer. Primer to be applied to the surface of the mat prior to the placement of a min 1-1/4 in. (32mm) of floor-topping mixture.

HACKER INDUSTRIES INC — Type Hacker Sound-Mat II.

Alternate Floor Mat Materials - (Optional) — Floor mat material nom 1/8 in. (3mm) thick loose laid over the subfloor. Floor topping thickness shall be a min of 3/4 in. (19mm)

HACKER INDUSTRIES INC — FIRM-FILL SCM 125

Alternate Floor Mat Materials - (Optional) — Floor mat material nom 1/4 in. (6mm) thick loose laid over the subfloor. Floor topping thickness shall be a min of 1 in. (25mm)

HACKER INDUSTRIES INC — Type FIRM-FILL SCM 250, Quiet Qurl 55/025

Alternate Floor Mat Materials - (Optional) — Floor mat material nom 3/8 in. (10mm) thick loose laid over the subfloor. Floor topping thickness shall be a min of 1-1/4 in. (32mm)

HACKER INDUSTRIES INC — FIRM-FILL SCM 400, Quiet Qurl 60/040

Alternate Floor Mat Materials - (Optional) — Floor mat material nom 3/4 in. (19mm) thick loose laid over the subfloor. Floor topping thickness shall be a min of 1-1/2 in. (38mm)

HACKER INDUSTRIES INC — Type FIRM-FILL SCM 750, Quiet Qurl 65/075

Metal Lath (Optional) — For use with 3/8 in. (10 mm) floor mat materials, 3/8 in. expanded steel diamond mesh, 3.4 lbs/sq yd placed over the floor mat material. Hacker Floor Primer to be applied prior to the placement of the metal lath. When metal lath is used, floor topping thickness a nom 1-1/4 in. over the floor mat.

Finish Flooring - Floor Topping Mixture* — Min 3/4 in. thickness of floor topping mixture having a min compressive strength of 1100 psi. Mixture shall consist of 6.8 gal of water to 80 lbs of floor topping mixture to 1.9 cu ft of sand.

HACKER INDUSTRIES INC — Firm-Fill Gypsum Concrete, Firm-Fill 2010, Firm-Fill 3310, Firm-Fill 4010, Firm-Fill High Strength, Gyp-Span Radiant

System No. 3

Subflooring — Min 23/32 in. thick wood structural panels, min grade "Underlayment" or "Single-Floor". Face grain of plywood or strength axis of panel to be perpendicular to trusses with joints staggered 4 ft. Plywood or panel mechanically fastened to trusses 12 in. OC in conjunction with construction adhesive.

Finish Floor - Mineral and Fiber Board* — Min 1/2 in. thick, supplied in sizes ranging from 3 ft by 4 ft to 8 ft by 12 ft. All joints to be staggered a min of 12 in. with adjacent sub-floor joints.

HOMASOTE CO — Type 440-32 Mineral and Fiber Board

System No. 4

Subflooring — Min 23/32 in. thick wood structural panels, min grade "Underlayment" or "Single-Floor". Face grain of plywood or strength axis of panel to be perpendicular to trusses with joints staggered 4 ft. Plywood or panel mechanically fastened to trusses 12 in. OC in conjunction with construction adhesive.

Vapor Barrier - (Optional) — Nom 0.030 in thick commercial asphalt saturated felt.

Finish Flooring - Floor Topping Mixture* — Min 3/4 in. thickness of floor topping mixture having a minimum compressive strength of 1500 psi. Refer to manufacturer's instructions accompanying the material for specific mix design.

MAXXON CORP — Types Maxxon Standard and Maxxon High Strength

Floor Mat Materials* - (Optional) — Floor mat material loose laid over the subfloor. Refer to manufacturer's instructions regarding the minimum thickness of floor topping over each floor mat material.

MAXXON CORP — Encapsulated Sound Mat.

Floor Mat Reinforcement - (Optional) Refer to manufacturer's instructions regarding minimum thickness of floor topping for use with floor mat reinforcement.

Metal Lath - (Optional) - 3/8 in. expanded galvanized steel diamond mesh, 3.4 lbs/sq yd loose laid over the floor mat material.

Fiber Glass Reinforcement — (Optional) 0.015 in. thick PVC coated non-woven fiberglass mesh, 0.368 lbs./sq. yd loose laid over the floor mat material.

System No. 5

Subflooring — Min 23/32 in. thick wood structural panels, min grade "Underlayment" or "Single-Floor". Face grain of plywood or strength axis of panel to be perpendicular to trusses with joints staggered 4 ft. Plywood or panel mechanically fastened to trusses 12 in. OC in conjunction with construction adhesive.

Vapor Barrier — (Optional) Nom 0.030 in thick commercial asphalt saturated felt.

Finish Flooring — Floor Topping Mixture* — Min 3/4 in. thickness of floor topping mixture having a min compressive strength of 1000 psi. Refer to manufacturer's instructions accompanying the material for specific mix design.

FORMULATED MATERIALS LLC — Types FR-25, FR-30, and SiteMix

Floor Mat Material* — (Optional) Floor mat material nominal 2 - 9.5 mm thick loose laid over the subfloor. Floor topping shall be a min of 3/4 in.

FORMULATED MATERIALS LLC — Types M1, M2, M3, Elite, Duo, R1, and R2.

System No. 6

Subflooring — Min 23/32 in. thick wood structural panels, min grade "Underlayment" or "Single-Floor". Face grain of plywood or strength axis of panel to be perpendicular to trusses with joints staggered 4 ft. Plywood or panel mechanically fastened to trusses 12 in. OC in conjunction with construction adhesive.

Vapor Barrier — (Optional) - Nom 0.010 in. thick commercial asphalt saturated felt.

Finish Flooring - Floor Topping Mixture* — Min 3/4 in. thickness of floor topping mixture having a minimum compressive strength of 1800 psi. Refer to manufacturer's instructions accompanying the material for specific mix design.

UNITED STATES GYPSUM CO — Types LRK, HSLRK, CSD

USG MEXICO S A DE C V — Types LRK, HSLRK, CSD

Floor Mat Materials* — (Optional) - Floor mat material loose laid over the subfloor. Refer to manufacturer's instructions regarding the minimum thickness of floor topping over each floor mat material.

UNITED STATES GYPSUM CO — Types SAM, LEVELROCK® Brand Sound Reduction Board, LEVELROCK® Brand Floor Underlayment SRM-25

Alternate Floor Mat Materials* — (Optional) - Nom 3/8 in. thick floor mat material loose laid over the subfloor.

GRASSWORX L L C — Type SC50

Alternate Floor Mat Material* — (Optional) - Floor mat material nominal 3/8 in. thick loose laid over the subfloor. Floor topping shall be a min 3/4 in. thick. Thickness increased to min 1 in. for used with LEVELROCK® Brand Floor Underlayment SRM-25.

System No. 7

Subflooring — Min 15/32 in. thick wood structural panels, min grade "C-D" or "Sheathing". Face grain of plywood or strength axis of panels to be perpendicular to the joists with joints staggered.

Vapor Barrier — (Optional) - Commercial asphalt saturated felt, 0.030 in. thick.

Vapor Barrier — (Optional) - Nom 0.010 in. thick commercial rosin-sized building paper.

Finish Flooring* — Min 3/4 in. thickness of any Floor Topping Mixture bearing the UL Classification Marking as to Fire Resistance. See Floor- and Roof-Topping Mixtures (CCOX) category for names of Classified Companies.

Floor Mat Materials* — (Optional) - Nom. 1/4 in. thick loose laid over the subfloor. Floor topping thickness shall be a minimum of 3/4 in.

KEENE BUILDING PRODUCTS CO INC — Type Quiet Qurl 55/025 and Quiet Qurl 55/025 N

Alternate Floor Mat Materials* — (Optional) - Floor mat material Nom. 3/8 in. thick loose laid over the subfloor. Floor topping thickness shall be a minimum of 1 in.

KEENE BUILDING PRODUCTS CO INC — Type Quiet Qurl 60/040 and Quiet Qurl 60/040 N

Alternate Floor Mat Materials* — (Optional) - Floor mat material Nom. 3/4 in. thick loose laid over the subfloor. Floor topping thickness shall be a minimum of 1-1/2 in.

KEENE BUILDING PRODUCTS CO INC — Type Quiet Qurl 65/075, Quiet Qurl 65/075 N

Alternate Floor Mat Materials* — (Optional) - Floor mat material Nom. 1/8 in. thick loose laid over the subfloor. Floor topping thickness shall be a minimum of 3/4 in.

KEENE BUILDING PRODUCTS CO INC — Type Quiet Qurl 52/013 and Quiet Qurl 52/013 N

Alternate Floor Mat Materials* — (Optional) - Floor mat material Nom. 1/4 in. entangled net core with a compressible fabric attached to the bottom loose laid over the subfloor. Floor topping thickness shall be a minimum of 1 in.

KEENE BUILDING PRODUCTS CO INC — Quiet Qurl 55/025 MT and Quiet Qurl 55/025 N MT

System No. 8

Subflooring — Min 23/32 in. thick wood structural panels, min grade "Underlayment" or "Single-Floor". Face grain of plywood or strength axis of panel to be perpendicular to trusses with joints staggered 4 ft. Plywood or panel mechanically fastened to trusses 12 in. OC in conjunction with construction adhesive.

Vapor Barrier - (Optional) — Nom 0.030 in thick commercial asphalt saturated felt.

Finish Flooring - Floor Topping Mixture* — Min 3/4 in. thickness of floor topping mixture having a min compressive strength of 1000 psi. Refer to manufacturer's instructions accompanying the material for specific mix design.

ARCOSA SPECIALTY MATERIALS — AccuCrete® Types NexGen, Green, Prime and PrePour, AccuRadiant®, AccuLevel® Types G40, G50 and SD30

DEPENDABLE LLC — GSL M3.4, GSL K2.6, GSL-CSD or GSL RH

Floor Mat Material* — (Optional) - Floor mat material nominal 2 - 9.5 mm thick loose laid over the subfloor. Floor topping shall be a min of 3/4 in.

ARCOSA SPECIALTY MATERIALS — AccuQuiet® Types D13, D25, DX38, EM.125, EM.125S, EM.250, EM.250S, EM.375, EM.375S, EM.750, and EM.750S.

System No. 9

Subflooring — Min 23/32 in. thick T&G wood structural panels, min grade "Underlayment" or "Single-Floor". Face grain of plywood or strength axis of panels to be perpendicular to the trusses with end joints staggered 4 ft. Panels secured to trusses with construction adhesive and No. 6d ringed shank nails spaced 12 in. OC along each truss. Staples having equal or greater withdrawal and lateral resistance strength may be substituted for the 6d nails.

Gypsum Board* — One layer of nom 5/8 in. thick, 4 ft wide gypsum board, installed with long dimension perpendicular to joists. Gypsum board secured with 1 in. long No. 6 Type W bugle head steel screws spaced 12 in. OC and located a min of 1-1/2 in. from side and end joints. The joints of the gypsum board are to be staggered a minimum of 12 inches from the joints of the subfloor.

GEORGIA-PACIFIC GYPSUM L L C — Type DS

Floor Mat Materials* — (As an alternate to the single layer gypsum board) - Floor mat material loose laid over the subfloor.

MAXXON CORP — Encapsulated Sound Mat.

Gypsum Board* — (For use when floor mat is used) Two layers of nom 5/8 in. thick, 4 ft wide gypsum board, installed with long dimension perpendicular to joists on top of the floor mat material. Gypsum board secured to each other with 1 in. long No. 6 Type G bugle head steel screws spaced 12 in. OC and located a min of 1-1/2 in. from side and end joints. The joints of the gypsum board are to be staggered a minimum of 12 inches in between layers and from the joints of the subfloor.

GEORGIA-PACIFIC GYPSUM L L C — Type DS

System No. 10

Subflooring — Building Units* — Nom 3/4 in. thick, tongue and grooved boards. Long dimension of boards to be perpendicular to trusses with end joints staggered a min of 4 ft. and centered over the trusses. Boards secured to trusses with 1-1/4 in. long self-drilling, self-tapping screws spaced a max of 12 in. OC in the field with screws located 1 in. from long edge, and max 8 in. OC along the end joints with screws located 1/2 in. from end joint.

ECTEK INTERNATIONAL INC — Type MegaBoard

System No. 11

Subflooring — Min 23/32 in. thick wood structural panels, min grade "Underlayment" or "Single-Floor". Face grain of plywood or strength axis of panel to be perpendicular to trusses with joints staggered 4 ft. Plywood or panel mechanically fastened to trusses 12 in. OC in conjunction with construction adhesive.

Finish Flooring - Floor Topping Mixture* — Min 1 in. thickness of floor topping mixture having a min compressive strength of 4500 psi. Refer to manufacturer's instructions accompanying the material for specific mix design.

SIKA DEUTSCHLAND GMBH — Type SCHONOX AP Rapid Plus

System No. 12

Subflooring — Min 23/32 in. thick wood structural panels, min grade "Underlayment" or "Single-Floor". Face grain of plywood or strength axis of panel to be perpendicular to trusses with joints staggered 4 ft. Plywood or panel mechanically fastened to trusses 12 in. OC in conjunction with construction adhesive.

Vapor Barrier — (Optional) - Nom 0.030 in thick commercial asphalt saturated felt.

Finish Flooring - Floor Topping Mixture* — Min 3/4 in. thickness of any Floor Topping Mixture bearing the UL Classification Marking as to Fire Resistance. See Floor- and Roof-Topping Mixtures (CCOX) category for names of Classified Companies. Refer to the manufacturer's instructions accompanying the material and/or contact the manufacturer's technical support for specific mix design and minimum thickness recommended for use with eligible floor mat(s).

Floor Mat Materials* — (Optional, Not Shown) - Floor mat material loose laid over the subfloor. Refer to manufacturer's instructions regarding the minimum thickness of floor topping over each floor mat material.

LOW & BONAR INC — EnkaSonic® by Colbond a member of the Low & Bonar group Types 125, 250, 250 Plus, 400, 400 Plus, 750 and 750 Plus.

Floor Mat Reinforcement — (Optional) - Refer to manufacturer's instructions regarding minimum thickness of floor topping for use with floor mat reinforcement.

Metal Lath — (Optional) — Expanded steel diamond mesh, 2.5 lb / sq yd loose laid over floor mat material.

Fiberglass Mesh Reinforcement — (Optional) — Coated non-woven glass fiber mesh grid loose laid over floor mat material.

System No. 13

Subflooring — Min 23/32 in. thick wood structural panels, min grade "Underlayment" or "Single-Floor". Face grain of plywood or strength axis of panel to be perpendicular to trusses with joints staggered 4 ft. Plywood or panel mechanically fastened to trusses 12 in. OC in conjunction with construction adhesive.

Finish Floor -- Building Units* — Min 1/2 in. thick, supplied in 4 by 8 ft panels, fastened to trusses through subfloor. All joints to be staggered a min of 12 in. with sub-floor joints.

ECTEK INTERNATIONAL INC — Type MegaBoard, 1/2 in. thick

2. **Structural Steel Members*** — Pre-fabricated light gauge steel truss system consisting of cold-formed, galvanized steel chord and web sections. Trusses fabricated in various sizes, depths, and from various steel thickness. Minimum truss depth is 12 in. Trusses spaced max 48 in. OC.

AEGIS METAL FRAMING, DIV OF MITEK — Ultra-Span, Pre-fabricated Light Gauge Steel Truss System

TRUSSTEEL, DIV OF ITW BUILDING COMPONENTS INC — TrusSteel

3. **Bridging - (Not Shown)** — Location of lateral bracing for truss chord and web sections to be specified on truss engineering.

4. **Batts and Blankets* (Optional)** — Any thickness of mineral wool or glass fiber insulation fitted in the concealed space, draped over the resilient channels and gypsum board ceiling membrane. Any mineral wool or glass fiber insulation bearing the UL Classification Marking for Surface Burning Characteristics having a flame spread index of 25 or less and a smoke developed index of 50 or less may be used.

See **Batts and Blankets** (BKNV) category in the Building Materials Directory for names of manufacturers.

4A. **Loose Fill Material* - (Optional)** — As an alternate to Item 4, any thickness of loose fill material installed on top of gypsum board ceiling membrane. Any loose fill material bearing the UL Classification Marking for Surface Burning Characteristics having a flame spread index of 25 or less and a smoke developed index of 50 or less may be used.

See **Loose Fill Materials** (BPHX) category in the Building Materials Directory for names of manufacturers.

5. **Resilient Channels** — Resilient channels formed of 25 MSG galv steel, installed perpendicular to the trusses spaced max 16 in. OC. When batt insulation (Item 4) is fitted in the concealed space and draped over the resilient channel/gypsum board ceiling membrane, or when loose fill insulation (Item 4A) is used, resilient channel spacing shall be max 12 in. OC. Channels secured to each truss with 1/2 in. long Type S12 steel screws. Channel splices located beneath trusses and overlapped 4 in. Two channels, spaced 6 in. OC, oriented opposite each gypsum board end joint as shown in end joint detail. Additional channels shall extend min 6 in. beyond each side edge of board. As an alternate to the resilient channels, furring channels (Item 5A) or **Steel Framing Members*** (Item 5B) may be used.

5A. **Furring Channels - (Not Shown)** — As an alternate to Item 5, resilient channels, double legged formed of 25 MSG galv steel, 2-7/8 in. wide by 1/2 in. deep, installed perpendicular to the trusses spaced max 16 in. OC. When batt insulation (Item 4) is fitted in the concealed space and draped over the resilient channel/gypsum board ceiling membrane, or when loose fill insulation (Item 4A) is used, resilient channel spacing shall be max 12 in. OC. Channels secured to each truss with 1/2 in. long Type S12 steel screws or with No. 18 SWG galv steel wire double strand saddle ties. Channel splices located beneath trusses and overlapped 4 in. Channels tied together at splices with double strand of No. 18 SWG galv steel wire at each end of overlap. Two channels, spaced 6 in. OC, oriented opposite each gypsum board end joint as shown in end joint detail. Additional channels shall extend min 6 in. beyond each side edge of board.

5B. **Alternate Steel Framing Members* - (Not Shown)** — As an alternate to Items 5 and 5A, main runners, cross tees or channels, and wall angle or channels as listed below:

a. **Main Runners** — Nom 10 or 12 ft long, 15/16 in. or 1-1/2 in. wide face, spaced 4 ft OC perpendicular to trusses. Main runners suspended a min of 2 in. beneath bottom chord of trusses with min 12 SWG galv steel hanger wires spaced 48 in. OC. Hanger wires to be located adjacent to main runner/cross tee intersections.

b. **Cross Tees or Channels** — Cross tees, nom 4 ft long, 15/16 in or 1-1/2 in. wide face, or cross channels nom 4 ft long, 1-1/2 in. wide face, installed perpendicular to the main runners, spaced 16 in. OC. Additional cross tees or cross channels used at 8 in. from each side of butted gypsum board end joints. The cross tees or cross channels may be riveted or screw attached to the wall angle or channel to facilitate the ceiling installation.

c. **Wall Angle or Channel** — Used to support steel framing member ends and for screw attachment of the gypsum board. Min 0.016 in. thick painted or galvanized steel angle with 1 in. legs or min 0.016 in. thick painted or galvanized steel channel with a 1 by 1 1/2 by 1 in. profile, attached to walls at perimeter of ceiling with fasteners 16 in. OC.

CGC INC — Types DGL, RX

USG INTERIORS LLC — Types DGL, RX

5C. **Steel Framing Members*** — (Optional, Not Shown) — As an alternate to Item 5.

a. **Furring Channels** — Formed of No. 25 MSG galv steel, nominal 2-1/2 in. wide by 7/8 in. deep, spaced as indicated in Item 5, perpendicular to trusses. Channels secured to Cold Rolled Channels at every intersection with a 3/4 in. TEK screw through each furring channel leg. Ends of adjoining channels overlapped 12 in. and fastened together with two double strand No. 18 SWG galv steel wire ties, one at each end of overlap, or with two 3/4 in. TEK screws in each leg of the overlap section. Two furring channels used at end joints of gypsum board (Item 6), each extending a min of 6 in. beyond both side edges of the board.

b. **Cold Rolled Channels** — 1-1/2 in. by 1/2 in., formed from No. 16 ga. galv steel, positioned vertically and parallel to trusses, friction-fitted into the channel caddy on the Steel Framing Members (Item 5Cd) and secured with two 3/4 in. TEK screws. Adjoining lengths of cold rolled channels lapped min. 12 in. and secured along bottom legs with four 3/4 in. TEK screws and wire-tied together with two double strand 18 SWG galv steel wire ties, one at each end of overlap.

c. **Blocking** — Where truss design does not permit direct, full contact of the hanger bracket, a piece of nominal 3-5/8 in. x 20 ga. steel stud (blocking), min. 12 in. long to permit full contact of the hanger bracket, to be secured vertically to the side of the trusses at the top and bottom of the blocking at each Steel Framing Member (Item 5Cd) location with minimum 2-1/2 in. screws.

d. **Steel Framing Members*** — Spaced 48 in. OC. max along truss, and secured to the truss on alternating trusses with two, No. 10-16 TEK screws through mounting holes on the hanger bracket.
PAC INTERNATIONAL L L C — Type RSIC-SI-CRC EZ Clip

5D. **Steel Framing Members*** — (Optional, Not Shown) — As an alternate to Item 5.

a. **Furring Channels** — Formed of No. 25 MSG galv steel, nominal 2-1/2 in. wide by 7/8 in. deep, spaced as indicated in Item 5, perpendicular to trusses and friction fit into Steel Framing Members (Item 5Dc). Ends of adjoining channels overlapped 6 in. and tied together with double strand of No. 18 SWG galv steel wire near each end of overlap or with two TEK screws along each leg of the 6 in. overlap. Two furring channels used at end joints of gypsum board (Item 6). Butt joint channels held in place by strong back channels placed upside down, on top of, and running perpendicular to primary furring channels, extending 6 in. longer than length of gypsum side joint. Strong back channels spaced maximum 48 in. OC. Strong back channels secured to every intersection of primary furring channels with four 7/16 in. pan head screws, two along each of the legs at intersections. Butt joint channels run perpendicular to strong back channels and shall be minimum 6 in. longer than length of joint, secured to strong back channels with 7/16 in. pan head screws, two along each of the legs at intersection with strong back channels.

b. **Blocking** — Where truss design does not permit direct, full contact of the hanger bracket, a piece of nominal 3-5/8 in. x 20 ga. steel stud (blocking), min. 12 in. long to permit full contact of the hanger bracket, to be secured vertically to the side of the trusses at the top and bottom of the blocking at each Steel Framing Member (Item 5Dc) location with minimum 2-1/2 in. screws.

c. **Steel Framing Members*** — Used to attach furring channels (Item 5Da) to trusses. Clips spaced 48 in. OC and secured along truss webs at each furring channel intersection with min. 3/4 in. long self-drilling No. 10-16 TEK screws through each of the provided hole locations. Furring channels are friction fitted into clips.

PAC INTERNATIONAL L L C — Type RSIC-S1-1 Ultra

5E. **Steel Framing Members*** — (Optional, Not Shown) — As an alternate to Item 5.

a. **Furring Channels** — Formed of No. 25 MSG galv steel. 2-9/16 in. wide by 7/8 in. deep, spaced as described in item 5, perpendicular to trusses. Channels secured to trusses as described in Item b. Ends of adjoining channels overlapped 6 in. and tied together with double strand of No. 18 SWG galv steel wire near each end of overlap.

b. **Steel Framing Members*** — Used to attach furring channels (Item a) to the steel trusses (Item 2). Clips spaced a max of 48 in. OC. RSIC-1 clips secured to trusses with No. 8 x 1-5/8 in. fine thread screw through the center grommet. Furring channels are friction fitted into clips. RSIC-1 clips for use with 2-9/16 in. wide furring channels. Adjoining channels are overlapped as described in Item a. As an alternate, ends of adjoining channels may be overlapped 6 in. and secured together with two self-tapping No. 6 framing screws, min. 7/16 in. long at the midpoint of the overlap, with one screw on each flange of the channel.

PAC INTERNATIONAL L L C — Type RSIC-1

6. **Gypsum Board*** — For use with resilient channels (Item 5) or furring channels (Item 5A) - Nom 5/8 in. thick, 48 in. wide gypsum board installed with long dimension perpendicular to resilient channels. Gypsum board secured with 1 in. long Type S bugle head steel screws spaced 12 in. OC along butted end joints and in the field. End joints secured to both pieces of resilient channel as shown in end joint detail. When batt insulation (Item 4) is fitted in the concealed space and draped over the resilient channel/gypsum board ceiling membrane, or when loose fill insulation (Item 4A) is used, screw spacing shall be 8 in. OC along butted end joints and in the field.

When **Steel Framing Members** (Item 5C) are used, nom 5/8 in. thick, 4 ft wide gypsum board, installed as described in Item 6. Adjacent butt joints staggered minimum 48 in. OC.

When **Steel Framing Members** (Item 5D) are used, nom 5/8 in. thick, 4 ft wide gypsum board, installed as described in Item 6. Butt joints staggered minimum 24 in. OC.

When **Steel Framing Members** (Item 5E) are used, gypsum panels installed with long dimensions perpendicular to furring channels. Panels attached to the furring channels using 1 in. long Type S bugle-head steel screws spaced 8 in. OC along butted end joints and in the field of the panel. Butted end joints shall be staggered min. 2 ft within the assembly, and occur midway between the continuous furring channels. Each end of each gypsum panel shall be supported by a single length of furring channel equal to the width of the gypsum panel plus 6 in. on each end. The two support furring channels shall be spaced approximately 3-1/2 in. OC, and be attached with one clip at each end of the channel.

AMERICAN GYPSUM CO — Type AG-C

6A. **Alternate Gypsum Board*** — For use with **Steel Framing Members*** (Item 5B) - Nom 5/8 in. thick, 48 in. wide gypsum board installed with long dimension parallel to the main runners. Gypsum board fastened to each cross tee or channel with five drywall screws, with one screw located at the midspan of the cross tee or channel, one screw located 12 in. from and on each side of the cross tee or channel mid span and one screw located 1-1/2 in. from each wallboard side joint. Except at gypsum board end joints, gypsum board screws shall be located 1/2 in. from the joint. Gypsum board fastened to main runners with drywall screws 1/2 in. from side joints, midway between intersections with cross tees or channels (16 in. OC). End joints of adjacent gypsum board sheets shall be staggered not less than 32 in. Gypsum board sheets screw attached to leg of wall angle with drywall screws spaced 12 in. OC. When batt insulation (Item 4) is fitted in the concealed space and

draped over the resilient channel/gypsum board ceiling membrane, or when loose fill insulation (Item 4A) is used, screws spacing shall be 8 in. OC.

AMERICAN GYPSUM CO — Type AG-C

7. **Finishing System - (Not Shown)** — Vinyl, dry or premixed joint compound, applied in two coats to joints and screw-heads. Nom 2 in. wide paper tape embedded in first layer of compound over all joints. As an alternate, nom 3/32 in. thick veneer plaster may be applied to the entire surface of gypsum board.

8. **Steel Beam - (Optional, Not Shown)** — W8x35 min size, used to support structural steel members (Item 2) at ends.

*** Indicates such products shall bear the UL or cUL Certification Mark for jurisdictions employing the UL or cUL Certification (such as Canada), respectively.**

Last Updated on 2023-04-04