

# Design No. M501

April 04, 2023

**Unrestrained Assembly Rating — 1 Hr.  
Finish Rating — 23 Min (See Items 5 or 5A)**

**This design was evaluated using a load design method other than the Limit States Design Method (e.g., Working Stress Design Method). For jurisdictions employing the Limit States Design Method, such as Canada, a load restriction factor shall be used — See Guide [BXUV](#) or [BXUV7](#)**

**\* Indicates such products shall bear the UL or cUL Certification Mark for jurisdictions employing the UL or cUL Certification (such as Canada), respectively.**

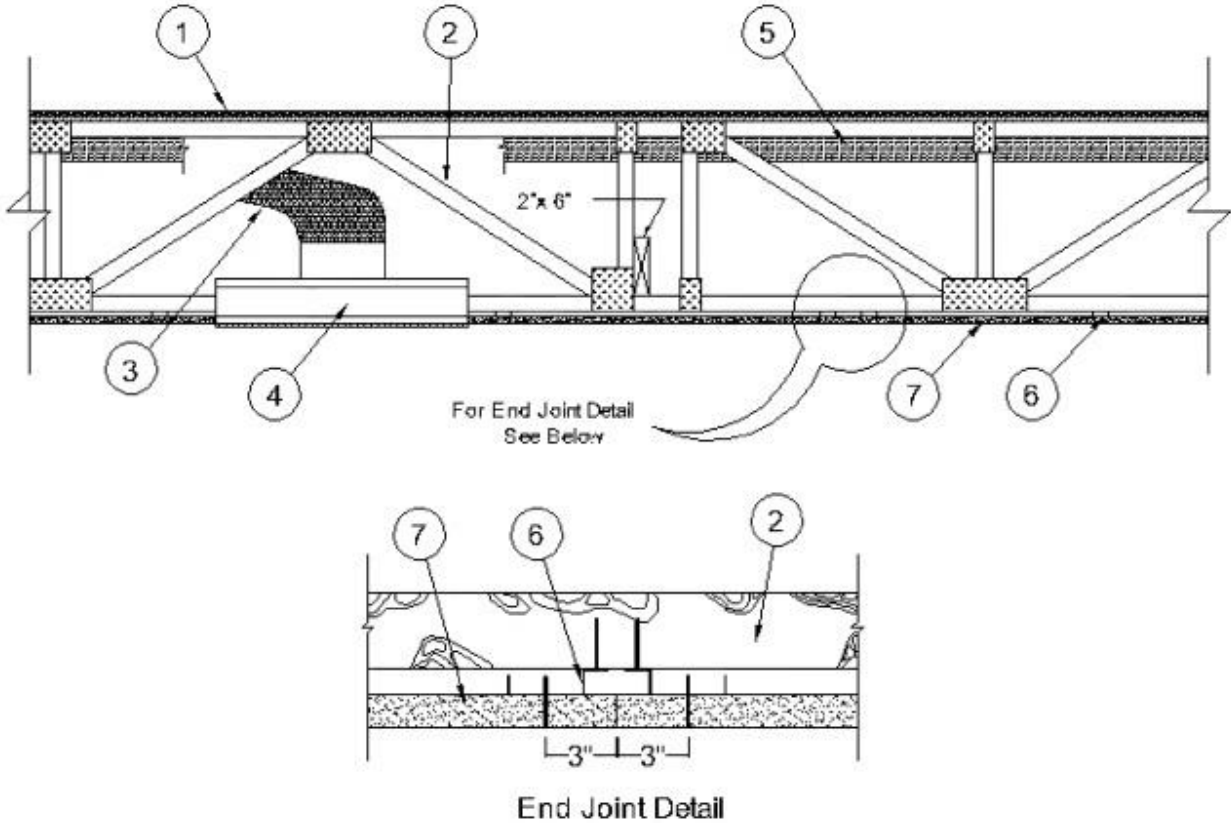

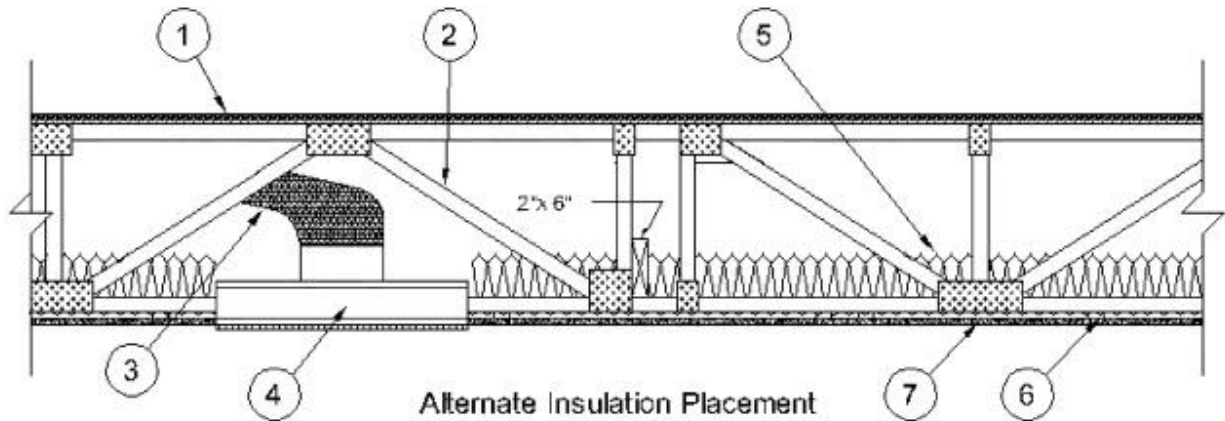

1. **Flooring System** — The flooring system shall consist of one of the following:

**System No. 1**

**Subflooring** — Min 15/32 in. thick wood structural panels, min grade "C-D" or "Sheathing". Face grain of plywood or strength axis of panels to be perpendicular to the joists with joints staggered.

**Vapor Barrier** — (Optional) - Commercial asphalt saturated felt, 0.030 in. thick.

**Vapor Barrier** — (Optional) - Nom 0.010 in. thick commercial rosin-sized building paper.

**Finish Flooring\*** — Min 3/4 in. thickness of any Floor Topping Mixture bearing the UL Classification Marking as to Fire Resistance. See Floor- and Roof-Topping Mixtures (CCOX) category for names of Classified Companies. Refer to the manufacturer's instructions accompanying the material and/or contact the manufacturer's technical support for specific mix design and minimum thickness recommended for use with eligible floor mat(s).

**Floor Mat Materials\*** — (Optional) - Nom. 1/4 in. thick loose laid over the subfloor. Floor topping thickness shall be a minimum of 3/4 in.

**KEENE BUILDING PRODUCTS CO INC** — Type Quiet Qurl 55/025 and Quiet Qurl 55/025 N

**Alternate Floor Mat Materials\*** — (Optional) - Floor mat material Nom. 3/8 in. thick loose laid over the subfloor. Floor topping thickness shall be a minimum of 1 in.

**KEENE BUILDING PRODUCTS CO INC** — Type Quiet Qurl 60/040 and Quiet Qurl 60/040 N

**Alternate Floor Mat Materials\*** — (Optional) - Floor mat material Nom. 3/4 in. thick loose laid over the subfloor. Floor topping thickness shall be a minimum of 1-1/2 in.

**KEENE BUILDING PRODUCTS CO INC** — Type Quiet Qurl 65/075, Quiet Qurl 65/075 N

**Alternate Floor Mat Materials\*** — (Optional) - Floor mat material Nom. 1/8 in. thick loose laid over the subfloor. Floor topping thickness shall be a minimum of 3/4 in.

**KEENE BUILDING PRODUCTS CO INC** — Type Quiet Qurl 52/013 and Quiet Qurl 52/013 N

**Alternate Floor Mat Materials\*** — (Optional) - Floor mat material Nom. 1/4 in. entangled net core with a compressible fabric attached to the bottom loose laid over the subfloor. Floor topping thickness shall be a minimum of 1 in.

**KEENE BUILDING PRODUCTS CO INC** — Quiet Qurl 55/025 MT and Quiet Qurl 55/025 N MT

### **System No. 2**

**Subflooring** — Min 15/32 in. thick wood structural panels, min grade "C-D" or "Sheathing". Face grain of plywood or strength axis of panels to be perpendicular to the joists with joints staggered.

**Vapor Barrier** — (Optional) — Nom 0.030 in. thick commercial asphalt saturated felt.

**Vapor Barrier** — (Optional) — Nom 0.010 in. thick commercial rosin-sized building paper.

**Finish Flooring — Floor Topping Mixture\*** — Min 3/4 in. thickness of floor topping mixture having a minimum compressive strength of 1800 psi. Refer to manufacturer's instructions accompanying the material for specific mix design.

**UNITED STATES GYPSUM CO** — Types LRK, HSLRK, CSD

**USG MEXICO S A DE C V** — Types LRK, HSLRK, CSD

**Floor Mat Materials\*** — (Optional) — Floor mat material loose laid over the subfloor. Refer to manufacturer's instructions regarding the minimum thickness of floor topping over each floor mat material.

**UNITED STATES GYPSUM CO** — Types SAM, LEVELROCK® Brand Sound Reduction Board, LEVELROCK® Brand Floor Underlayment SRM-25

### **System No. 3**

**Subflooring — Building Units\*** — Nom 3/4 in. thick, tongue and grooved boards. Long dimension of boards to be perpendicular to trusses with end joints staggered a min of 4 ft. and centered over the trusses. Boards secured to trusses with 2 in. long self-drilling, self-tapping screws spaced a max of 12 in. OC in the field with screws located 1 in. from long edge, and max 8 in. OC along the end joints with screws located 1/2 in. from end joint.

**ECTEK INTERNATIONAL INC** — Type MegaBoard

**Vapor Barrier** — (Optional) - Commercial asphalt saturated felt, 0.030 in. thick.

**Vapor Barrier** — (Optional) - Nom 0.010 in. thick commercial rosin-sized building paper.

**Finish Flooring\*** — Min 3/4 in. thickness of any Floor Topping Mixture bearing the UL Classification Marking as to Fire Resistance. See Floor- and Roof-Topping Mixtures (CCOX) category for names of Classified Companies. Refer to the manufacturer's instructions accompanying the material and/or contact the manufacturer's technical support for specific mix design and minimum thickness recommended for use with eligible floor mat(s).

**Floor Mat Materials\*** — (Optional) - Nom. 1/4 in. thick loose laid over the subfloor. Floor topping thickness shall be a minimum of 3/4 in.

**KEENE BUILDING PRODUCTS CO INC** — Type Quiet Qurl 55/025 and Quiet Qurl 55/025 N.

**Alternate Floor Mat Materials\*** — (Optional) - Floor mat material Nom. 3/8 in. thick loose laid over the subfloor. Floor topping thickness shall be a minimum of 1 in.

**KEENE BUILDING PRODUCTS CO INC** — Type Quiet Qurl 60/040 and Quiet Qurl 60/040 N.

**Alternate Floor Mat Materials\*** — (Optional) - Floor mat material Nom. 3/4 in. thick loose laid over the subfloor. Floor topping thickness shall be a minimum of 1-1/2 in.

**KEENE BUILDING PRODUCTS CO INC** — Type Quiet Qurl 65/075, Quiet Qurl 65/075 N.

**Alternate Floor Mat Materials\*** — (Optional) - Floor mat material Nom. 1/8 in. thick loose laid over the subfloor. Floor topping thickness shall be a minimum of 3/4 in.

**KEENE BUILDING PRODUCTS CO INC** — Type Quiet Qurl 52/013 and Quiet Qurl 52/013 N.

**Alternate Floor Mat Materials\*** — (Optional) - Floor mat material Nom. 1/4 in. entangled net core with a compressible fabric attached to the bottom loose laid over the subfloor. Floor topping thickness shall be a minimum of 1 in.

**KEENE BUILDING PRODUCTS CO INC** — Quiet Qurl 55/025 MT and Quiet Qurl 55/025 N MT.

2. **Trusses** — Parallel chord trusses, spaced a max of 24 in. OC, fabricated from nom 2 by 4 lumber, with lumber oriented vertically or horizontally. Min truss depth is 12 in. when no **Ceiling Damper\*** is used and 18 in. when a **Ceiling Damper\*** is used. Truss members secured together with min 0.0356 in. thick galvanized steel plates. Plates have 5/16 in. long teeth projecting perpendicular to the plane of the plate. The teeth are in pairs facing each other (made by the same punch), forming a split tooth type plate. Each tool has a chisel point on its outside edge. These points are diagonally opposite each other for each pair. The top half of each tooth has a twist for stiffness. The pairs are repeated on approx. 7/8 in. centers with four rows of teeth per inch of plate width.

3. **Air Duct\*** — Optional- for use with ceiling dampers. - Any UL Class 0 or Class 1 flexible air duct installed in accordance with the instructions provided by the damper manufacturer.

4. **Ceiling Damper\*** — Optional- Max nom 20 in. long by 18 in. wide by 2-1/8 in. high, fabricated from galvanized steel. Plenum box max size nom 21 in. long by 18 in. wide by 16 in. high fabricated from either galvanized steel or Classified Air Duct Materials bearing the UL Classification Marking for Class 0 or Class 1 rigid air duct material. Installed in accordance with the instructions provided by the manufacturer. Max damper openings not to exceed 180 sq in. per 100 sq ft of ceiling area.

**NAILOR INDUSTRIES INC** — Types 0755, 0755A, 0756, 0756D, 0757, 0757D, 0757FP, 0757DFP, 0758, 0759, 0760, 0761, 0762, CRD5, CRD5D, CRD6, CRD6D, CRD6FP, CRD6DFP

**SAFE AIR DOWCO** — 0455, 0455A, 0456, 0456D, 0457, 0457D, 0457-DB, 0457-CB, 0463-FB, 0457-EB, 0463-GB, 0463

4A **Alternate Ceiling Damper\*** — Optional —. Max nom 21 in. long by 18 in. wide, fabricated from galvanized steel. Plenum box max size nom 21 in. long by 18 in. wide by 14 in. high (inner dimension) fabricated from either galvanized steel or min 1 in. thick Listed Duct Board bearing the UL Listing

Marking having a min R-Value of 4.3. Installed in accordance with the instructions provided by the manufacturer. Max damper openings not to exceed 180 sq in. per 100 sq ft of ceiling area.

**GREENHECK FAN CORP** — Model CRD-1WT

**4B Alternate Ceiling Damper\*** — (Optional) — Max nom 12 in. long by 12 in. wide with an 8 in. diameter damper, fabricated from galvanized steel. Installed in accordance with the instructions provided by the manufacturer. Max damper openings not to exceed 72 sq in. per 100 sq ft of ceiling area.

**GREENHECK FAN CORP** — Model CRD-2WT

**4C. Alternate Ceiling Damper\*** — (Optional - . Max nom 11-1/8 in. long by 13-5/8 in. wide, fabricated from galvanized steel. Installed in accordance with the instructions provided by the manufacturer. Max damper openings not to exceed 76 sq in. per 100 sq ft of ceiling area.

**GREENHECK FAN CORP** — Model CRD-310WT

**4D. Alternate Ceiling Damper\*** — (Optional -) Max nom 12-3/8 in. long by 14-1/2 in. wide, fabricated from galvanized steel. Installed in accordance with the instructions provided by the manufacturer. Max damper openings not to exceed 90 sq in. per 100 sq ft of ceiling area.

**GREENHECK FAN CORP** — Model CRD-320WT

**4E. Alternate Ceiling Damper\*** — (Optional- Max nom 10-3/8 in. long by 10-3/8 in. wide, fabricated from galvanized steel. Installed in accordance with the instructions provided by the manufacturer. Max damper openings not to exceed 54 sq in. per 100 sq ft of ceiling area.

**GREENHECK FAN CORP** — Model CRD-300WT

**5. Batts and Blankets\*** — (Optional) - Glass fiber or mineral wool insulation, max 3-1/2 in, thick, bearing the UL Classification Marking as to Surface Burning Characteristics and/or Fire Resistance. May be secured against the subflooring with staples at 12 in. OC or held suspended in the concealed space with 0.090 in. diam galv steel wires attached to the wood trusses at 12 in. OC. When the resilient channels are spaced a max of 12 in. OC or when the Steel Framing Members (Item 6B) are used, there is no limit in the overall thickness of insulation, and the insulation can be secured against the subflooring, held suspended in the concealed space or draped over the resilient channels (or Steel Framing Members) and gypsum panel membrane. The finished rating has only been determined when the insulation is secured to the subflooring.

**5A. Loose Fill Material\*** — (Optional) - As an alternate to Item 5, when the resilient channels (Item 6) are spaced a maximum of 12 in. OC, or when the Steel Framing Members (Item 6B) are used - Any loose fill material bearing the UL Classification Marking for Surface Burning Characteristics. There is no limit in the overall thickness of insulation. The finished rating when loose fill material is used has not been determined.

**6. Resilient Channels** — For use with Item 7. Resilient channels formed of 25 MSG thick galv steel, spaced 16 in. OC perpendicular to trusses when no insulation is used or insulation is installed to the underside of the wood floor. When insulation is applied over the resilient channel/gypsum panel ceiling membrane, the resilient channel spacing shall be reduced to 12 in. OC. Channels secured to each truss with 1-1/4 in. long Type S bugle head steel screws. Channels overlapped 4 in. at splices.

Two channels, spaced 6 in. OC, oriented opposite each gypsum panel end joint as shown in the above illustration. Additional channels shall extend min 6 in. beyond each side edge of panel.

**6A. Resilient Channels** — For use with Item 7A. Resilient channels formed of 25 MSG thick galv steel, spaced 24 in. OC perpendicular to trusses. Spaced 16 in. OC perpendicular to trusses when insulation is installed to the underside of the wood floor. When insulation is applied over the resilient channel/gypsum panel ceiling membrane, the resilient channel spacing shall be reduced to 12 in. OC. Channels secured to each truss with 1-1/4 in. long Type S bugle head steel screws. Channels overlapped 4 in. at splices. Two channels, spaced 6 in. OC, oriented opposite each gypsum panel end joint as shown in the above illustration. Additional channels shall extend min 6 in. beyond each side edge of panel.

**6B. Steel Framing Members\* - (Not Shown)** — As an alternate to Item 6 and 6A.

a. **Main Runners** — Nom 10 or 12 ft long, 15/16 in. or 1-1/2 in. wide face, spaced 4 ft OC perpendicular to trusses. Main runners hung a min of 2 in. from bottom chord of trusses with 12 SWG galv steel wire. Wires spaced max 48 in. OC.

b. **Cross tees or channels** — Cross tees, nom 4 ft long, 15/16 in. or 1-1/2 in. wide face, or cross channels, nom 4 ft long, 1-1/2 in. wide face, installed perpendicular to the main runners, spaced 16 in. OC. Additional cross tees or channels used at 8 in. from each side of butted panel end joints. The cross tees or channels may be riveted or screw-attached to the wall angle or channel to facilitate the ceiling installation.

c. **Wall angles or channels** — Min 0.016 in. thick painted or galvanized steel angle with 1 in. legs or channel with a 1 by 1 1/2 by 1 in. profile, attached to walls at perimeter of ceiling with fasteners 16 in. OC. Used to support steel framing member ends and for screw-attachment of the gypsum panels.

**CGC INC** — Type DGL, RX

**USG INTERIORS LLC** — Type DGL, RX

**6C. Steel Framing Members\*** — (Not Shown) - As an alternate to Item 6 and 6A.

a. **Hat Channels** — Formed of No. 25 MSG galv steel, 2-9/16 in. or 2-23/32 in. wide by 7/8 in. deep, spaced 12 in. OC perpendicular to wood structural members. Channels secured to trusses as described in Item b. Ends of adjoining channels overlapped 6 in. and tied together with double strand of No. 18 AWG galv steel wire near each end of overlap.

b. **Steel Framing Members\*** — Used to attach furring channels (Item a) to trusses (Item 2). Clips spaced 12 in. OC, RSIC-1 and RSIC-1 (2.75) clips secured to consecutive trusses with No. 8 x 2-1/2 in. course drywall screw through the center grommet. RSIC-V and RSIC-V (2.75) clips secured to consecutive joists with No. 8 x 1-1/2 in. coarse drywall screw through the center hole. Furring channels are friction fitted into clips. RSIC-1 and RSIC-V clips for use with 2-9/16 in. wide furring channels. RSIC-1 (2.75) and RSIC-V (2.75) clips for use with 2-23/32 in. wide furring channels. Adjoining channels are overlapped as described in Item a. As an alternate, ends of adjoining channels may be overlapped 6 in. and secured together with two self-tapping No. 6 framing screws, min 7/16 in. long at the midpoint of the overlap, with one screw on each flange of the channel. Additional clips required to hold furring channel that supports the gypsum board butt joints, as described in Item 7.

**PAC INTERNATIONAL L L C** — Types RSIC-1, RSIC-V, RSIC-1 (2.75), RSIC-V (2.75).

**6D. Steel Framing Members\*** — (Optional, Not Shown) - As an alternate to Item 6 and 6A. Used as an alternate method to attach min. 1/2 in. deep resilient channels (Item 6) to wood trusses (Item 2). Resilient channels are friction fitted into clips, and then clips are secured to the bottom chord of each wood truss with a min. 1-3/4 in. long Type S bugle head steel screw through the center hole of the clip and the resilient channel flange. Adjoining resilient channels are overlapped 4 in. under trusses. The clip flange is opened slightly to accommodate the two overlapped channels. Additional clips required to hold resilient channel that supports the gypsum board butt joints, as described in Item 7.

**KEENE BUILDING PRODUCTS CO INC** — Type RC Assurance.

**6E. Alternate Steel Framing Members** — (Not Shown)\* — As an alternate to Item 6 and 6A., furring channels and Steel Framing Members as described below.

a. **Hat Channels** — Formed of No. 25 MSG galv steel, 2-5/8 in. wide by 7/8 in deep, spaced 12 in OC, perpendicular to trusses. Channels secured to joists as described in Item b.

b. **Steel Framing Members\*** — Used to attach furring channels (Item a) to the wood trusses (Item 2). Clips spaced at 48" OC and secured to the bottom of the trusses with one 2 in. Coarse Drywall Screw with 1 in. diam washer through the center hole. Furring channels are then friction fitted into clips. Ends of channels are overlapped 6" and tied together with double strand of No. 18 AWG galvanized steel wire. Additional clips are required to hold the Gypsum Butt joints as described in Item 7.

**STUDCO BUILDING SYSTEMS** — RESILMOUNT Sound Isolation Clips - Type A237 or A237R

**6F. Steel Framing Members\*** — (Optional, Not Shown) — As an alternate to Item 6 and 6A..

a. **Hat Channels** — Formed of No. 25 MSG galv steel, nominal 2-1/2 in. wide by 7/8 in. deep, spaced as indicated in Item 6, perpendicular to the trusses. Channels secured to Cold Rolled Channels at every intersection with a 3/4 in. TEK screw through each furring channel leg. Ends of adjoining channels overlapped 12 in. and fastened together with two double strand No. 18 SWG galv steel wire ties, one at each end of overlap, or with two 3/4 in. TEK screws in each leg of the overlap section. Two furring channels used at end joints of gypsum board (Item 7), each extending a min of 6 in. beyond both side edges of the board.

b. **Cold Rolled Channels** — 1-1/2 in. by 1/2 in., formed from No. 16 ga. galv steel, positioned vertically and parallel to trusses, friction-fitted into the channel caddy on the Steel Framing Members (Item 6Ed) and secured with two 3/4 in. TEK screws. Adjoining lengths of cold rolled channels lapped min. 12 in. and secured along bottom legs with four 3/4 in. TEK screws and wire-tied together with two double strand 18 SWG galv steel wire ties, one at each end of overlap.

c. **Blocking** — Where truss design does not permit direct, full contact of the hanger bracket, a piece of nominal 2 by 4 in. lumber (blocking), min. 12 in. long to permit full contact of the hanger bracket, to be secured vertically to the side of the trusses at the top and bottom of the blocking at each Steel Framing Member (Item 6Ed) location with 16d nails or minimum 2-1/2 in. screws.

d. **Steel Framing Members\*** — Spaced 48 in. OC. max along truss, and secured to the truss on alternating trusses with two, #10 x 1-1/2 in. screws through mounting holes on the hanger bracket.

**PAC INTERNATIONAL L L C** — Type RSIC-SI-CRC EZ Clip

**6G. Steel Framing Members\*** — (Not Shown) — As an alternate to Item 6 and 6A..

a. **Hat Channels** — Formed of No. 25 MSG galv steel, nominal 2-1/2 in. wide by 7/8 in. deep, spaced as indicated in Item 6, perpendicular to trusses and friction fit into Steel Framing Members (Item 6Fc). Ends of adjoining channels overlapped 6 in. and tied together with double strand of No. 18 SWG galv steel wire near each end of overlap or with two TEK screws along each leg of the 6 in. overlap. Two furring channels used at end joints of gypsum board (Item 7). Butt joint channels held in place by strong back channels placed upside down, on top of, and running perpendicular to primary furring channels, extending 6 in. longer than length of gypsum side joint. Strong back channels spaced maximum 48 in. OC. Strong back channels secured to every intersection of primary furring channels with four 7/16 in. pan head screws, two along each of the legs at intersections. Butt joint channels run perpendicular to strong back channels and shall be minimum 6 in. longer than length of joint, secured to strong back channels with 7/16 in. pan head screws, two along each of the legs at intersection with strong back channels.

b. **Blocking** — Where truss design does not permit direct, full contact of the hanger bracket, a piece of nominal 2 by 4 in. lumber (blocking), min. 12 in. long to permit full contact of the hanger bracket, to be secured vertically to the side of the trusses at the top and bottom of the blocking at each Steel Framing Member (Item 6Fc) location with 16d nails or minimum 2-1/2 in. screws.

c. **Steel Framing Members\*** — Used to attach furring channels (Item 6Fa) to trusses. Clips spaced 48 in. OC and secured along truss webs at each furring channel intersection with min. 3/4 in. long self-drilling #10 x 1-1/2 in. screws through each of the provided hole locations. Furring channels are friction fitted into clips.

**PAC INTERNATIONAL L L C** — Type RSIC-S1-1 Ultra

6H. **Steel Framing Members\*** — (Optional - Not Shown) — As an alternate to Item 6 and 6A. Used to attach resilient channels (Item 6) to trusses (Item 2). Clips spaced 48 in. OC and secured to trusses with one No. 8 x 2-1/2 in. coarse drywall screw through center grommet hole. Channels secured to clips with one #10 x 1/2 in. pan-head self-drilling screw. Ends of adjoining channels overlapped 6 in. and secured together with two #8 15 x 1/2 in. Philips Modified screws spaced 2-1/2 in. from the center of the overlap. Gypsum board butt joints require additional resilient channels spaced 1-1/2 in. from the butt joint on either side. One edge of the extra channels will extend to an adjacent truss where it is secured with a clip.

**KEENE BUILDING PRODUCTS CO INC** — Type RC+ Assurance Clip

6I. **Steel Framing Members\*** — (Optional, Not Shown) — As an alternate to Item 6 and 6A. Used as an alternate method to attach resilient channels to structural members. A resilient sound isolation accessory shall be used at each attachment point of the resilient channels and spaced max 24 in. O.C. Channel ends butted and centered under the structural members and attached with one accessory at each end. Additional accessories used to hold resilient channels that support the gypsum board end joints. The accessory envelops the mounting edge of the resilient channel. The accessory and resilient channel are fastened to the structural members with the screws supplied with the accessory and per the accessory manufacturer's installation instructions. Gypsum Board butt joints staggered minimum 24 in. OC and Gypsum Board screws spaced 8 in. OC (in lieu of 12 in.) when used.

**PAC INTERNATIONAL L L C** — Type RC-1 Boost

7. **Gypsum Board\*** — For use with Item 6 and alternates. Nom 5/8 in. thick, 48 in. wide gypsum panels. When resilient channels (Item 6) are used, gypsum panels installed with long dimension perpendicular to resilient channels. Gypsum panels secured with 1 in. long Type S bugle head steel



screws spaced 12 in. OC and located a min of 1/2 in. from side joints and 3 in. from end joints. When insulation (Items 5 or 5A) is applied over the resilient channel/gypsum panel ceiling membrane the screw spacing shall be reduced to 8 in. OC. End joints secured to both resilient channels as shown in end joint detail. When Steel Framing Members (Item 6B) are used, gypsum panels installed with long dimension perpendicular to cross tees with side joints centered along main runners and end joints centered along cross tees. Panels fastened to cross tees with 1 in. long Type S bugle-head screws spaced 8 in. OC in the field and along end joints. Panels fastened to main runners with 1 in. long Type S bugle-head screws spaced midway between cross tees. Screws along sides and ends of panels spaced 3/8 to 1/2 in. from board edge. End joints of panels shall be staggered with spacing between joints on adjacent panels not less than 2 ft OC. When Steel Framing Members (Item 6C) are used, gypsum panels installed with long dimensions perpendicular to furring channels. Panels attached to the furring channels using 1 in. long Type S bugle-head steel screws spaced 8 in. OC along butted end joints and in the field of the panel. Butted end joints shall be staggered min. 2 ft within the assembly, and occur midway between the continuous furring channels. Each end of each gypsum panel shall be supported by a single length of furring channel equal to the width of the gypsum panel plus 6 in. on each end. The two support furring channels shall be spaced approximately 3-1/2 in. OC, and be attached to underside of the truss with one clip at each end of the channel.

When **Steel Framing Members** (Item 6E) are used, one layer of nom 5/8 in. thick, 4 ft wide gypsum board is installed with long dimensions perpendicular to furring channels. Gypsum board secured to furring channels with nom 1 in. long Type S bugle-head steel screws spaced 8 in. OC in the field of the board. Gypsum board butted end joints shall be staggered minimum 48 in. and centered over main furring channels. At the gypsum board butt joints, each end of each gypsum board shall be supported by a single length of furring channel equal to the width of the gypsum board plus 3 in. on each end. The two support furring channels shall be spaced approximately 3 in. in from joint. Screw spacing along the gypsum board butt joint and along both additional channels shall be 8 in. OC. Additional screws shall be placed in the adjacent section of gypsum board into the aforementioned 3 in. extension of the extra butt joint channels as well as into the main channel that runs between. Butt joint furring channels shall be attached with one RESILMOUNT Sound Isolation Clip at each end of the channel.

When **Steel Framing Members** (Item 6F) are used, nom 5/8 in. thick, 4 ft wide gypsum board, installed as described in Item 7. Adjacent butt joints staggered minimum 48 in. OC.

When **Steel Framing Members** (Item 6G) are used, nom 5/8 in. thick, 4 ft wide gypsum board, installed as described in Item 7. Butt joints staggered minimum 24 in. OC.

**CGC INC** — Types C, IP-X2, IPC-AR

**CERTAINTEED GYPSUM INC** — Type LGFC-C/A

**UNITED STATES GYPSUM CO** — Types C, IP-X2, IPC-AR

**USG MEXICO S A DE C V** — Types C, IP-X2, IPC-AR

7A . **Gypsum Board\*** — For use with Item 6A and alternates. Nom 5/8 in. thick, 48 in. wide gypsum panels installed as described in Item 7.

**American Gypsum Co.** – Type AG-C

8. **Finishing System — (Not Shown)** — Vinyl, dry or premixed joint compound, applied in two coats to joints and screw-heads. Nom 2 in. wide paper tape embedded in first layer of compound over all joints. As an alternate, nom 3/32 in. thick veneer plaster may be applied to the entire surface of gypsum board.

**\* Indicates such products shall bear the UL or cUL Certification Mark for jurisdictions employing the UL or cUL Certification (such as Canada), respectively.**

Last Updated on 2023-04-04