

# Design No. L579

November 1, 2022

**Unrestrained Assembly Rating — 1 Hr.  
Finish Rating — 23 Min (See Items 5 or 5A)**

**This design was evaluated using a load design method other than the Limit States Design Method (e.g., Working Stress Design Method). For jurisdictions employing the Limit States Design Method, such as Canada, a load restriction factor shall be used — See Guide [BXUV](#) or [BXUV7](#)**

**\* Indicates such products shall bear the UL or cUL Certification Mark for jurisdictions employing the UL or cUL Certification (such as Canada), respectively.**

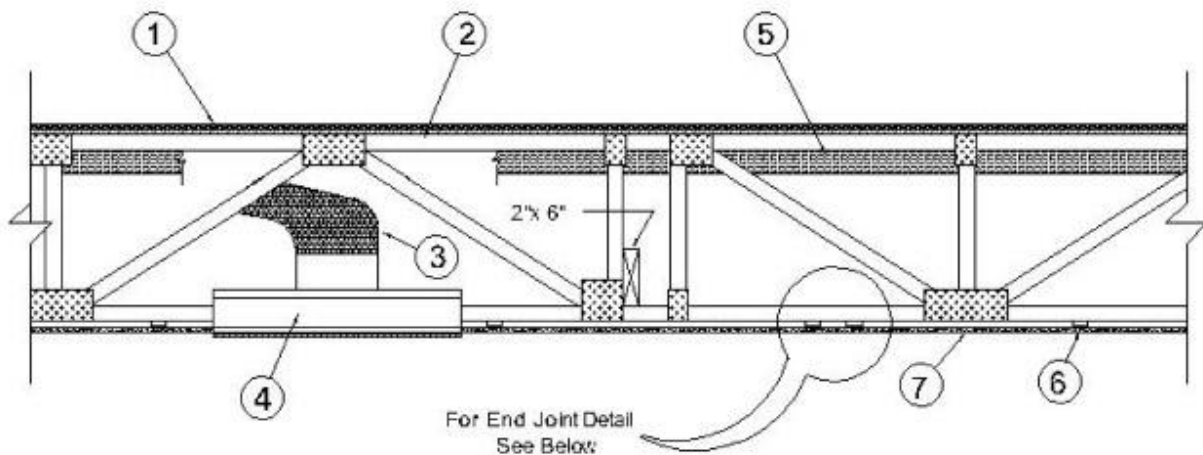

1. **Flooring System** — The flooring system shall consist of one of the following:

### **System No. 1**

**Subflooring** — Min 23/32 in. thick T & G wood structural panels installed perpendicular to trusses with joints staggered 4 ft. Plywood or non-veneer APA rated panels secured to trusses with construction adhesive and No. 6d ring shank nails spaced 12 in. OC along each truss. Staples having equal or greater withdrawal and lateral resistance strength may be substituted for the 6d nails.

**Vapor Barrier** (Optional) — Nom 0.030 in. thick commercial asphalt saturated felt.

**Floor Topping Mixture\*** — Min 3/4 in. thickness of floor topping mixture having a minimum compressive strength of 1500 psi. Refer to manufacturer's instructions accompanying the material for specific mix design.

**MAXXON CORP** — Type Maxxon Standard and Maxxon High Strength

**Floor Mat Materials\*** (Optional) - Floor mat material loose laid over the subfloor. Refer to manufacturer's instructions regarding the minimum thickness of floor topping over each floor mat material.

**MAXXON CORP** — Type Encapsulated Sound Mat.

**Floor Mat Reinforcement** — (Optional) Refer to manufacturer's instructions regarding minimum thickness of floor topping for use with floor mat reinforcement.

**Metal Lath** — (Optional) 3/8 in. expanded galvanized steel diamond mesh, 3.4 lbs/sq yd loose laid over the floor mat material.

**Fiber Glass Reinforcement** — (Optional) - 0.015 in. thick PVC coated non-woven fiberglass mesh, 0.368 lbs./sq. yd loose laid over the floor mat material.

### **System No. 2**

**Subflooring** — Min 23/32 in. thick T & G wood structural panels installed perpendicular to trusses with joints staggered 4 ft. Plywood or non-veneer APA rated panels secured to trusses with construction adhesive and No. 6d ring shank nails spaced 12 in. OC along each truss. Staples having equal or greater withdrawal and lateral resistance strength may be substituted for the 6d nails.

**Vapor Barrier** — (Optional) Nom 0.030 in. thick commercial asphalt saturated felt.

**Floor Topping Mixture\*** — Min 3/4 in. thickness of floor topping mixture having a minimum compressive strength of 1500 psi. Refer to manufacturer's instructions accompanying the material for specific mix design.

**FORMULATED MATERIALS LLC** — Types FR-25, FR-30, and SiteMix

**Floor Mat Materials\*** — (Optional) Floor mat material loose laid over the subfloor. Refer to manufacturer's instructions regarding the minimum thickness of floor topping over each floor mat material.

**FORMULATED MATERIALS LLC** — Types M1, M2, M3, Elite, Duo, R1, and R2

### **System No. 3**

**Subflooring** — Min 23/32 in. thick T&G wood structural panels, min grade "Underlayment" or "Single-Floor". Face grain of plywood or strength axis of panels to be perpendicular to the trusses with end joints staggered 4 ft. Panels secured to trusses with construction adhesive and No. 6d ringed shank nails spaced 12 in. OC along each truss. Staples having equal or greater withdrawal and lateral resistance strength may be substituted for the 6d nails.

**Gypsum Board\*** — One layer of nom 5/8 in. thick, 4 ft wide gypsum board, installed with long dimension perpendicular to joists. Gypsum board secured with 1 in. long No. 6 Type W bugle head

steel screws spaced 12 in. OC and located a min of 1-1/2 in. from side and end joints. The joints of the gypsum board are to be staggered a minimum of 12 inches from the joints of the subfloor.

**GEORGIA-PACIFIC GYPSUM L L C** — Type DS

**Floor Mat Materials\***— (As an alternate to the single layer gypsum board) - Floor mat material loose laid over the subfloor.

**MAXXON CORP** — Type Encapsulated Sound Mat.

**Gypsum Board\*** — (For use when floor mat is used) Two layers of nom 5/8 in. thick, 4 ft wide gypsum board, installed with long dimension perpendicular to joists on top of the floor mat material. Gypsum board secured to each other with 1 in. long No. 6 Type G bugle head steel screws spaced 12 in. OC and located a min of 1-1/2 in. from side and end joints. The joints of the gypsum board are to be staggered a minimum of 12 inches in between layers and from the joints of the subfloor.

**GEORGIA-PACIFIC GYPSUM L L C** — Type DS

#### **System No. 4**

**Subflooring** — Min 23/32 in. thick T & G wood structural panels installed perpendicular to trusses with joints staggered 4 ft. Plywood or non-veneer APA rated panels secured to trusses with construction adhesive and No. 6d ring shank nails spaced 12 in. OC along each truss. Staples having equal or greater withdrawal and lateral resistance strength may be substituted for the 6d nails.

**Vapor Barrier** — (Optional) - Nom 0.010 in. thick commercial asphalt saturated felt.

**Finish Flooring - Floor Topping Mixture\*** — Min 3/4 in. thickness of floor topping mixture having a minimum compressive strength of 1800 psi. Refer to manufacturer's instructions accompanying the material for specific mix design.

**UNITED STATES GYPSUM CO** — Types LRK, HSLRK, CSD

**USG MEXICO S A DE C V** — Types LRK, HSLRK, CSD

**Floor Mat Materials\*** — (Optional) - Floor mat material loose laid over the subfloor. Refer to manufacturer's instructions regarding the minimum thickness of floor topping over each floor mat material.

**UNITED STATES GYPSUM CO** — Types SAM, LEVELROCK® Brand Sound Reduction Board, LEVELROCK® Brand Floor Underlayment SRM-25

#### **System No. 5**

**Sub-flooring**— Min 19/32 in. thick wood structural panels, min grade "C-D" or "Sheathing". Face grain of plywood or strength axis of panel to be perpendicular to joists with joints staggered.

**Floor Mat Materials\*** — (Optional) Floor mat material nom 1/8 in. (3mm) thick loose laid over the subfloor. Floor topping thickness shall be a min of 3/4 in. (19mm)

**HACKER INDUSTRIES INC** — FIRM-FILL SCM 125

**Alternate Floor Mat Materials** — (Optional) Floor mat material nom 1/4 in. (6mm) thick loose laid over the subfloor. Floor topping thickness shall be a min of 1 in. (25mm)

**HACKER INDUSTRIES INC** — Type FIRM-FILL SCM 250

**Alternate Floor Mat Materials** — (Optional) Floor mat material nom 3/8 in. (10 mm) thick loose laid over the subfloor. Floor topping thickness shall be a min of 1-1/4 in. (32mm)

**HACKER INDUSTRIES INC** — FIRM-FILL SCM 400

**Alternate Floor Mat Materials** — (Optional) Floor mat material nom 3/4 in. (19mm) thick loose laid over the subfloor. Floor topping thickness shall be a min of 1-1/2 in. (38mm)

**HACKER INDUSTRIES INC** — Type FIRM-FILL SCM 750

**Alternate Floor Mat Materials** — (Optional) Floor mat material nom 5/64 in. (2 mm) thick adhered to subfloor with Hacker Floor Primer. Primer to be applied to the surface of the mat prior to the placement of floor-topping mixture. Floor topping thickness a min 1 in. over the floor mat.

**HACKER INDUSTRIES INC** — Type Hacker Sound-Mat.(HSM1.02)

**Alternate Floor Mat Materials** — (Optional) Floor mat material nom 1/4 in. (6mm) thick adhered to subfloor with Hacker Floor Primer. Primer to be applied to the surface of the mat prior to the placement of a min 1-1/4 in. (32mm) of floor-topping mixture.

**HACKER INDUSTRIES INC** — Type Hacker Sound-Mat II. (HSM2.06)

**Metal Lath** — (Optional) For use with 3/8 in. (10 mm) or greater floor mat materials, 3/8 in. expanded steel diamond mesh, 3.4 lbs/sq yd placed over the floor mat material. Hacker Floor Primer to be applied prior to the placement of the metal lath. When metal lath is used, floor topping thickness a nom 1-1/4 in. over the floor mat.

**Finish Flooring - Floor Topping Mixture\*** — Min 3/4 in. thickness of floor topping mixture having a min compressive strength of 1100 psi. Mixture shall consist of 6.8 gal of water to 80 lbs of floor topping mixture to 1.9 cu ft of sand.

**HACKER INDUSTRIES INC** — Firm-Fill Gypsum Concrete, Firm-Fill 2010, Firm-Fill 3310, Firm-Fill 4010, Firm-Fill High Strength, Gyp-Span Radiant

### **System No. 6**

**Subflooring** — Min 23/32 in. thick T & G wood structural panels installed perpendicular to trusses with joints staggered 4 ft. Plywood or non-veneer APA rated panels secured to trusses with construction adhesive and No. 6d ring shank nails spaced 12 in. OC along each truss. Staples having equal or greater withdrawal and lateral resistance strength may be substituted for the 6d nails.

**Vapor Barrier** — (Optional) — Commercial asphalt saturated felt, 0.030 in. thick.

**Vapor Barrier** — (Optional) — Nom 0.010 in. thick commercial rosin-sized building paper.

**Finish Flooring\*** — Min 3/4 in. thickness of any Floor Topping Mixture bearing the UL Classification Marking as to Fire Resistance. See Floor- and Roof-Topping Mixtures (CCOX) category for names of Classified Companies. Refer to the manufacturer's instructions accompanying the material and/or contact the manufacturer's technical support for specific mix design and minimum thickness recommended for use with eligible floor mat(s).

**Floor Mat Materials\*** — (Optional) — Nom. 1/4 in. thick loose laid over the subfloor. Floor topping thickness shall be a minimum of 3/4 in.

**KEENE BUILDING PRODUCTS CO INC** — Types Quiet Qurl 55/025 and Quiet Qurl 55/025 N

**Alternate Floor Mat Materials\*** — (Optional) — Floor mat material Nom. 3/8 in. thick loose laid over the subfloor. Floor topping thickness shall be a minimum of 1 in.

**KEENE BUILDING PRODUCTS CO INC** — Types Quiet Qurl 60/040 and Quiet Qurl 60/040 N

**Alternate Floor Mat Materials\*** — (Optional) — Floor mat material Nom. 3/4 in. thick loose laid over the subfloor. Floor topping thickness shall be a minimum of 1-1/2 in.

**KEENE BUILDING PRODUCTS CO INC** — Types Quiet Qurl 65/075, Quiet Qurl 65/075 N

**Alternate Floor Mat Materials\*** — (Optional) — Floor mat material Nom. 1/8 in. thick loose laid over the subfloor. Floor topping thickness shall be a minimum of 3/4 in.

**KEENE BUILDING PRODUCTS CO INC** — Types Quiet Qurl 52/013 and Quiet Qurl 52/013 N

**Alternate Floor Mat Materials\*** — (Optional) — Floor mat material Nom. 1/4 in. entangled net core with a compressible fabric attached to the bottom loose laid over the subfloor. Floor topping thickness shall be a minimum of 1 in.

**KEENE BUILDING PRODUCTS CO INC** — Types Quiet Qurl 55/025 MT and Quiet Qurl 55/025 N MT

### **System No. 7**

**Subflooring** — Min 23/32 in. thick T & G wood structural panels installed perpendicular to trusses with joints staggered 4 ft. Plywood or non-veneer APA rated panels secured to trusses with construction adhesive and No. 6d ring shank nails spaced 12 in. OC along each truss. Staples having equal or greater withdrawal and lateral resistance strength may be substituted for the 6d nails.

**Vapor Barrier** — (Optional) — Nom 0.030 in. thick commercial asphalt saturated felt.

**Finish Flooring — Floor Topping Mixture\*** — Min 3/4 in. thickness of floor topping mixture, having a min compressive strength of 1000 psi. Refer to manufacturer's instructions accompanying the material for specific mix design.

**DEPENDABLE LLC** — Types GSL M3.4, GSL K2.6 and GSL RH

**Floor Mat Materials\*** — (Optional) — Nom. 1/4 in. thick loose laid over the subfloor. Floor topping thickness shall be a minimum of 3/4 in.

**KEENE BUILDING PRODUCTS CO INC** — Types Quiet Qurl 55/025 and Quiet Qurl 55/025 N

**Alternate Floor Mat Materials\*** — (Optional) — Floor mat material Nom. 3/8 in. thick loose laid over the subfloor. Floor topping thickness shall be a minimum of 1 in.

**KEENE BUILDING PRODUCTS CO INC** — Types Quiet Qurl 60/040 and Quiet Qurl 60/040 N

**Alternate Floor Mat Materials\*** — (Optional) — Floor mat material Nom. 3/4 in. thick loose laid over the subfloor. Floor topping thickness shall be a minimum of 1-1/2 in.

**KEENE BUILDING PRODUCTS CO INC** — Types Quiet Qurl 65/075, Quiet Qurl 65/075 N

**Alternate Floor Mat Materials\*** — (Optional) — Floor mat material Nom. 1/8 in. thick loose laid over the subfloor. Floor topping thickness shall be a minimum of 3/4 in.

**KEENE BUILDING PRODUCTS CO INC** — Types Quiet Qurl 52/013 and Quiet Qurl 52/013 N

**Alternate Floor Mat Materials\*** — (Optional) — Floor mat material Nom. 1/4 in. entangled net core with a compressible fabric attached to the bottom loose laid over the subfloor. Floor topping thickness shall be a minimum of 1 in.

**KEENE BUILDING PRODUCTS CO INC** — Types Quiet Qurl 55/025 MT and Quiet Qurl 55/025 N MT

### **System No. 8**

**Subflooring** — Min 23/32 in. thick T & G wood structural panels installed perpendicular to trusses with joints staggered 4 ft. Plywood or non-veneer APA rated panels secured to trusses with construction adhesive and No. 6d ring shank nails spaced 12 in. OC along each truss. Staples having equal or greater withdrawal and lateral resistance strength may be substituted for the 6d nails.

**Finish Flooring - Floor Topping Mixture\*** — Min 1 in. thickness of floor topping mixture having a min compressive strength of 4500 psi. Refer to manufacturer's instructions accompanying the material for specific mix design.

**SIKA DEUTSCHLAND GMBH** — Type SCHONOX AP Rapid Plus

### **System No. 9**

**Subflooring** — Min 23/32 in. thick T & G wood structural panels installed perpendicular to trusses with joints staggered 4 ft. Plywood or non-veneer APA rated panels secured to trusses with construction adhesive and No. 6d ring shank nails spaced 12 in. OC along each truss. Staples having equal or greater withdrawal and lateral resistance strength may be substituted for the 6d nails.

**Vapor Barrier** — (Optional) - Commercial asphalt saturated felt, 0.030 in. thick.

**Vapor Barrier** — (Optional) - Nom 0.010 in. thick commercial rosin-sized building paper.

**Finish Flooring - Floor Topping Mixture\*** — Min 3/4 in. thickness of any Floor Topping Mixture bearing the UL Classification Marking as to Fire Resistance. See Floor- and Roof-Topping Mixtures (CCOX) category for names of Classified Companies. Refer to the manufacturer's instructions

accompanying the material and/or contact the manufacturer's technical support for specific mix design and minimum thickness recommended for use with eligible floor mat(s).

**Floor Mat Materials\*** — (Optional, Not Shown) - Floor mat material loose laid over the subfloor. Refer to manufacturer's instructions regarding the minimum thickness of floor topping over each floor mat material.

**LOW & BONAR INC** — EnkaSonic® by Colbond a member of the Low & Bonar group Types 125, 250, 250 Plus, 400, 400 Plus, 750 and 750 Plus.

**Floor Mat Reinforcement** — (Optional) - Refer to manufacturer's instructions regarding minimum thickness of floor topping for use with floor mat reinforcement.

**Metal Lath** — (Optional) — Expanded steel diamond mesh, 2.5 lb / sq yd loose laid over floor mat material.

**Fiberglass Mesh Reinforcement** — (Optional) — Coated non-woven glass fiber mesh grid loose laid over floor mat material.

2. **Trusses** — Parallel chord trusses, spaced a max of 24 in. OC, fabricated from nom 2 by 4 lumber, with lumber oriented vertically or horizontally. Min truss depth is 12 in. Truss members secured together with min 0.0356 in. thick galvanized steel plates. Plates have 5/16 in. long teeth projecting perpendicular to the plane of the plate. The teeth are in pairs facing each other (made by the same punch), forming a split tooth type plate. Each tool has a chisel point on its outside edge. These points are diagonally opposite each other for each pair. The top half of each tooth has a twist for stiffness. The pairs are repeated on approx. 7/8 in. centers with four rows of teeth per inch of plate width.

3. **Air Duct\*** — Any UL Class 0 or Class 1 flexible air duct installed in accordance with the instructions provided by the damper manufacturer.

4. **Damper\*** — For use with min 18 in. deep trusses. Max nom 20 in. long by 18 in. wide by 2-1/8 in. high, fabricated from galvanized steel. Plenum box max size nom 21 in. long by 18 in. wide by 16 in. high fabricated from either galvanized steel or Classified Air Duct Materials bearing the UL Classification Marking for Class 0 or Class 1 rigid air duct material. Installed in accordance with the instructions provided by the manufacturer. Max damper openings not to exceed 180 sq in. per 100 sq ft of ceiling area.

**NAILOR INDUSTRIES INC** — Types 0755, 0755A, 0756, 0756D, 0757, 0757D, 0757FP, 0757DFP, 0758, 0759, 0760, 0761, 0762, 0763, CRD5, CRD5D, CRD6, CRD6D, CRD6FP, CRD6DFP

**SAFE AIR DOWCO** — 0455, 0455A, 0456, 0456D, 0457, 0457D, 0457-DB, 0457-CB, 0463-FB, 0457-EB, 0463-GB, 0463

5. **Batts and Blankets\*** — (Optional) - Glass fiber or mineral wool insulation bearing the UL Classification Marking as to Surface Burning Characteristics and/or Fire Resistance. When the resilient channels (Item 6) are spaced 16 in. OC, the insulation shall be a max of 3-1/2 in. thick, and shall be secured against the subflooring with staples at 12 in. OC or held suspended in the concealed space with 0.090 in. diam galv steel wires attached to the wood trusses at 12 in. OC. When the resilient channels are spaced a max of 12 in. OC or when the Steel Framing Members (Item 6A) are used, there is no limit in the overall thickness of insulation, and the insulation can be secured against the

subflooring, held suspended in the concealed space or draped over the resilient channels (or Steel Framing Members) and gypsum panel membrane. The finished rating has only been determined when the insulation is secured to the subflooring.

5A. **Loose Fill Material\*** — (Optional) - As an alternate to Item 5, when the resilient channels (Item 6) are spaced a maximum of 12 in. OC, or when the Steel Framing Members (Item 6A) are used - Any loose fill material bearing the UL Classification Marking for Surface Burning Characteristics. There is no limit in the overall thickness of insulation. The finished rating when loose fill material is used has not been determined.

6. **Resilient Channels** — Formed from min 0.020 in. thick galv steel, 1/2 in. deep by 2-3/8 in. wide at the base and 1-3/8 in. wide at the face, spaced 16 in. OC perpendicular to trusses. When insulation (Items 5 or 5A) is applied over the resilient channel/gypsum panel ceiling membrane, the resilient channel spacing shall be reduced to 12 in. OC. Channels secured to each truss with 1-1/4 in. long Type S bugle head steel screws. Channels overlapped 4 in. at splices. Two channels, spaced 6 in. OC, oriented opposite each gypsum panel end joint as shown in the above illustration. Additional channels shall extend min 6 in. beyond each side edge of panel.

6A. **Steel Framing Members\*** — (Not Shown) — As an alternate to Item 6.

a. **Main Runners** — Nom 10 or 12 ft long, 15/16 in. or 1-1/2 in. wide face, spaced 4 ft OC perpendicular to trusses. Main runners hung a min of 2 in. from bottom chord of trusses with 12 SWG galv steel wire. Wires spaced max 48 in. OC.

b. **Cross tees or channels** — Cross tees, nom 4 ft long, 15/16 in. or 1-1/2 in. wide face, or cross channels, nom 4 ft long, 1-1/2 in. wide face, installed perpendicular to the main runners, spaced 16 in. OC. Additional cross tees or channels used at 8 in. from each side of butted panel end joints. The cross tees or channels may be riveted or screw-attached to the wall angle or channel to facilitate the ceiling installation.

c. **Wall angles or channels** — Min 0.016 in. thick painted or galvanized steel angle with 1 in. legs or channel with a 1 by 1 1/2 by 1 in. profile, attached to walls at perimeter of ceiling with fasteners 16 in. OC. Used to support steel framing member ends and for screw-attachment of the gypsum panels.

**CGC INC** — Type DGL, RX

**USG INTERIORS LLC** — Type DGL, RX

6B. **Steel Framing Members\*** — (Not Shown) - As an alternate to Items 6 and 6A.

a. **Furring Channels** — Formed of No. 25 MSG galv steel, 2-9/16 in. or 2-23/32 in. wide by 7/8 in. deep, spaced 12 in. OC perpendicular to wood structural members. Channels secured to trusses as described in Item b. Ends of adjoining channels overlapped 6 in. and tied together with double strand of No. 18 AWG galv steel wire near each end of overlap.

b. **Steel Framing Members\*** — Used to attach furring channels (Item a) to trusses (Item 2). RSIC-1 and RSIC-1 (2.75) clips spaced 48 in. OC, and secured to bottom of trusses with No. 8 x 2-1/2 in. course drywall screw through the center grommet. RSIC-V and RSIC-V (2.75) clips spaced 12 in. OC, and secured to consecutive trusses with No. 8 x 1-1/2 in. course drywall screw through the center hole. Furring channels are friction fitted into clips. RSIC-1 and RSIC-V clips for use with 2-9/16 in.



wide furring channels. RSIC-1 (2.75) and RSIC-V (2.75) clips for use with 2-23/32 in. wide furring channels. Adjoining channels are overlapped as described in Item a. As an alternate, ends of adjoining channels may be overlapped 6 in. and secured together with two self-tapping No. 6 framing screws, min 7/16 in. long at the midpoint of the overlap, with one screw on each flange of the channel. Additional clips required to hold furring channel that supports the gypsum board butt joints, as described in Item 7.

**PAC INTERNATIONAL L L C** — Types RSIC-1, RSIC-V, RSIC-1 (2.75), RSIC-V (2.75).

**6C. Steel Framing Members\*** — (Not Shown) - As an alternate to Items 6, 6A and 6B.

a. **Furring Channels** — Formed of No. 25 MSG galv steel, 2-3/8 in. wide by 7/8 in. deep, spaced 12 in. OC perpendicular to wood structural members. Channels secured to trusses as described in Item b.

b. Ends of adjoining channels overlapped 6 in. and tied together with double strand of No. 18 AWG galv steel wire near each end of overlap.

b. **Steel Framing Members\*** — Used to attach furring channels (Item a) to trusses (Item 2). GenieClips spaced 48 in. OC, and secured to bottom of trusses with No. 8 x 2-1/2 in. course drywall screw through the center grommet. When insulation, Item 5 is applied over the resilient channel/gypsum panel ceiling membrane, the clip spacing shall be reduced to 12 in. OC and secured to consecutive trusses. Furring channels are friction fitted into clips. Adjoining channels are overlapped as described in Item a. As an alternate, ends of adjoining channels may be overlapped 6 in. and secured together with two self-tapping No. 6 framing screws, min 7/16 in. long at the midpoint of the overlap, with one screw on each flange of the channel. Additional clips required to hold furring channel that supports the gypsum board butt joints, as described in Item 7. Not evaluated for use with Item 5A or when insulation is draped over Furring Channels.

**PLITEQ INC** — Type GENIECLIP

**6D. Alternate Steel Framing Members\*** — (Not Shown) As an alternate to items 6-6C, furring channels and Steel Framing Members as described below.

a. **Furring Channels** — Formed of No. 25 MSG galv steel, 2-5/8 in. wide by 7/8 in deep, spaced 12 in OC, perpendicular to trusses. Channels secured to trusses as described in Item b.

b. **Steel Framing Members\*** — Used to attach furring channels (Item a) to the wood trusses (Item 2). Clips spaced at 48" OC and secured to the bottom of the trusses with one 2 in. Coarse Drywall Screw with 1 in. diam washer through the center hole. Furring channels are then friction fitted into clips. Ends of channels are overlapped 6" and tied together with double strand of No. 18 AWG galvanized steel wire. Additional clips are required to hold the Gypsum Butt joints as described in Item 7.

**STUDCO BUILDING SYSTEMS** — RESILMOUNT Sound Isolation Clips - Type A237 or A237R

**6E. Steel Framing Members\*** — (Optional, Not Shown) — As an alternate to Item 6.

a. **Furring Channels** — Formed of No. 25 MSG galv steel, nominal 2-1/2 in. wide by 7/8 in. deep, spaced as indicated in Item 6, perpendicular to the trusses. Channels secured to Cold Rolled Channels at every intersection with a 3/4 in. TEK screw through each furring channel leg. Ends of adjoining channels overlapped 12 in. and fastened together with two double strand No. 18 SWG galv steel wire ties, one at each end of overlap, or with two 3/4 in. TEK screws in each leg of the overlap section. Two furring channels used at end joints of gypsum board (Item 7), each extending a min of 6 in. beyond both side edges of the board.

b. **Cold Rolled Channels** — 1-1/2 in. by 1/2 in., formed from No. 16 ga. galv steel, positioned vertically and parallel to trusses, friction-fitted into the channel caddy on the Steel Framing Members (Item 6Ed) and secured with two 3/4 in. TEK screws. Adjoining lengths of cold rolled channels lapped min. 12 in. and secured along bottom legs with four 3/4 in. TEK screws and wire-tied together with two double strand 18 SWG galv steel wire ties, one at each end of overlap.

c. **Blocking** — Where truss design does not permit direct, full contact of the hanger bracket, a piece of nominal 2 by 4 in. lumber (blocking), min. 12 in. long to permit full contact of the hanger bracket, to be secured vertically to the side of the trusses at the top and bottom of the blocking at each Steel Framing Member (Item 6Ed) location with 16d nails or minimum 2-1/2 in. screws.

d. **Steel Framing Members\*** — Spaced 48 in. OC. max along truss, and secured to the truss on alternating trusses with two, #10 x 1-1/2 in. screws through mounting holes on the hanger bracket.

**PAC INTERNATIONAL L L C** — Type RSIC-SI-CRC EZ Clip

6F. **Steel Framing Members\*** — (Not Shown) — As an alternate to Item 6.

a. **Furring Channels** — Formed of No. 25 MSG galv steel, nominal 2-1/2 in. wide by 7/8 in. deep, spaced as indicated in Item 6, perpendicular to trusses and friction fit into Steel Framing Members (Item 6Fc). Ends of adjoining channels overlapped 6 in. and tied together with double strand of No. 18 SWG galv steel wire near each end of overlap or with two TEK screws along each leg of the 6 in. overlap. Two furring channels used at end joints of gypsum board (Item 7). Butt joint channels held in place by strong back channels placed upside down, on top of, and running perpendicular to primary furring channels, extending 6 in. longer than length of gypsum side joint. Strong back channels spaced maximum 48 in. OC. Strong back channels secured to every intersection of primary furring channels with four 7/16 in. pan head screws, two along each of the legs at intersections. Butt joint channels run perpendicular to strong back channels and shall be minimum 6 in. longer than length of joint, secured to strong back channels with 7/16 in. pan head screws, two along each of the legs at intersection with strong back channels.

b. **Blocking** — Where truss design does not permit direct, full contact of the hanger bracket, a piece of nominal 2 by 4 in. lumber (blocking), min. 12 in. long to permit full contact of the hanger bracket, to be secured vertically to the side of the trusses at the top and bottom of the blocking at each Steel Framing Member (Item 6Fc) location with 16d nails or minimum 2-1/2 in. screws.

c. **Steel Framing Members\*** — Used to attach furring channels (Item 6Fa) to trusses. Clips spaced 48 in. OC and secured along truss webs at each furring channel intersection with min. 3/4 in. long self-drilling #10 x 1-1/2 in. screws through each of the provided hole locations. Furring channels are friction fitted into clips.

**PAC INTERNATIONAL L L C** — Type RSIC-S1-1 Ultra

6G. **Steel Framing Members\*** — (Optional - Not Shown) — Used to attach resilient channels (Item 6) to trusses (Item 2). Clips spaced 48 in. OC and secured to trusses with one No. 8 x 2-1/2 in. coarse drywall screw through center grommet hole. Channels secured to clips with one #10 x 1/2 in. pan-head self-drilling screw. Ends of adjoining channels overlapped 6 in. and secured together with two #8 15 x 1/2 in. Philips Modified screws spaced 2-1/2 in. from the center of the overlap. Gypsum board butt joints require additional resilient channels spaced 1-1/2 in. from the butt joint on either side. One edge of the extra channels will extend to an adjacent truss where it is secured with a clip.

**KEENE BUILDING PRODUCTS CO INC** — Type RC+ Assurance Clip

**6H. Steel Framing Members\*** — (Optional, Not Shown) — Used as an alternate method to attach resilient channels to structural members. A resilient sound isolation accessory shall be used at each attachment point of the resilient channels and spaced max 24 in. O.C. Channel ends butted and centered under the structural members and attached with one accessory at each end. Additional accessories used to hold resilient channels that support the gypsum board end joints. The accessory envelops the mounting edge of the resilient channel. The accessory and resilient channel are fastened to the structural members with the screws supplied with the accessory and per the accessory manufacturer's installation instructions. Gypsum Board butt joints staggered minimum 24 in. OC and Gypsum Board screws spaced 8 in. OC when used.

**PAC INTERNATIONAL L L C** — Type RC-1 Boost

**6I. Furring Channels** — For use with **American Gypsum Co. Type AG-C gypsum board only**. Resilient channels min 0.020 in. thick galv steel, 1/2 in. deep by 2-3/8 in. wide at the base and 1-3/8 in. wide at the face, spaced 16 in. OC, installed perpendicular to trusses. When insulation material, Item 5 or 5A, is applied over the resilient channel/gypsum board ceiling membrane, the spacing may remain at 16 in. OC. Channels secured to each truss with 1-1/4 in. long Type S steel screws. Channels overlapped 4 in. at splices. Channels oriented opposite at gypsum board butt joints (spaced 6 in. OC) as shown in the above illustration.

**7. Gypsum Board\*** — Nom 5/8 in. thick, 48 in. wide gypsum panels. When resilient channels (Item 6) are used, gypsum panels installed with long dimension perpendicular to resilient channels. Gypsum panels secured with 1 in. long Type S bugle head steel screws spaced 12 in. OC and located a min of 1/2 in. from side joints and 3 in. from end joints. When insulation (Items 5 or 5A) is applied over the resilient channel/gypsum panel ceiling membrane the screw spacing shall be reduced to 8 in. OC. End joints secured to both resilient channels as shown in end joint detail. When Steel Framing Members (Item 6A) are used, gypsum panels installed with long dimension perpendicular to cross tees with side joints centered along main runners and end joints centered along cross tees. Panels fastened to cross tees with 1 in. long Type S bugle-head screws spaced 8 in. OC in the field and along end joints. Panels fastened to main runners with 1 in. long Type S bugle-head screws spaced midway between cross tees. Screws along sides and ends of panels spaced 3/8 to 1/2 in. from board edge. End joints of panels shall be staggered with spacing between joints on adjacent panels not less than 2 ft OC. When Steel Framing Members (Item 6B, 6C) are used, gypsum panels installed with long dimensions perpendicular to furring channels. Panels attached to the furring channels using 1 in. long Type S bugle-head steel screws spaced 8 in. OC along butted end joints and in the field of the panel. Butted end joints shall be staggered min. 2 ft within the assembly, and occur midway between the continuous furring channels. Each end of each gypsum panel shall be supported by a single length of furring channel equal to the width of the gypsum panel plus 6 in. on each end. The two support furring channels shall be spaced approximately 3-1/2 in. OC, and be attached to underside of the truss with one clip at each end of the channel. When **Steel Framing Members** (Item 6D) are used, one layer of nom 5/8 in. thick, 4 ft wide gypsum board is installed with long dimensions perpendicular to furring channels. Gypsum board secured to furring channels with nom 1 in. long Type S bugle-head steel screws spaced 8 in. OC in the field of the board. Gypsum board butted end joints shall be staggered minimum 48 in. and centered over main furring channels. At the gypsum board butt joints, each end of each gypsum board shall be supported by a single length of furring channel equal to the width of the gypsum board plus 3 in. on each end. The two support furring channels shall be spaced approximately 3 in. in from joint. Screw spacing along the gypsum board butt joint and along both additional channels shall be 8 in. OC. Additional screws shall

be placed in the adjacent section of gypsum board into the aforementioned 3 in. extension of the extra butt joint channels as well as into the main channel that runs between. Butt joint furring channels shall be attached with one RESILMOUNT Sound Isolation Clip at each end of the channel. When Steel Framing Members (Item 6E) are used, nom 5/8 in. thick, 4 ft wide gypsum board, installed as described in Item 7. Adjacent butt joints staggered minimum 48 in. OC.

When Steel Framing Members (Item 6F) are used, nom 5/8 in. thick, 4 ft wide gypsum board, installed as described in Item 7. Butt joints staggered minimum 24 in. OC.

**AMERICAN GYPSUM CO** — Type AG-C

**CGC INC** — Types C, IP-X2, IPC-AR

**CERTAINTED GYPSUM INC** — Type LGFC-C/A

**GEORGIA-PACIFIC GYPSUM L L C** — Types 5, DAPC, TG-C

**UNITED STATES GYPSUM CO** — Types C, IP-X2, IPC-AR

**USG MEXICO S A DE C V** — Types C, IP-X2, IPC-AR

7A. **Gypsum Board\*** — (As an alternative to Item 7) — For use when no insulation is used. Nom 5/8 in. thick, 48 in. wide gypsum board, installed as described in item 7 with resilient channels (Item 6) spaced 24 in OC.

**AMERICAN GYPSUM CO** — Type AG-C

8. **Finishing System** — (Not Shown) — Vinyl, dry or premixed joint compound, applied in two coats to joints and screw-heads. Nom 2 in. wide paper tape embedded in first layer of compound over all joints. As an alternate, nom 3/32 in. thick veneer plaster may be applied to the entire surface of gypsum board.

**\* Indicates such products shall bear the UL or cUL Certification Mark for jurisdictions employing the UL or cUL Certification (such as Canada), respectively.**

Last Updated on 2022-11-01