

# Design No. L576

February 21, 2023

**Unrestrained Assembly Rating — 1 Hr**  
**Finish Rating — 25 Min (See Items 5 and 5A )**

**This design was evaluated using a load design method other than the Limit States Design Method (e.g., Working Stress Design Method). For jurisdictions employing the Limit States Design Method, such as Canada, a load restriction factor shall be used — See Guide [BXUV](#) or [BXUV7](#)**

**\* Indicates such products shall bear the UL or cUL Certification Mark for jurisdictions employing the UL or cUL Certification (such as Canada), respectively.**

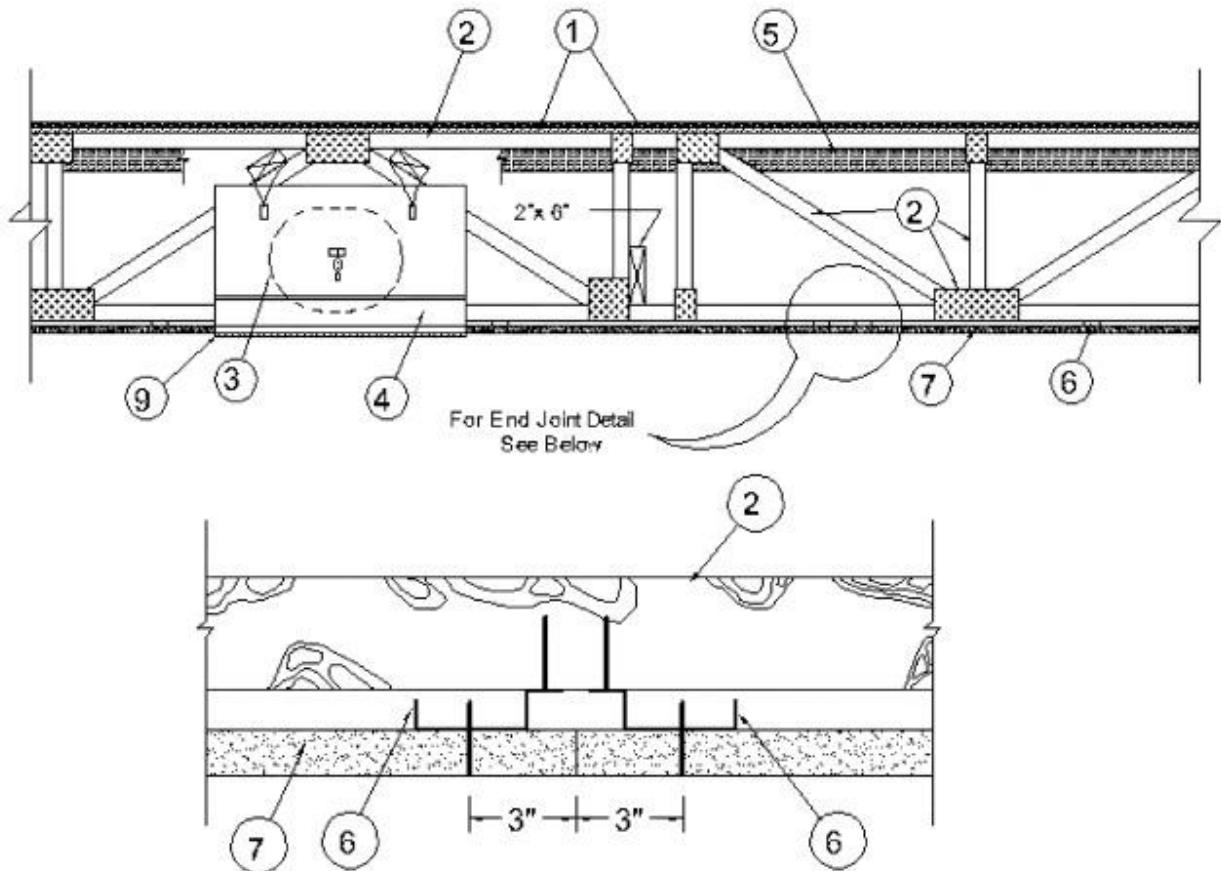

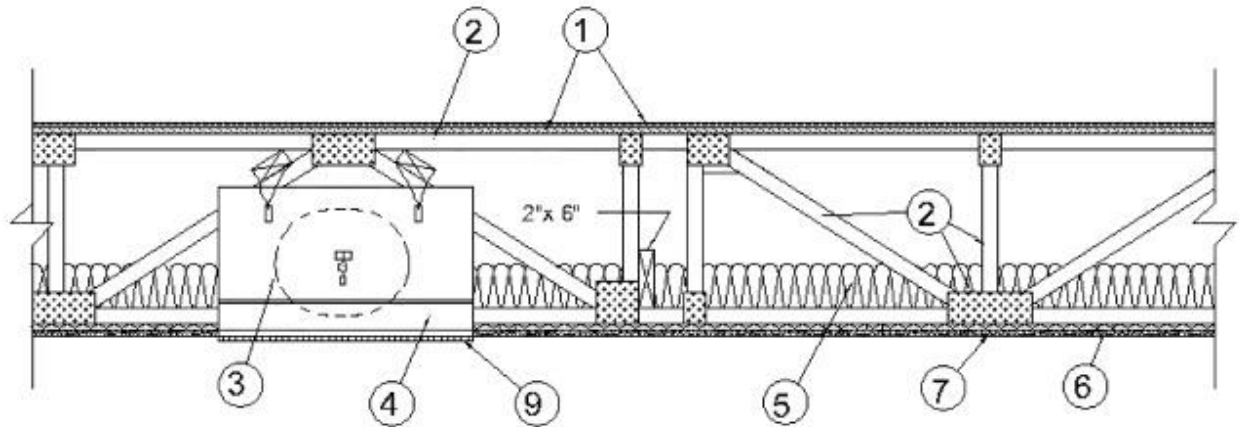

### Alternate Insulation Placement

1. **Flooring System** — The flooring system shall consist of one of the following:

#### System No. 1

**Subflooring** — Nom 23/32 in. thick wood structural panels installed perpendicular to trusses with end joints staggered. Plywood or panels secured to trusses with construction adhesive and No. 6d ringed shank nails, spaced 12 in. OC along each truss. Staples having equal or greater withdrawal and lateral resistance strength may be substituted for the 6d nails.

**Vapor Barrier** — (Optional) — Nom 0.030 in. thick commercial asphalt saturated felt.

**Finish Floor** — Min 1 by 4 in. T & G lumber installed perpendicular to trusses, or min 15/32 in. thick wood structural panels, min grade "Underlayment" or "Single-Floor". Face grain of plywood or strength axis of panel to be perpendicular to joists with joints staggered.

#### System No. 2

**Subflooring** — Nom 23/32 in. thick wood structural panels installed perpendicular to trusses with end joints staggered. Plywood or panels secured to trusses with construction adhesive and No. 6d ringed shank nails, spaced 12 in. OC along each truss. Staples having equal or greater withdrawal and lateral resistance strength may be substituted for the 6d nails.

**Vapor Barrier** — (Optional) — Nom 0.030 in. thick commercial asphalt saturated felt.

**Floor Mat Materials\*** — Floor mat material nom 5/64 in. (2 mm) thick adhered to subfloor with Hacker Floor Primer. Primer to be applied to the surface of the mat prior to the placement of a min 1 in. of floor-topping mixture.

**HACKER INDUSTRIES INC** — Type Hacker Sound-Mat.

**Alternate Floor Mat Materials\*** — (Optional) — Floor mat material nom 1/4 in. (6 mm) thick adhered to subfloor with Hacker Floor Primer. Primer to be applied to the surface of the mat prior to the placement of a min 1-1/4 in. (32 mm) of floor-topping mixture.

**HACKER INDUSTRIES INC** — Type Hacker Sound-Mat II.

**Alternate Floor Mat Materials** — (Optional) — Floor mat material nom 1/8 in. (3 mm) thick loose laid over the subfloor. Floor topping thickness shall be a min of 3/4 in. (19 mm).

**HACKER INDUSTRIES INC** — FIRM-FILL SCM 125

**Alternate Floor Mat Materials\*** — (Optional) — Floor mat material nom 1/4 in. (6 mm) thick loose laid over the subfloor. Floor topping thickness shall be a min of 1 in. (25 mm).

**HACKER INDUSTRIES INC** — Type FIRM-FILL SCM 250, Quiet Qurl 55/025

**Alternate Floor Mat Materials\*** — (Optional) — Floor mat material nom 3/8 in. (10 mm) thick loose laid over the subfloor. Floor topping thickness shall be a min of 1-1/4 in. (32 mm).

**HACKER INDUSTRIES INC** — Type FIRM-FILL SCM 400, Quiet Qurl 60/040

**Alternate Floor Mat Materials** — (Optional) — Floor mat material nom 3/4 in. (19 mm) thick loose laid over the subfloor. Floor topping thickness shall be a min of 1-1/2 in. (38 mm).

**HACKER INDUSTRIES INC** — Type FIRM-FILL SCM 750, Quiet Qurl 65/075

**Metal Lath** — (Optional) — For use with 3/8 in. or 10 mm floor mat materials, 3/8 in. expanded steel diamond mesh, 3.4 lbs/sq yd placed over the floor mat material. Hacker Floor Primer to be applied prior to the placement of the metal lath. When metal lath is used, floor topping thickness a nom 1-1/4 in. over the floor mat.

**Finish Flooring - Floor Topping Mixture\*** — Min 3/4 in. thickness of floor topping mixture having a min compressive strength of 1100 psi. Mixture shall consist of 6.8 gal of water to 80 lbs of floor topping mixture to 1.9 cu ft of sand.

**HACKER INDUSTRIES INC** — Firm-Fill Gypsum Concrete, Firm-Fill 2010, Firm-Fill 3310, Firm-Fill 4010, Firm-Fill High Strength, Gyp-Span Radiant

### **System No. 3**

**Subflooring** — Nom 23/32 in. thick wood structural panels installed perpendicular to trusses with end joints staggered. Plywood or panels secured to trusses with construction adhesive and No. 6d ringed shank nails, spaced 12 in. OC along each truss. Staples having equal or greater withdrawal and lateral resistance strength may be substituted for the 6d nails.

**Vapor Barrier** — (Optional) — Nom 0.030 in. thick commercial asphalt saturated felt.

**Finish Floor — Mineral and Fiber Board\*** — Min 1/2 in. thick, supplied in sizes ranging from 3 ft by 4 ft to 8 ft by 12 ft. All joints to be staggered a min of 12 in. with adjacent sub-floor joints.

**HOMASOTE CO** — Type 440-32 Mineral and Fiber Board

### **System No. 4**

**Subflooring** — Nom 23/32 in. thick wood structural panels installed perpendicular to trusses with end joints staggered. Plywood or panels secured to trusses with construction adhesive and No. 6d ringed shank nails, spaced 12 in. OC along each truss. Staples having equal or greater withdrawal and lateral resistance strength may be substituted for the 6d nails.

**Vapor Barrier** — (Optional) — Nom 0.030 in. thick commercial asphalt saturated felt.

**Floor Mat Materials\*** — (Optional) — Min 3/8 in. to max 3/4 in. thick floor mat material loose laid over the subfloor.

**UNITED STATES GYPSUM CO** — LEVELROCK® Brand Sound Reduction Board

**Alternate Floor Mat Materials\*** — (Optional) — Nom 1/4 in. thick floor mat material loose laid over the subfloor. Floor topping thickness shall be as specified under Floor Topping Mixture.

**UNITED STATES GYPSUM CO** — LEVELROCK® Brand Floor Underlayment SRM-25

**Alternate Floor Mat Materials\*** — (Optional) — Floor mat material loose laid over the subfloor. Refer to manufacturer's instructions regarding minimum thickness of floor topping over floor mat.  
**GRASSWORX L L C** — SC Types

**Finish Flooring — Floor Topping Mixture\*** — Min 1/2 in. thickness of floor topping mixture having a min compressive strength of 1500 psi. Refer to manufacturer's instructions accompanying the material for specific mix design.

**UNITED STATES GYPSUM CO** — Type LRK

### **System No. 5**

**Subflooring** — Nom 23/32 in. thick wood structural panels installed perpendicular to trusses with end joints staggered. Plywood or panels secured to trusses with construction adhesive and No. 6d ringed shank nails, spaced 12 in. OC along each truss. Staples having equal or greater withdrawal and lateral resistance strength may be substituted for the 6d nails.

**Vapor Barrier** — (Optional) — Nom 0.030 in. thick commercial asphalt saturated felt.

**Floor Mat Materials\*** — (Optional) — Min 3/8 in. to max 3/4 in. thick floor mat material loose laid over the subfloor.

**UNITED STATES GYPSUM CO** — LEVELROCK® Brand Sound Reduction Board

**Alternate Floor Mat Materials\*** — (Optional) — Nom 1/4 in. thick floor mat material loose laid over the subfloor.

**UNITED STATES GYPSUM CO** — LEVELROCK® Brand Floor Underlayment SRM-25

**Alternate Floor Mat Materials\*** — (Optional) — Floor mat material loose laid over the subfloor. Refer to manufacturer's instructions regarding minimum thickness of floor topping over floor mat.

**GRASSWORX L L C** — SC Types

**Finish Flooring — Floor Topping Mixture\*** — Min 1/2 or in. thickness of floor topping mixture having a min compressive strength of 2100 psi. Refer to manufacturer's instructions accompanying the material for specific mix design.

**UNITED STATES GYPSUM CO** — LEVELROCK® Brand 3500, Brand Commercial RH

### **System No. 6**

**Subflooring** — Nom 23/32 in. thick wood structural panels installed perpendicular to trusses with end joints staggered. Plywood or panels secured to trusses with construction adhesive and No. 6d ringed shank nails, spaced 12 in. OC along each truss. Staples having equal or greater withdrawal and lateral resistance strength may be substituted for the 6d nails.

**Vapor Barrier** — (Optional) — Nom 0.030 in. thick commercial asphalt saturated felt.

**Floor Mat Materials\*** — (Optional) — Min 3/8 in. to max 3/4 in. thick floor mat material loose laid over the subfloor.

**UNITED STATES GYPSUM CO** — LEVELROCK® Brand Sound Reduction Board

**Alternate Floor Mat Materials\*** — (Optional) — Nom 1/4 in. thick floor mat material loose laid over the subfloor. Floor topping thickness shall be as specified under Floor Topping Mixture.

**UNITED STATES GYPSUM CO** — LEVELROCK® Brand Floor Underlayment SRM-25

**Alternate Floor Mat Materials\*** — (Optional) — Nom 3/8 in. thick floor mat material loose laid over the subfloor.

**GRASSWORX L L C** — Type SC50

**Finish Flooring — Floor Topping Mixture\*** — Min 1/2 in. thickness of floor topping mixture having a min compressive strength of 3000 psi. Refer to manufacturer's instructions accompanying the material for specific mix design.

#### **System No. 7**

**Subflooring** — Nom 23/32 in. thick wood structural panels installed perpendicular to trusses with end joints staggered. Plywood or panels secured to trusses with construction adhesive and No. 6d ringed shank nails, spaced 12 in. OC along each truss. Staples having equal or greater withdrawal and lateral resistance strength may be substituted for the 6d nails.

**Vapor Barrier** — (Optional) — Nom 0.030 in. thick commercial asphalt saturated felt.

**Finish Flooring - Floor Topping Mixture\*** — Min 3/4 in. thickness of floor topping having a min compressive strength of 1000 psi. Refer to manufacturer's instructions accompanying the material for specific mix design.

**ARCOSA SPECIALTY MATERIALS** — AccuCrete® Types NexGen, Green, Prime and PrePour, AccuRadiant®, AccuLevel® Types G40, G50 and SD30

**Alternate Floor Mat Material\*** — (Optional) — Floor mat material nominal 2 - 9.5 mm thick loose laid over the subfloor. Floor topping shall be a min of 3/4 in.

**ARCOSA SPECIALTY MATERIALS** — AccuQuiet® Types D13, D-18, D25, DX38, EM.125, EM.125S, EM.250, EM.250S, EM.375, EM.375S, EM.750, and EM.750S..

#### **System No. 8**

**Subflooring** — Min 15/32 in. thick wood structural panels, min grade "C-D" or "Sheathing". Face grain of plywood or strength axis of panels to be perpendicular to the joists with joints staggered.

**Vapor Barrier** — (Optional) — Commercial asphalt saturated felt, 0.030 in. thick.

**Vapor Barrier** — (Optional) — Nom 0.010 in. thick commercial rosin-sized building paper.

**Finish Flooring\*** — Min 3/4 in. thickness of any Floor Topping Mixture bearing the UL Classification Marking as to Fire Resistance. See Floor- and Roof-Topping Mixtures (CCOX) category for names of Classified Companies. Refer to the manufacturer's instructions accompanying the material and/or contact the manufacturer's technical support for specific mix design and minimum thickness recommended for use with eligible floor mat(s).

**Floor Mat Materials\*** — (Optional) — Nom. 1/4 in. thick loose laid over the subfloor. Floor topping thickness shall be a minimum of 3/4 in.

**KEENE BUILDING PRODUCTS CO INC** — Type Quiet Qurl 55/025 and Quiet Qurl 55/025 N

**Alternate Floor Mat Materials\*** — (Optional) — Floor mat material Nom. 3/8 in. thick loose laid over the subfloor. Floor topping thickness shall be a minimum of 1 in.

**KEENE BUILDING PRODUCTS CO INC** — Type Quiet Qurl 60/040 and Quiet Qurl 60/040 N

**Alternate Floor Mat Materials\*** — (Optional) — Floor mat material Nom. 3/4 in. thick loose laid over the subfloor. Floor topping thickness shall be a minimum of 1-1/2 in.

**KEENE BUILDING PRODUCTS CO INC** — Type Quiet Qurl 65/075, Quiet Qurl 65/075 N

**Alternate Floor Mat Materials\*** — (Optional) — Floor mat material Nom. 1/8 in. thick loose laid over the subfloor. Floor topping thickness shall be a minimum of 3/4 in.

**KEENE BUILDING PRODUCTS CO INC** — Type Quiet Qurl 52/013 and Quiet Qurl 52/013 N

**Alternate Floor Mat Materials\*** — (Optional) — Floor mat material Nom. 1/4 in. entangled net core with a compressible fabric attached to the bottom loose laid over the subfloor. Floor topping thickness shall be a minimum of 1 in.

**KEENE BUILDING PRODUCTS CO INC** — Quiet Qurl 55/025 MT and Quiet Qurl 55/025 N MT

### **System No. 9**

**Subflooring** — Nom 23/32 in. thick wood structural panels installed perpendicular to trusses with end joints staggered. Plywood or panels secured to trusses with construction adhesive and No. 6d ringed shank nails, spaced 12 in. OC along each truss. Staples having equal or greater withdrawal and lateral resistance strength may be substituted for the 6d nails.

**Vapor Barrier** — (Optional) — Nom 0.030 in thick commercial asphalt saturated felt.

**Finish Flooring — Floor Topping Mixture\*** — — Min. 3/4 in. thickness of floor topping mixture having a minimum compressive strength to be 1500 psi. Refer to manufacturer's instructions accompanying the material for specific mix design.

**MAXXON CORP** — Type Maxxon Standard and Maxxon High Strength

**Floor Mat Materials\*** — (Optional) — Floor mat material loose laid over the subfloor. Refer to manufacturer's instructions regarding the minimum thickness of floor topping over each floor mat material.

**MAXXON CORP** — Type Encapsulated Sound Mat.

**Floor Mat Reinforcement** — (Optional) - Refer to manufacturer's instructions regarding minimum thickness of floor topping for use with floor mat reinforcement.

**Metal Lath** — (Optional) — 3/8 in. expanded galvanized steel diamond mesh, 3.4 lbs/sq yd loose laid over the floor mat material.

**Fiber Glass Reinforcement** — (Optional) - 0.015 in. thick PVC coated non-woven fiberglass mesh, 0.368 lbs./sq. yd loose laid over the floor mat material.

#### **System No. 10**

**Subflooring** — Nom 23/32 in. thick wood structural panels installed perpendicular to trusses with end joints staggered. Plywood or panels secured to trusses with construction adhesive and No. 6d ringed shank nails, spaced 12 in. OC along each truss. Staples having equal or greater withdrawal and lateral resistance strength may be substituted for the 6d nails.

**Vapor Barrier** — (Optional) — Nom 0.030 in. thick commercial asphalt saturated felt

**Finish Flooring — Floor Topping Mixture\*** — Min 3/4 in. thickness of floor topping having a min compressive strength of 1000 psi. Refer to manufacturer's instructions accompanying the material for specific mix design.

**FORMULATED MATERIALS LLC** — Types FR-25, FR-30, and SiteMix

**Alternate Floor Mat Material\*** — (Optional) Floor mat material nominal 2 - 9.5 mm thick loose laid over the subfloor. Floor topping shall be a min of 3/4 in.

**FORMULATED MATERIALS LLC** — Types M1, M2, M3, Elite, Duo, R1, and R2

#### **System No. 11**

**Subflooring** — Nom 23/32 in. thick wood structural panels installed perpendicular to trusses with end joints staggered. Plywood or panels secured to trusses with construction adhesive and No. 6d ringed shank nails, spaced 12 in. OC along each truss. Staples having equal or greater withdrawal and lateral resistance strength may be substituted for the 6d nails.

**Vapor Barrier** — (Optional) — Nom 0.030 in. thick commercial asphalt saturated felt.

**Finish Flooring — Floor Topping Mixture\*** — Min 3/4 in. thickness of floor topping having a min compressive strength of 1000 psi. Refer to manufacturer's instructions accompanying the material for specific mix design.

**DEPENDABLE LLC** — GSL M3.4, GSL K2.6, GSL-CSD and GSL RH.

**Floor Mat Materials\*** — (Optional) — Nom. 1/4 in. thick loose laid over the subfloor. Floor topping thickness shall be a minimum of 3/4 in.

**KEENE BUILDING PRODUCTS CO INC** — Type Quiet Qurl 55/025 and Quiet Qurl 55/025 N

**Alternate Floor Mat Materials\*** — (Optional) — Floor mat material Nom. 3/8 in. thick loose laid over the subfloor. Floor topping thickness shall be a minimum of 1 in.

**KEENE BUILDING PRODUCTS CO INC** — Type Quiet Qurl 60/040 and Quiet Qurl 60/040 N

**Alternate Floor Mat Materials\*** — (Optional) — Floor mat material Nom. 3/4 in. thick loose laid over the subfloor. Floor topping thickness shall be a minimum of 1-1/2 in.

**KEENE BUILDING PRODUCTS CO INC** — Type Quiet Qurl 65/075, Quiet Qurl 65/075 N

**Alternate Floor Mat Materials\*** — (Optional) — Floor mat material Nom. 1/8 in. thick loose laid over the subfloor. Floor topping thickness shall be a minimum of 3/4 in.

**KEENE BUILDING PRODUCTS CO INC** — Type Quiet Qurl 52/013 and Quiet Qurl 52/013 N

**Alternate Floor Mat Materials\*** — (Optional) — Floor mat material Nom. 1/4 in. entangled net core with a compressible fabric attached to the bottom loose laid over the subfloor. Floor topping thickness shall be a minimum of 1 in.

**KEENE BUILDING PRODUCTS CO INC** — Quiet Qurl 55/025 MT and Quiet Qurl 55/025 N MT

### **System No. 12**

**Subflooring** — Nom 23/32 in. thick wood structural panels installed perpendicular to trusses with end joints staggered. Plywood or panels secured to trusses with construction adhesive and No. 6d ringed shank nails, spaced 12 in. OC along each truss. Staples having equal or greater withdrawal and lateral resistance strength may be substituted for the 6d nails.

**Finish Flooring - Floor Topping Mixture\*** — Min 1 in. thickness of floor topping mixture having a min compressive strength of 4500 psi. Refer to manufacturer's instructions accompanying the material for specific mix design.

**SIKA DEUTSCHLAND GMBH** — Type SCHONOX AP Rapid Plus

### **System No. 13**

**Subflooring** — Nom 23/32 in. thick wood structural panels installed perpendicular to trusses with end joints staggered. Plywood or panels secured to trusses with construction adhesive and No. 6d ringed shank nails, spaced 12 in. OC along each truss. Staples having equal or greater withdrawal and lateral resistance strength may be substituted for the 6d nails.

**Vapor Barrier** — (Optional) - Commercial asphalt saturated felt, 0.030 in. thick.

**Vapor Barrier** — (Optional) - Nom 0.010 in. thick commercial rosin-sized building paper.

**Finish Flooring - Floor Topping Mixture\*** — Min 3/4 in. thickness of any Floor Topping Mixture bearing the UL Classification Marking as to Fire Resistance. See Floor- and Roof-Topping Mixtures (CCOX) category for names of Classified Companies. Refer to the manufacturer's instructions accompanying the material and/or contact the manufacturer's technical support for specific mix design and minimum thickness recommended for use with eligible floor mat(s).

**Floor Mat Materials\*** — (Optional, Not Shown) - Floor mat material loose laid over the subfloor. Refer to manufacturer's instructions regarding the minimum thickness of floor topping over each floor mat material.

**LOW & BONAR INC** — EnkaSonic® by Colbond a member of the Low & Bonar group Types 125, 250, 250 Plus, 400, 400 Plus, 750 and 750 Plus.



**Floor Mat Reinforcement** — (Optional) - Refer to manufacturer's instructions regarding minimum thickness of floor topping for use with floor mat reinforcement.

**Metal Lath** — (Optional) — Expanded steel diamond mesh, 2.5 lb / sq yd loose laid over floor mat material.

**Fiberglass Mesh Reinforcement** — (Optional) — Coated non-woven glass fiber mesh grid loose laid over floor mat material.

### **System No. 14**

**Subflooring** — Nom 23/32 in. thick wood structural panels installed perpendicular to trusses with end joints staggered. Plywood or panels secured to trusses with construction adhesive and No. 6d ringed shank nails, spaced 12 in. OC along each truss. Staples having equal or greater withdrawal and lateral resistance strength may be substituted for the 6d nails.

**Vapor Barrier — (Optional)** — Nom 0.030 in. thick commercial asphalt saturated felt.

**Floor Mat Materials\*** — (Optional) — Floor mat material loose laid over the subfloor. Refer to manufacturer's instructions regarding the minimum thickness of floor topping over each floor mat material.

### **GRASSWORX L L C** — SC Types

**Finish Flooring\*** — Min 3/4 in. thickness of any Floor Topping Mixture bearing the UL Classification Marking as to Fire Resistance. See Floor- and Roof-Topping Mixtures (CCOX) category for names of Classified Companies. Refer to the manufacturer's instructions accompanying the material and/or contact the manufacturer's technical support for specific mix design and minimum thickness recommended for use with eligible floor mat(s).

**Floor Mat Reinforcement** — (Optional) - Refer to manufacturer's instructions regarding minimum thickness of floor topping for use with floor mat reinforcement.

**Metal Lath** — (Optional) — Expanded steel diamond mesh, 2.5 lb / sq yd loose laid over floor mat material.

**Fiberglass Mesh Reinforcement** — (Optional) — Coated non-woven glass fiber mesh grid loose laid over floor mat material.

2. **Trusses** — Parallel chord trusses, spaced a max of 24 in. OC, fabricated from nom 2 by 4 lumber, with lumber oriented vertically or horizontally. Min truss depth is 12 in. when no **Ceiling Damper\*** is used and 18 in. when a **Ceiling Damper\*** is used. Truss members secured together with min 0.0356 in. thick galv steel plates. Plates have 5/16 in. long teeth projecting perpendicular to the plane of the plate. The teeth are in pairs facing each other (made by the same punch), forming a split tooth type plate. Each tooth has a chisel point on its outside edge. These points are diagonally opposite each other for each pair. The top half of each tooth has a twist for stiffness. The pairs are repeated on approx. 7/8 in. centers with four rows of teeth per inch of plate width.

3. **Air Duct** — Optional- for use with ceiling dampers. - Any UL Class 0 or Class 1 flexible air duct installed in accordance with the instructions provided by the damper manufacturer.

4. **Ceiling Damper\*** — Optional- Max nom area shall be 324 sq in. Max square size shall be 18 in. by 18 in. Rectangular sizes not to exceed 324 sq in. with a max width of 18 in. Max height of damper shall be 14 in. Aggregate damper openings shall not exceed 162 sq in. per 100 sq ft of ceiling area. Damper installed in accordance with the manufacturers installation instructions provided with the damper. A steel grille (Item 9) shall be installed in accordance with installation instructions.

**C&S AIR PRODUCTS** — Model RD-521

**POTTORFF** — Model CFD-521.

4A. **Alternate Ceiling Damper\*** — Optional- Max nom area shall be 196 sq in. Max square size shall be 14 in. by 14 in. Rectangular sizes not to exceed 196 sq in. with a max width of 26 in. Max height of damper shall be 7 in. Aggregate damper openings shall not exceed 98 sq in. per 100 sq ft of ceiling area. Damper installed in accordance with the manufacturers installation instructions provided with the damper. A steel grille (Item 9) not to exceed 196 in.<sup>2</sup> shall be installed in accordance with installation instructions.

**C&S AIR PRODUCTS** — Model RD-521-BT

**POTTORFF** — Model CFD-521-BT.

4B. **Alternate Ceiling Damper\*** — Optional- Max nom area shall be 256 sq in. with the length not to exceed 24 in. and the width not to exceed 20 in. Max height of damper shall be 17 in. Aggregate damper openings shall not exceed 128 sq in. per 100 sq ft of ceiling area. Damper installed in accordance with the manufacturers installation instructions provided with the damper. A steel grille (Item 9) shall be installed in accordance with installation instructions.

**C&S AIR PRODUCTS** — Model RD-521-IP, RD-521-NP

**POTTORFF** — Models CFD-521-IP, CFD-521-NP

4C. **Alternate Ceiling Damper\*** — Optional- Max nom area shall be 144 sq in. with the length not to exceed 14 in. and the width not to exceed 12 in. Max height of damper shall be 17-7/8 in. Aggregate damper openings shall not exceed 74 sq in. per 100 sq ft of ceiling area. Damper installed in accordance with the manufacturers installation instructions provided with the damper. A steel grille (Item 9) shall be installed in accordance with installation instructions.

**C&S AIR PRODUCTS** — Model RD-521-90, RD-521-NP90

**POTTORFF** — Models CFD-521-90, CFD-521-90NP

4D. **Alternate Ceiling Damper\*** — Optional- Ceiling damper & fan assembly. Max nom area shall be 75 sq in. with the length not to exceed 8-9/16 in. and the width not to exceed 8-3/4 in. Max height of damper shall be 9-7/8 in. Aggregate damper openings shall not exceed 38 sq in. per 100 sq ft of ceiling area. Damper shall be installed in combination with one of the fan models described in, and in

accordance with, the manufacturers installation instructions provided with the damper. A plastic grille (Item 9) shall be installed in accordance with installation instructions.

**DELTA ELECTRONICS INC** — Models CRD2, GBR-CRD, ITG-CRD

4E. **Alternate Ceiling Damper\*** — Optional- Ceiling damper & fan assembly. Max nom area shall be 75 sq in. with the length not to exceed 9-1/4 in. and the width not to exceed 9-3/4 in. Max height of damper shall be 9-7/8 in. Aggregate damper openings shall not exceed 45 sq in. per 100 sq ft of ceiling area. Damper shall be installed in combination with one of the fan models described in, and in accordance with, the manufacturer's installation instructions provided with the damper. A plastic grille (Item 9) shall be installed in accordance with installation instructions.

**DELTA ELECTRONICS INC** — Model SIG-CRD

4F. **Alternate Ceiling Damper\*** — Optional- Ceiling damper & fan assembly. Max nom area shall be 131 sq in. with the length not to exceed 11-1/16 in. and the width not to exceed 11-7/8 in. Aggregate damper openings shall not exceed 66 sq in. per 100 sq ft of ceiling area. Damper shall be installed in combination with one of the fan models described in, and in accordance with, the manufacturer's installation instructions provided with the damper. A plastic grille (Item 9) shall be installed in accordance with installation instructions.

**DELTA ELECTRONICS INC** — Model SMT-CRD

4G. **Alternate Ceiling Damper\*** — Optional- Ceiling damper & fan assembly. Max nom area shall be 103 sq in. with the length not to exceed 10-1/8 in. and the width not to exceed 10-1/8 in. Aggregate damper openings shall not exceed 52 sq in. per 100 sq ft of ceiling area. Damper shall be installed in combination with one of the fan models described in, and in accordance with, the manufacturer's installation instructions provided with the damper. A plastic grille (Item 9) shall be installed in accordance with installation instructions.

**PANASONIC CORPORATION, PANASONIC CORPORATION OF NORTH AMERICA** — Model PC-RD05C5

4H. **Alternate Ceiling Damper\*** — Optional- Ceiling damper & fan assembly. Max nom area shall be 113 sq in. with the length not to exceed 10-1/8 in. and the width not to exceed 11-1/8 in. Aggregate damper openings shall not exceed 57 sq in. per 100 sq ft of ceiling area. Damper shall be installed in combination with one of the fan models described in, and in accordance with, the manufacturer's installation instructions provided with the damper. A plastic grille (Item 9) shall be installed in accordance with installation instructions.

**BROAN-NUTONE L L C** — Model RDFUWT

4I. **Alternate Ceiling Damper\*** — Optional- Ceiling damper & fan assembly. Max nom area shall be 79 sq in. with the length not to exceed 10 in. and the width not to exceed 7-15/16 in. Aggregate damper openings shall not exceed 40 sq in. per 100 sq ft of ceiling area. Damper shall be installed in combination with one of the fan models described in, and in accordance with, the manufacturer's installation instructions provided with the damper. A metallic grille (Item 9) shall be installed in accordance with installation instructions.

**BROAN-NUTONE L L C** — Models RDJ1 and RDH

4J. **Alternate Ceiling Damper\*** — Optional- Ceiling damper & fan assembly. Max nom area shall be 87 sq in. with the length not to exceed 9 in. and the width not to exceed 9-11/16 in. Aggregate damper openings shall not exceed 44 sq in. per 100 sq ft of ceiling area. Damper shall be installed in

combination with one of the fan models described in, and in accordance with, the manufacturer's installation instructions provided with the damper. A plastic grille (Item 9) shall be installed in accordance with installation instructions.

**BROAN-NUTONE L L C** — Model RDMWT

4K. **Alternate Ceiling Damper\*** — Optional- Ceiling damper & fan assembly.. Max nom area shall be 87 sq in. with the length not to exceed 9 in. and the width not to exceed 9-11/16 in. Aggregate damper openings shall not exceed 44 sq in. per 100 sq ft of ceiling area. Damper shall be installed in combination with one of the fan models described in, and in accordance with, the manufacturer's installation instructions provided with the damper. A plastic grille (Item 9) shall be installed in accordance with installation instructions.

**BROAN-NUTONE L L C** — Model RDMWT2

4L. **Damper\*** — Optional, —Max nom 21 in. long by 18 in. wide, fabricated from galvanized steel. Plenum box max size nom 21 in. long by 18 in. wide by 14 in. high (inner dimension) fabricated from either galvanized steel or min 1 in. thick Listed Duct Board bearing the UL Listing Marking having a min R-Value of 4.3. Installed in accordance with the instructions provided by the manufacturer. Max damper openings not to exceed 180 sq in. per 100 sq ft of ceiling area.

**GREENHECK FAN CORP** — Model CRD-1WT

4M. **Damper\*** — Optional —Max nom 12 in. long by 12 in. wide with an 8 in. diameter damper, fabricated from galvanized steel. Installed in accordance with the instructions provided by the manufacturer. Max damper openings not to exceed 72 sq in. per 100 sq ft of ceiling area.

**GREENHECK FAN CORP** — Model CRD-2WT

4N. **Damper\*** — (Optional) Max nom 11-1/8 in. long by 13-5/8 in. wide, fabricated from galvanized steel. Installed in accordance with the instructions provided by the manufacturer. Max damper openings not to exceed 76 sq in. per 100 sq ft of ceiling area.

**GREENHECK FAN CORP** — Model CRD-310WT

4O. **Damper\*** — (Optional-) Max nom 12-3/8 in. long by 14-1/2 in. wide, fabricated from galvanized steel. Installed in accordance with the instructions provided by the manufacturer. Max damper openings not to exceed 90 sq in. per 100 sq ft of ceiling area.

**GREENHECK FAN CORP** — Model CRD-320WT

4P. **Alternate Ceiling Damper** - (Optional-) Maximum 20 in. long by 18 in. wide by 2-1/8 in. high, fabricated from galvanized steel. Plenum box maximum size nom. 21 in. long by 18 in. wide by 16 in. high fabricated from either galvanized steel or Classified Air Duct Materials bearing the UL Class 0 or Class 1 rigid air duct material. Installed in accordance with the instructions provided by the manufacturer. Max damper openings not to exceed 180 sq in. per 100 sq ft of ceiling area.

**NAILOR INDUSTRIES INC** — Types 0755, 0755A, 0756, 0756D, 0757, 0757D, 0757FP, 0757DFP, 0763

**SAFE AIR DOWCO** — 0455, 0455A, 0456, 0456D, 0457, 0457D, 0457-DB, 0457-CB, 0463-FB, 0457-EB, 0463-GB, 0463

4Q. **Alternate Ceiling Damper\*** — (Optional-) Max nom 10-3/8 in. long by 10-3/8 in. wide, fabricated from galvanized steel. Installed in accordance with the instructions provided by the manufacturer. Max damper openings not to exceed 54 sq in. per 100 sq ft of ceiling area.

**GREENHECK FAN CORP** — Model CRD-300WT

5. **Batts and Blankets\*** — Glass fiber or mineral wool insulation bearing the UL Classification Marking as to Surface Burning Characteristics and/or Fire Resistance. When the resilient channels (Item 6) or furring channels (Item 6A, 6I) are spaced 16 in. OC, the insulation shall be a max of 3-1/2 in. thick, and shall be secured against the subflooring with staples at 12 in. OC or held suspended in the concealed space with 0.090 in. diam galv steel wires attached to the wood trusses at 12 in. OC. When the resilient channels (Item 6) or furring channels (Item 6A, 6I) are spaced a max of 12 in. OC or when the Steel Framing Members (Item 6B) are used, there is no limit in the overall thickness of insulation, and the insulation can be secured against the subflooring, held suspended in the concealed space or draped over the resilient or furring channels (or Steel Framing Members) and gypsum panel membrane. The finished rating has only been determined when the insulation is secured to the subflooring.

5A. **Fiber, Sprayed** — (Dry Dense Packed 100% Borate Formulation) — As an alternate to Item 5 — The finished rating when Fiber, Sprayed is used has not been determined. The fiber is applied without water or adhesive at a nominal dry density of 3.5 lb/ft<sup>3</sup>, in accordance with the application instructions supplied with the product. When Item 5A (Fiber Sprayed, Dry Dense Packed) is used, two layers of gypsum board required as described in Item 7. Not evaluated for use with Item 6B.

**APPLEGATE GREENFIBER ACQUISITION LLC** — INS735, INS745, INS750LD, INS765LD, INS773LD, Insulmax, & SANCTUARY to be used with dry application only.

5B. **Fiber, Sprayed** — (Loose Fill 100% Borate Formulation) — As an alternate to Items 5 and 5A — The finished rating when Fiber, Sprayed is used has not been determined. The fiber is applied without water or adhesive at a minimum dry density of 0.5 lb/ft<sup>3</sup> and at a max thickness of 3-1/2 in., in accordance with the application instructions supplied with the product. When Item 5B (Fiber Sprayed, Loose Fill) is used, two layers of gypsum board required as described in Item 7. Not evaluated for use with Item 6B.

**APPLEGATE GREENFIBER ACQUISITION LLC** — INS735, INS745, INS750LD, INS765LD, INS773LD, Insulmax, & SANCTUARY to be used with dry application only.

6. **Furring Channels** — Resilient channels formed of 25 MSG thick galv steel, spaced 16 in. OC perpendicular to trusses. When insulation, Items 5, 5A or 5B is applied over the resilient channel/gypsum panel ceiling membrane, the resilient channel spacing shall be reduced to 12 in. OC. Channels secured to each truss with 1-1/4 in. long Type S bugle head steel screws. Channels overlapped 4 in. at splices. Two channels, spaced 6 in. OC, oriented opposite each gypsum panel end joint as shown in the above illustration. Additional channels shall extend min 6 in. beyond each side edge of panel.

6A. **Steel Framing Members\*** — (Not Shown) — As an alternate to Item 6.

a. **Furring Channels** — Formed of No. 25 MSG galv steel, 2-9/16 in. or 2-23/32 in. wide by 7/8 in. deep, spaced 16 in. OC perpendicular to wood structural members. When insulation, Items 5, 5A or 5B is applied over the resilient channel/gypsum panel ceiling membrane, the resilient channel spacing shall be reduced to 12 in. OC. Channels secured to trusses as described in Item b. Ends of adjoining channels overlapped 6 in. and tied together with double strand of No. 18 AWG galv steel wire near each end of overlap.

b. **Steel Framing Members\*** — Used to attach furring channels (Item a) to trusses (Item 2). Clips spaced 48 in. OC, and secured to alternating trusses with No. 8 x 2-1/2 in. course drywall screw through the center grommet. When insulation, Items 5, 5A or 5B is applied over the resilient channel/gypsum panel ceiling membrane, the clip spacing shall be reduced to 12 in. OC and secured to consecutive trusses. Furring channels are friction fitted into clips. RSIC-1 clip for use with 2-9/16 in. wide furring channels. RSIC-1 (2.75) clip for use with 2-23/32 in. wide furring channels. Adjoining channels are overlapped as described in Item a. As an alternate, ends of adjoining channels may be overlapped 6 in. and secured together with two self-tapping No. 6 framing screws, min 7/16 in. long at the midpoint of the overlap, with one screw on each flange of the channel. Additional clips required to hold furring channel that supports the gypsum board butt joints, as described in Item 7. When **Fiber, Sprayed** (Item 5B) is used, two layers of nom 5/8 in. thick, 4 ft wide gypsum board shall be installed as described in Item 7.

**PAC INTERNATIONAL L L C** — Types RSIC-1, RSIC-1 (2.75).

6B. **Alternate Steel Framing Members** — (Not Shown) — As an alternate to Items 6 and 6A, main runners, cross tees, cross channels and wall angle as listed below.

a. **Main Runners** — Nom 10 or 12 ft long, 15/16 in. or 1-1/2 in. wide face, spaced 4 ft. OC. Main runners suspended by min 12 SWG galv steel hanger wires spaced 48 in. OC. Hanger wires to be located adjacent to main runner/cross tee intersections. Hanger wires wrapped and twist-tied on 16d nails driven in to side of trusses at least 5 in. above the bottom face.

b. **Cross Tees** — Nom 4 ft long, 1-1/2 in. wide face, installed perpendicular to the main runners, spaced 16 in. OC. When Batts and Blankets\* (Item 5) are used, cross tees spaced 12 in. OC. Additional cross tees or cross channels used at 8 in. from each side of butted gypsum panel end joints. The cross tees or cross channels may be riveted or screw attached to the wall angle or channel to facilitate the ceiling installation.

c. **Cross Channels** — Nom 4 or 12 ft long, installed perpendicular to main runners, spaced 16 in. OC. When Batts and Blankets\* (Item 5) are used, cross channels spaced 16 in. OC.

d. **Wall Angle or Channel** — Painted or galv steel angle with 1 in. legs or channel with 1 in. legs, 1-9/16 in. deep attached to walls at perimeter of ceiling with fasteners 16 in. OC. To support steel framing member ends and for screw-attachment of the gypsum panel.

**CGC INC** — Type DGL or RX

**USG INTERIORS LLC** — Type DGL or RX

6C. **Steel Framing Members\*** — (Not Shown) — As an alternate to Item 6.

a. **Furring Channels** — Formed of No. 25 MSG galv steel, 2-3/8 in. wide by 7/8 in. deep, spaced 16 in. OC perpendicular to wood structural members. When insulation, Item 5, is applied over the resilient channel/gypsum panel ceiling membrane, the resilient channel spacing shall be reduced to 12 in. OC. Channels secured to trusses as described in Item b. Ends of adjoining channels overlapped 6 in. and tied together with double strand of No. 18 AWG galv steel wire near each end of overlap.

b. **Steel Framing Members\*** — Used to attach furring channels (Item a) to trusses (Item 2). Clips spaced 48 in. OC, and secured to alternating trusses with No. 8 x 2-1/2 in. course drywall screw through the center grommet. When insulation, Item 5, is applied over the resilient channel/gypsum

panel ceiling membrane, the clip spacing shall be reduced to 12 in. OC and secured to consecutive trusses. Furring channels are friction fitted into clips. Adjoining channels are overlapped as described in Item a. As an alternate, ends of adjoining channels may be overlapped 6 in. and secured together with two self-tapping No. 6 framing screws, min 7/16 in. long at the midpoint of the overlap, with one screw on each flange of the channel. Additional clips required to hold furring channel that supports the gypsum board butt joints, as described in Item 7. Not evaluated for use with Items 5A or 5B.

**PLITEQ INC** — Type GENIECLIP

**6D. Alternate Steel Framing Members\*** — (Not Shown) — As an alternate to item 6, furring channels and Steel Framing Members as described below.

a. **Furring Channels** — Formed of No. 25 MSG galv steel, 2-5/8 in. wide by 7/8 in deep, spaced 16 in. OC, perpendicular to trusses. When insulation, Items 5, is applied over the resilient channel/gypsum panel ceiling membrane, the resilient channel spacing shall be reduced to 12 in. OC. Channels secured to trusses as described in Item b.

b. **Steel Framing Members\*** — Used to attach furring channels (Item a) to the trusses (Item 2). Clips spaced at 48" OC and secured to the bottom of the trusses with one 2 in. Coarse Drywall Screw with 1 in. diam washer through the center hole. Furring channels are then friction fitted into clips. Ends of channels are overlapped 6" and tied together with double strand of No. 18 AWG galvanized steel wire. Additional clips are required to hold the Gypsum Butt joints as described in item 7.

**STUDCO BUILDING SYSTEMS** — RESILMOUNT Sound Isolation Clips - Type A237 or A237R

**6E. Steel Framing Members\*** — (Optional, Not Shown) — As an alternate to Item 6.

a. **Furring Channels** — Formed of No. 25 MSG galv steel, nominal 2-1/2 in. wide by 7/8 in. deep, spaced as indicated in Item 6, perpendicular to the trusses. Channels secured to Cold Rolled Channels at every intersection with a 3/4 in. TEK screw through each furring channel leg. Ends of adjoining channels overlapped 12 in. and fastened together with two double strand No. 18 SWG galv steel wire ties, one at each end of overlap, or with two 3/4 in. TEK screws in each leg of the overlap section. Two furring channels used at end joints of gypsum board (Item 7), each extending a min of 6 in. beyond both side edges of the board.

b. **Cold Rolled Channels** — 1-1/2 in. by 1/2 in., formed from No. 16 ga. galv steel, positioned vertically and parallel to trusses, friction-fitted into the channel caddy on the Steel Framing Members (Item 6Ed) and secured with two 3/4 in. TEK screws. Adjoining lengths of cold rolled channels lapped min. 12 in. and secured along bottom legs with four 3/4 in. TEK screws and wire-tied together with two double strand 18 SWG galv steel wire ties, one at each end of overlap.

c. **Blocking** — Where truss design does not permit direct, full contact of the hanger bracket, a piece of nominal 2 by 4 in. lumber (blocking), min. 12 in. long to permit full contact of the hanger bracket, to be secured vertically to the side of the trusses at the top and bottom of the blocking at each Steel Framing Member (Item 6Ed) location with 16d nails or minimum 2-1/2 in. screws.

d. **Steel Framing Members\*** — Spaced 48 in. OC. max along truss, and secured to the truss on alternating trusses with two, #10 x 1-1/2 in. screws through mounting holes on the hanger bracket.

**PAC INTERNATIONAL L L C** — Type RSIC-SI-CRC EZ Clip

**6F. Steel Framing Members\*** — (Not Shown) — As an alternate to Item 6.

a. **Furring Channels** — Formed of No. 25 MSG galv steel, nominal 2-1/2 in. wide by 7/8 in. deep, spaced as indicated in Item 6, perpendicular to trusses and friction fit into Steel Framing Members (Item 6Fc). Ends of adjoining channels overlapped 6 in. and tied together with double strand of No. 18 SWG galv steel wire near each end of overlap or with two TEK screws along each leg of the 6 in. overlap. Two furring channels used at end joints of gypsum board (Item 7). Butt joint channels held in place by strong back channels placed upside down, on top of, and running perpendicular to primary furring channels, extending 6 in. longer than length of gypsum side joint. Strong back channels spaced maximum 48 in. OC. Strong back channels secured to every intersection of primary furring channels with four 7/16 in. pan head screws, two along each of the legs at intersections. Butt joint channels run perpendicular to strong back channels and shall be minimum 6 in. longer than length of joint, secured to strong back channels with 7/16 in. pan head screws, two along each of the legs at intersection with strong back channels.

b. **Blocking** — Where truss design does not permit direct, full contact of the hanger bracket, a piece of nominal 2 by 4 in. lumber (blocking), min. 12 in. long to permit full contact of the hanger bracket, to be secured vertically to the side of the trusses at the top and bottom of the blocking at each Steel Framing Member (Item 6Fc) location with 16d nails or minimum 2-1/2 in. screws.

c. **Steel Framing Members\*** — Used to attach furring channels (Item 6Fa) to trusses. Clips spaced 48 in. OC and secured along truss webs at each furring channel intersection with min. 3/4 in. long self-drilling #10 x 1-1/2 in. screws through each of the provided hole locations. Furring channels are friction fitted into clips.

**PAC INTERNATIONAL L L C** — Type RSIC-S1-1 Ultra

6G. **Steel Framing Members\*** — (Optional - Not Shown) — Used to attach resilient channels (Item 6) to trusses (Item 2). Clips spaced 48 in. OC and secured to trusses with one No. 8 x 2-1/2 in. coarse drywall screw through center grommet hole. Channels secured to clips with one #10 x 1/2 in. pan-head self-drilling screw. Ends of adjoining channels overlapped 6 in. and secured together with two #8 15 x 1/2 in. Philips Modified screws spaced 2-1/2 in. from the center of the overlap. Gypsum board butt joints require additional resilient channels spaced 1-1/2 in. from the butt joint on either side. One edge of the extra channels will extend to an adjacent truss where it is secured with a clip.

**KEENE BUILDING PRODUCTS CO INC** — Type RC+ Assurance Clip

6H. **Steel Framing Members\*** — (Optional, Not Shown) — Used as an alternate method to attach resilient channels to structural members. A resilient sound isolation accessory shall be used at each attachment point of the resilient channels and spaced max 24 in. O.C. Channel ends butted and centered under the structural members and attached with one accessory at each end. Additional accessories used to hold resilient channels that support the gypsum board end joints. The accessory envelops the mounting edge of the resilient channel. The accessory and resilient channel are fastened to the structural members with the screws supplied with the accessory and per the accessory manufacturer's installation instructions. Gypsum Board butt joints staggered minimum 24 in. OC and Gypsum Board screws spaced 8 in. OC when used.

**PAC INTERNATIONAL L L C** — Type RC-1 Boost

6I. **Steel Framing Members\*** — (Optional, Not Shown, As an alternate to Item 6) — Furring channels and Steel Framing Members as described below:

a. **Furring Channels** — Formed of No. 25 MSG galv steel. 2-23/32 in. wide by 7/8 in. When insulation (Item 5) is secured to the underside of the subfloor the furring channels are spaced 16 in. OC max.



When insulation (Item 5) is applied over the furring channel/gypsum panel ceiling membrane, the furring channels are spaced 12 in. OC max. Channels secured to trusses as described in Item 6lb. Ends of adjoining channels are overlapped 6 in. and tied together with double strand of No. 18 SWG galv steel wire near each end of overlap. As an alternate, ends of adjoining channels may be overlapped 6 in. and secured together with two self-tapping #6 framing screws, min. 7/16 in. long at the midpoint of the overlap, with one screw on each flange of the channel. Additional clips required to hold furring channel that supports the wallboard butt joints, as described in Item 7.

b. **Steel Framing Members\*** — Used to attach furring channels (Item 6la) to trusses (Item 2). Clips spaced 48 in. OC max with No. 8 x 2-1/2 in. course drywall screw through the center grommet. Furring channels are friction fitted into clips.

#### **CLARKDIETRICH BUILDING SYSTEMS** — Type ClarkDietrich Sound Clips

7. **Gypsum Board\*** — Nom 5/8 in. thick, 48 in. wide gypsum panels. When resilient channels (Item 6) are used, gypsum panels installed with long dimension perpendicular to resilient channels. Gypsum panels secured with 1 in. long Type S bugle head steel screws spaced 12 in. OC and located a min of 1/2 in. from side joints and 3 in. from the end joints. When insulation (Items 5 or 5A) is applied over the resilient channel/gypsum panel ceiling membrane screw spacing shall be reduced to 8 in. OC. End joints secured to both resilient channels as shown in end joint detail. When Steel Framing Members (Item 6A, 6C, 6l) are used, gypsum panels installed with long dimensions perpendicular to furring channels. Panels attached to the furring channels using 1 in. long Type S bugle-head steel screws spaced 8 in. OC along butted end joints and in the field of the panel. Butted end joints shall be staggered min. 2 ft within the assembly, and occur midway between the continuous furring channels. Each end of each gypsum panel shall be supported by a single length of furring channel equal to the width of the gypsum panel plus 6 in. on each end. The two support furring channels shall be spaced approximately 3-1/2 in. OC, and be attached to underside of the truss with one clip at each end of the channel. When **Steel Framing Members\*** (Item 6B) are used, gypsum panels installed with long dimension perpendicular to cross tees with side joints centered along main runners and end joints centered along cross tees. Panels fastened to cross tees with 1 in. long. Type S bugle-head screws spaced in the field and 8 in. OC along end joints. Panels fastened to main runners with 1 in. long. Type S bugle-head screws spaced midway between cross tees. Screws along sides and ends of panels spaced 3/8 to 1/2 in. from panel edge. End joints of panels shall be staggered with spacing between joints on adjacent panels not less than 4 2 ft OC. When **Fiber, Sprayed** (Items 5A or 5B) is used, two layers of nom 5/8 in. thick, 4 ft wide gypsum board are installed with long dimensions perpendicular to furring channels. Base layer gypsum board secured with 1 in. long Type S bugle head steel screws spaced 12 in. OC and located a min of 1/2 in. from side joints and 3 in. from the end joints. End joints secured to both resilient channels as shown in end joint detail. Outer layer gypsum board secured with 1-5/8 in. long Type S bugle head steel screws spaced 12 in. OC and located a min of 1/2 in. from side joints and 3 in. from the end joints. Outer layer shall be finished as described in Item 8. When both **Steel Framing Members** (Item 6A) and **Fiber, Sprayed** (Items 5A or 5B) are used, furring channels spaced 12 in. OC and two layers of nom 5/8 in. thick, 4 ft wide gypsum board are installed with long dimension perpendicular to furring channels. Base layer secured to furring channels with nom 1 in. long Type S bugle head screws spaced 8 in. OC along butted end joints and in the field of the board. Butted end joints shall be staggered min. 2 ft within the assembly, and occur midway between the continuous furring channels. Each end of each gypsum board shall be supported by a single length of furring channel equal to the width of the gypsum board plus 6 in.

on each end. The two support furring channels shall be spaced approximately 3-1/2 in. OC, and be attached to the underside of the truss with one RSIC-1 clip at each end of the channel. Outer layer secured to furring channels using 1-5/8 in. long Type S screws spaced 8 in. OC and 1-1/2 in. from the end joint. Butted end joints to be offset a min. of 8 in. from base layer end joints. Butted side joints of outer layer to be offset min. 18 in. from butted side joints of base layer. When **Steel Framing Members** (Item 6D) are used, one layer of nom 5/8 in. thick, 4 ft wide gypsum board is installed with long dimensions perpendicular to furring channels. Gypsum board secured to furring channels with nom 1 in. long Type S bugle-head steel screws spaced 8 in. OC in the field of the board. Gypsum board butted end joints shall be staggered minimum 48 in. and centered over main furring channels. At the gypsum board butt joints, each end of each gypsum board shall be supported by a single length of furring channel equal to the width of the gypsum board plus 3 in. on each end. The two support furring channels shall be spaced approximately 3 in. in from joint. Screw spacing along the gypsum board butt joint and along both additional channels shall be 8 in. OC. Additional screws shall be placed in the adjacent section of gypsum board into the aforementioned 3 in. extension of the extra butt joint channels as well as into the main channel that runs between. Butt joint furring channels shall be attached with one RESILMOUNT Sound Isolation Clip at each end of the channel. When **Steel Framing Members** (Item 6E) are used, nom 5/8 in. thick, 4 ft wide gypsum board, installed as described in Item 7. Adjacent butt joints staggered minimum 48 in. OC.

When **Steel Framing Members** (Item 6F) are used, nom 5/8 in. thick, 4 ft wide gypsum board, installed as described in Item 7. Butt joints staggered minimum 24 in. OC.

**CGC INC** — Types C, IP-X2, IPC-AR, ULIX.

**UNITED STATES GYPSUM CO** — Types C, IP-X2, IPC-AR, ULIX.

**USG MEXICO S A DE C V** — Types C, IP-X2, IPC-AR.

8. **Finishing System** — (Not Shown) — Vinyl, dry or premixed joint compound, applied in two coats to joints and screw-heads. Nom 2 in. wide paper tape embedded in first layer of compound over all joints. As an alternate, nom 3/32 in. thick veneer plaster may be applied to the entire surface of gypsum board.

9. **Grille** — Grille installed in accordance with the installation instructions provided with the ceiling damper.

**\* Indicates such products shall bear the UL or cUL Certification Mark for jurisdictions employing the UL or cUL Certification (such as Canada), respectively.**

Last Updated on 2023-02-21