

Design No. L568

February 4, 2022

Unrestrained Assembly Rating — 45 Min or 1 Hr (See Item 8 Table)

This design was evaluated using a load design method other than the Limit States Design Method (e.g., Working Stress Design Method). For jurisdictions employing the Limit States Design Method, such as Canada, a load restriction factor shall be used — See Guide [BXUV](#) or [BXUV7](#)

* Indicates such products shall bear the UL or cUL Certification Mark for jurisdictions employing the UL or cUL Certification (such as Canada), respectively.

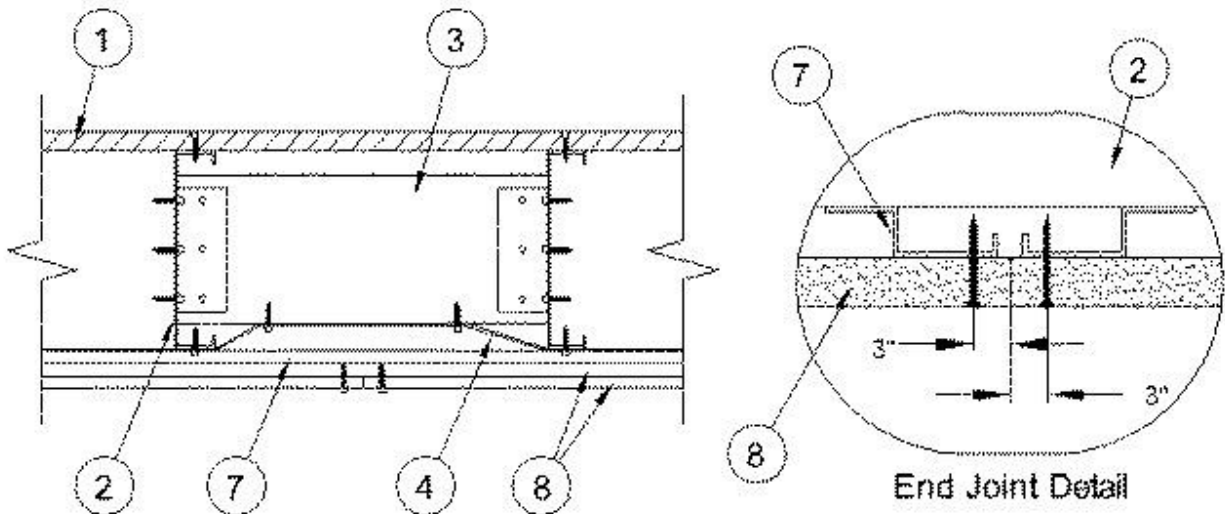

1. **Flooring System - (See Item 8 Table)** — The flooring system shall consist of the following:
System No. 1

Subflooring — Nom 5/8 in. or 3/4 in. thick plywood, min grade "C-D" or "Sheathing". Face grain of plywood to be perpendicular to joists with joints staggered. Panels secured to joists with 1-1/4 in. long No. 10 steel screws spaced 6 in. OC along joints and 12 in. OC in the field.

Finish Flooring — Nom 5/8 in. or 3/4 in. thick T & G wood structural panels, min grade "Underlayment" or "Single Floor". Face grain of panels or strength axis of panel to be perpendicular to joists with joints staggered. Panels secured to joists with 1-1/4 in. long No. 10 steel screws spaced 6 in. OC along joints and 12 in. OC in the field. If subflooring is used, screw length shall be increased to 2 in. and joints in the sub-flooring to be offset a min 16 inches from joints in the finish flooring.

System No. 2

Subflooring — Nom 5/8 in. or 3/4 in. thick plywood, min grade "C-D" or "Sheathing". Face grain of plywood to be perpendicular to joists with joints staggered. Panels secured to joists with 1-1/4 in. long No. 10 steel screws spaced 6 in. OC along joints and 12 in. OC in the field.

Vapor Barrier — (Optional) - Nom 0.010 in. thick commercial asphalt saturated felt.

Finish Flooring - Floor Topping Mixture* — Min 3/4 in. thickness of floor topping mixture having a minimum compressive strength of 1800 psi. Refer to manufacturer's instructions accompanying the material for specific mix design.

UNITED STATES GYPSUM CO — Types LRK, HSLRK, CSD

USG MEXICO S A DE C V — Types LRK, HSLRK, CSD

Floor Mat Materials* — (Optional) - Floor mat material loose laid over the subfloor. Refer to manufacturer's instructions regarding the minimum thickness of floor topping over each floor mat material.

UNITED STATES GYPSUM CO — Types SAM, LEVELROCK® Brand Sound Reduction Board, LEVELROCK® Brand Floor Underlayment SRM-25

Alternate Floor Mat Materials* — (Optional) - Nom 3/8 in. thick floor mat material loose laid over the subfloor.

GRASSWORX L L C — Type SC50

System No. 3

Subflooring — Min 15/32 in. thick wood structural panels, min grade "C-D" or "Sheathing". Face grain of plywood or strength axis of panels to be perpendicular to the joists with joints staggered.

Vapor Barrier — (Optional) - Commercial asphalt saturated felt, 0.030 in. thick.

Vapor Barrier — (Optional) - Nom 0.010 in. thick commercial rosin-sized building paper.

Finish Flooring* — Min 3/4 in. thickness of any Floor Topping Mixture bearing the UL Classification Marking as to Fire Resistance. See Floor- and Roof-Topping Mixtures (CCOX) category for names of Classified Companies. Refer to the manufacturer's instructions accompanying the material and/or contact the manufacturer's technical support for specific mix design and minimum thickness recommended for use with eligible floor mat(s).

Floor Mat Materials* — (Optional) - Nom. 1/4 in. thick loose laid over the subfloor. Floor topping thickness shall be a minimum of 3/4 in.

KEENE BUILDING PRODUCTS CO INC — Type Quiet Qurl 55/025 and Quiet Qurl 55/025 N

Alternate Floor Mat Materials* — (Optional) - Floor mat material Nom. 3/8 in. thick loose laid over the subfloor. Floor topping thickness shall be a minimum of 1 in.

KEENE BUILDING PRODUCTS CO INC — Type Quiet Qurl 60/040 and Quiet Qurl 60/040 N

Alternate Floor Mat Materials* — (Optional) - Floor mat material Nom. 3/4 in. thick loose laid over the subfloor. Floor topping thickness shall be a minimum of 1-1/2 in.

KEENE BUILDING PRODUCTS CO INC — Type Quiet Qurl 65/075, Quiet Qurl 65/075 N

Alternate Floor Mat Materials* — (Optional) - Floor mat material Nom. 1/8 in. thick loose laid over the subfloor. Floor topping thickness shall be a minimum of 3/4 in.

KEENE BUILDING PRODUCTS CO INC — Type Quiet Qurl 52/013 and Quiet Qurl 52/013 N

Alternate Floor Mat Materials* — (Optional) - Floor mat material Nom. 1/4 in. entangled net core with a compressible fabric attached to the bottom loose laid over the subfloor. Floor topping thickness shall be a minimum of 1 in.

KEENE BUILDING PRODUCTS CO INC — Quiet Qurl 55/025 MT and Quiet Qurl 55/025 N MT

2. **Steel Joist - Non-Composite Design** — The joists are channel-shaped, min 8 in. deep with min 1-5/8 in. flanges and min 9/16 in. long stiffening flanges. Joists are fabricated from min No. 18 MSG galv steel. Min yield strength of steel is 33,000 psi with corresponding max working stress of 20,000 psi. Joists spaced 16 in. OC or 24 in. OC (See Item 8 Table).

3. **Blocking** — Channel-shaped 6 in. deep with min 1-5/8 in. flanges and 9/16 in. long stiffening flanges. Blocking fabricated from min No. 18 MSG galv steel. Min yield strength of steel is 33,000 psi with corresponding max working stress of 20,000 psi. Blocking spaced max 10 ft-0 in. OC perpendicular to the joists and max 6 ft-4 in. OC along the joist length. Nom 1-1/2 by 1-1/2 by 5-1/2 in. long angle clips shall be used to connect web of steel joists to blocking with a min of six 3/4 in. long No. 8 self-tapping screws are used with each angle clip.

4. **Bridging** — Flat steel strap 2-1/16 in. wide fabricated from No. 16 MSG galv steel located max 6 ft-4 in. OC perpendicular to the joists. The flat strap is connected to the bottom flange of the steel joist with a min of one No. 8 self-tapping screw.

5. **Connecting Clip Section - (Not Shown)** — Channel-shaped 3-1/2 in. deep with min 1-5/8 in. flanges and 9/16 in. long stiffening flanges. Clips sections fabricated from No. 18 MSG galv steel. Clip sections used to fasten steel joists to joist headers. The clip section is connected using a min of six 3/4 in. long No.8 self-tapping screws at each connection.

6. **Batts and Blankets - (Not Shown, See Item 8 Table)** — Min 3-1/2 in. thickness of either mineral wool with a min density of 2.2 pcf or glass fiber with min density 0.64 pcf, fitted in the concealed space, draped over the resilient channel/gypsum board ceiling membrane. Any mineral wool or glass fiber insulation bearing the UL Classification Marking for Surface Burning Characteristics having a flame spread index of 25 or less and a smoke developed index of 50 or less may be used. See **Batts and Blankets** (BKNV) category in the Building Materials Directory for names of manufacturers.

7. **Furring Channels - (See Item 8 Table)** — Resilient channels, formed of 25 MSG galv steel, spaced 16 or 24 in. OC perpendicular to steel joists. Resilient channels secured to bottom flange of each steel joist with 3/4 in. long No. 8 Type S steel screws. Two channels, spaced 6 in. OC, oriented opposite each gypsum board end joint as shown in end joint detail. Additional channels shall extend min 9 in. beyond each side edge of board.

7A. Steel Framing Members* — (Optional, Not Shown) — As an alternate to Item 7.

a. **Furring Channels** — Formed of No. 25 MSG galv steel, nominal 2-1/2 in. wide by 7/8 in. deep, spaced 16 or 24 in. OC, perpendicular to joists. Channels secured to Cold Rolled Channels at every intersection with a 3/4 in. TEK screw through each furring channel leg. Ends of adjoining channels overlapped 12 in. and fastened together with two double strand No. 18 SWG galv steel wire ties, one at each end of overlap, or with two 3/4 in. TEK screws in each leg of the overlap section. Two furring channels used at end joints of gypsum board (Item 8), each extending a min of 6 in. beyond both side edges of the board.

b. **Cold Rolled Channels** — 1-1/2 in. by 1/2 in., formed from No. 16 ga. galv steel, positioned vertically and parallel to joists, friction-fitted into the channel caddy on the Steel Framing Members (Item 7Ac) and secured with two 3/4 in. TEK screws. Adjoining lengths of cold rolled channels lapped min. 12 in. and secured along bottom legs with four 3/4 in. TEK screws and wire-tied together with two double strand 18 SWG galv steel wire ties, one at each end of overlap.

c. **Steel Framing Members*** — Spaced 48 in. OC. max along joist, and secured to the joist on alternating joists with two, No. 10-16 TEK screws through mounting holes on the hanger bracket.

PAC INTERNATIONAL L L C — Type RSIC-SI-CRC EZ Clip

7B. Steel Framing Members* — (Optional, Not Shown) — As an alternate to Item 7.

a. **Furring Channels** — Formed of No. 25 MSG galv steel, nominal 2-1/2 in. wide by 7/8 in. deep, spaced 16 or 24 in. OC perpendicular to joists and friction fit into Steel Framing Members (Item 7Bb). Ends of adjoining channels overlapped 6 in. and tied together with double strand of No. 18 SWG galv steel wire near each end of overlap or with two TEK screws along each leg of the 6 in. overlap. Two furring channels used at end joints of gypsum board (Item 8). Butt joint channels held in place by strong back channels placed upside down, on top of, and running perpendicular to primary furring channels, extending 6 in. longer than length of gypsum side joint. Strong back channels spaced maximum 48 in. OC. Strong back channels secured to every intersection of primary furring channels with four 7/16 in. pan head screws, two along each of the legs at intersections. Butt joint channels run perpendicular to strong back channels and shall be minimum 6 in. longer than length of joint, secured to strong back channels with 7/16 in. pan head screws, two along each of the legs at intersection with strong back channels.

b. **Steel Framing Members*** — Used to attach furring channels (Item 7Ba) to joists. Clips spaced 48 in. OC and secured along joist webs at each furring channel intersection with min. 3/4 in. long self-drilling No. 10-16 TEK screws through each of the provided hole locations. Furring channels are friction fitted into clips.

PAC INTERNATIONAL L L C — Type RSIC-S1-1 Ultra

7C. Steel Framing Members* — (Optional, Not Shown) — As an alternate to Item 7.

a. **Furring Channels** — Formed of No. 25 MSG galv steel. 2-9/16 in. wide by 7/8 in. deep, spaced as described in Item 7, perpendicular to joists. Channels secured to joists as described in Item b. Ends of adjoining channels overlapped 6 in. and tied together with double strand of No. 18 SWG galv steel wire near each end of overlap.

b. **Steel Framing Members*** — Used to attach furring channels (Item a) to the steel joists (Item 2). Clips spaced a max of 48 in. OC. RSIC-1 clips secured to alternating joists with No. 8 x 1-5/8 in. fine thread screw through the center grommet. Furring channels are friction fitted into clips. Adjoining

channels are overlapped as described in Item a. As an alternate, ends of adjoining channels may be overlapped 6 in. and secured together with two self-tapping No. 6 framing screws, min. 7/16 in. long at the midpoint of the overlap, with one screw on each flange of the channel.

PAC INTERNATIONAL L L C — Type RSIC-1

8. Gypsum Board* - (See Item 8 Table) — One or two layers of nom 1/2 in. or 5/8 in. thick by 48 in. wide gypsum boards as follows:

8a. One Layer System With Resilient Channels — Gypsum board installed with long dimension perpendicular to resilient channels. Gypsum board secured to the resilient channel with 1-1/4 in. long Type S bugle head steel screws spaced 12 in. OC along butted end joints and in the field. Screws located min 1-1/2 in. from both side joints and end joints. End joints secured to both pieces of resilient channel as shown in end joint detail. Butted end joints staggered min 48 in. in adjacent rows.

8b. Two Layers System Without Resilient Channels — Base layer of gypsum board installed with long dimension perpendicular to steel joist. Gypsum board secured to steel joist with 1-1/4 in. long Type S bugle-head steel screws spaced 12 in. OC along butted end joints and in the field. Screws located min 3/8 in. from end joints and 1-1/2 in. from side joints. Base layer butted end joints staggered min 48 in. in adjacent rows. Face layer secured to steel joist through base layer with 1-1/2 in. long Type S bugle head steel screws spaced 12 in. OC. Face layer side joints offset min 24 in. from base layer side joints. Face layer end joints to be offset 36 in. from base layer end joints and shall be located between two adjacent steel joist. Face layer end joints secured to the base layer with 1-1/2 in. long Type G screws spaced max 12 in. OC and located min 1-1/2 in. from face layer end joint. When **Steel Framing Members** (Item 7A) are used, One or two layers nom 1/2 in. or 5/8 in. thick, 4 ft wide gypsum board, installed as described in Item 8. Adjacent butt joints staggered minimum 48 in. OC.

When **Steel Framing Members** (Item 7B) are used, One or two layers nom 1/2 in. or 5/8 in. thick, 4 ft wide gypsum board, installed as described in Item 8. Butt joints staggered minimum 24 in. OC.

When **Steel Framing Members** (Item 7C) are used (for use with one layer gypsum board system (Item 8a) gypsum panels installed with long dimensions perpendicular to furring channels. Panels attached to the furring channels using 1 in. long Type S bugle-head steel screws spaced 8 in. OC along butted end joints and in the field of the panel. Butted end joints shall be staggered min. 2 ft within the assembly, and occur midway between the continuous furring channels. Each end of each gypsum panel shall be supported by a single length of furring channel equal to the width of the gypsum panel plus 6 in. on each end. The two support furring channels shall be spaced approximately 3-1/2 in. OC, and be attached with one clip at each end of the channel.

CGC INC — Types C, IP-X2

UNITED STATES GYPSUM CO — Types C, IP-X2

USG BORAL DRYWALL SFZ LLC — Type C

USG MEXICO S A DE C V — Types C, IP-X2

Rating	Joist Spacing	Flooring	Insulation	Resilient Channel	Gypsum Board
45 Min.	16 in. OC	5/8 in. thick, 1 layer Subfloor and 5/8 in. thick, 1 layer Finish Floor	Mineral Wool Batt	16 in. OC	5/8 in. thick, 1 layer
	24 in. OC	3/4 in. thick, 1 layer Subfloor	Glass Fiber Batt	24 in. OC	1/2 in. thick, 2 layers
	24 in. OC	3/4 in. thick, 1 layer Subfloor	(None)	(None)	1/2 in. thick, 2 layers
1 Hour	16 in. OC	5/8 in. thick, 1 layer Subfloor	(None)	(None)	1/2 in. thick, 2 layers

8A. **Gypsum Board* (As an alternative to Item 8)** — Nom 5/8 in. thick, 48 in. wide gypsum board, installed and secured as described in Item 8 with max screw spacing 8 in. OC.

CGC INC — Type ULIX

UNITED STATES GYPSUM CO — ULIX

9. **Finishing System - (Not Shown)** — Vinyl, dry or premixed joint compound, applied in two coats to joints and screw-heads. Nom 2 in. wide paper tape embedded in first layer of compound over all joints. As an alternate, nom 3/32 in. thick veneer plaster may be applied to the entire surface of gypsum board.

*** Indicates such products shall bear the UL or cUL Certification Mark for jurisdictions employing the UL or cUL Certification (such as Canada), respectively.**

Last Updated on 2022-02-04