

# Design No. L558

April 04, 2023

**Unrestrained Assembly Rating - 1 Hr**  
**Finished Rating - 23 Min (See Items 5 or 5A)**

This design was evaluated using a load design method other than the Limit States Design Method (e.g., Working Stress Design Method). For jurisdictions employing the Limit States Design Method, such as Canada, a load restriction factor shall be used — See Guide [BXUV](#) or [BXUV7](#)

\* Indicates such products shall bear the UL or cUL Certification Mark for jurisdictions employing the UL or cUL Certification (such as Canada), respectively.

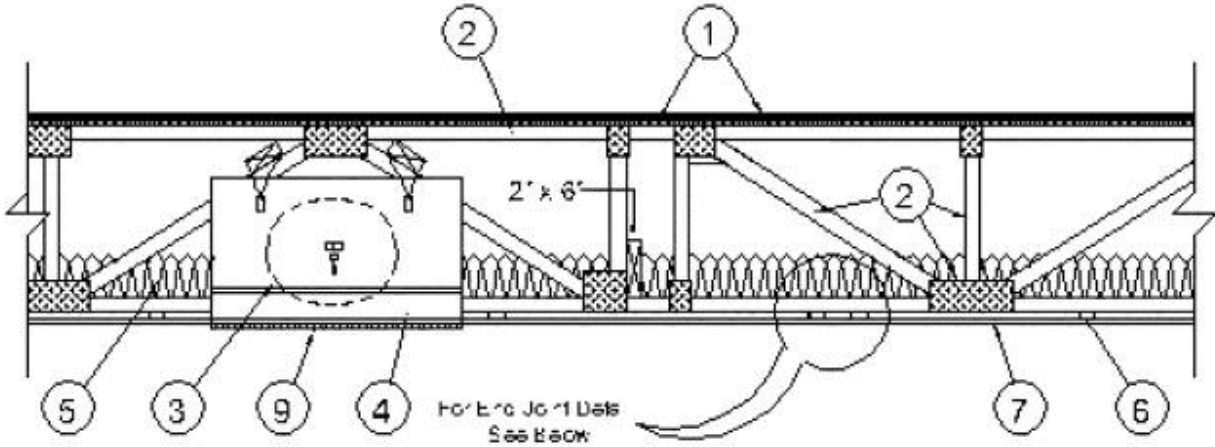

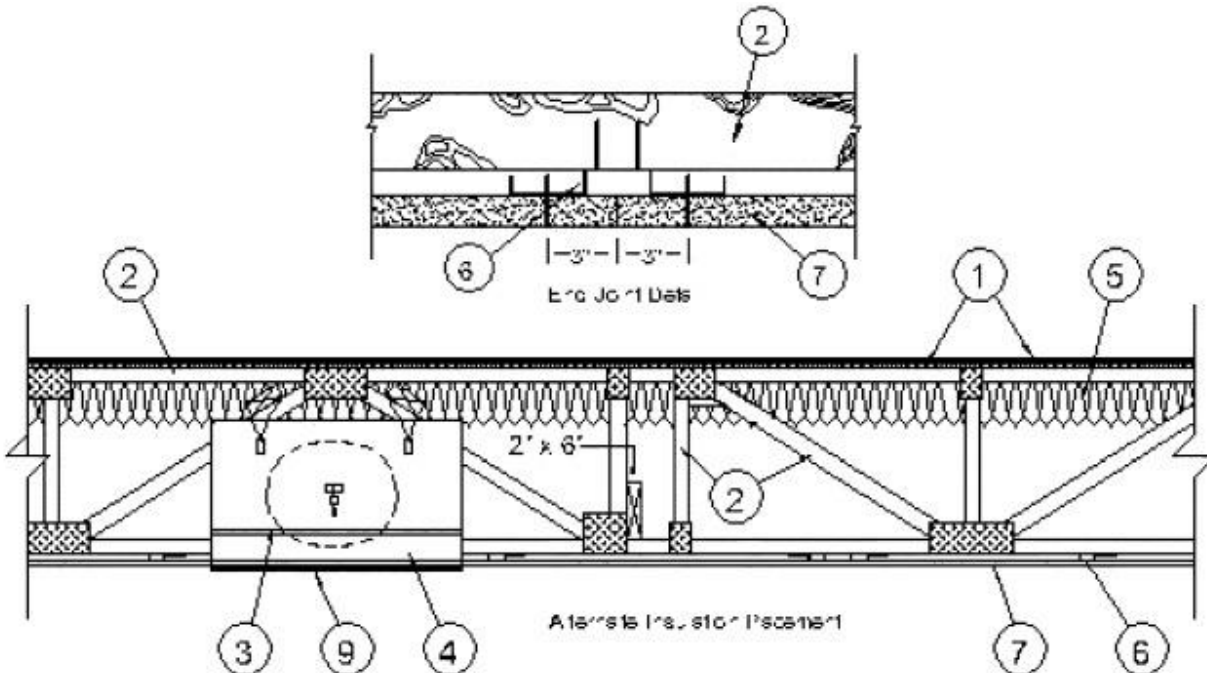

1. **Flooring System** — The flooring system shall consist of one of the following:

**System No. 1**

**Subflooring** — Min 23/32 in. thick wood structural panels installed perpendicular to trusses with end joints staggered 4 ft. Plywood or non-veneer APA rated panels secured to trusses with construction adhesive and No. 6d ringed shank nails spaced 12 in. OC along each truss. Staples having equal or greater withdrawal and lateral resistance strength may be substituted for the 6d nails.

**Vapor Barrier** — (Optional) — Nom 0.030 in. thick commercial asphalt saturated felt.

**Finish Flooring** — Min 1 by 4 in. T & G lumber fastened diagonally to trusses, or min 15/32 in. thick wood structural panels, min grade "Underlayment" or "Single-Floor". Face grain of plywood or strength axis of panel to be perpendicular to trusses with joints staggered.

**System No. 2**

**Subflooring** — Min 23/32 in. thick wood structural panels installed perpendicular to trusses with end joints staggered 4 ft. Plywood or non-veneer APA rated panels secured to trusses with construction adhesive and No. 6d ringed shank nails spaced 12 in. OC along each truss. Staples having equal or greater withdrawal and lateral resistance strength may be substituted for the 6d nails.

**Floor Mat Materials\*** — (Optional) — Floor mat material nom 5/64 in. (2 mm) thick adhered to subfloor with Hacker Floor Primer. Primer to be applied to the surface of the mat prior to the placement of a min 1 in. of floor-topping mixture.

**HACKER INDUSTRIES INC** — Type Hacker Sound-Mat.

**Alternate Floor Mat Materials** — (Optional) — Floor mat material nom 1/4 in. (6 mm) thick adhered to subfloor with Hacker Floor Primer. Primer to be applied to the surface of the mat prior to the placement of a min 1-1/4 in. (32 mm) of floor-topping mixture.

**HACKER INDUSTRIES INC** — Type Hacker Sound-Mat II.

**Alternate Floor Mat Materials** — (Optional) — Floor mat material nom 1/8 in. (3 mm) thick loose laid over the subfloor. Floor topping thickness shall be a min of 3/4 in. (19 mm)

**HACKER INDUSTRIES INC** — FIRM-FILL SCM 125

**Alternate Floor Mat Materials** — (Optional) — Floor mat material nom 1/4 in. (6 mm) thick loose laid over the subfloor. Floor topping thickness shall be a min of 1 in. (25 mm)

**HACKER INDUSTRIES INC** — Type FIRM-FILL SCM 250, Quiet Qurl 55/025

**Alternate Floor Mat Materials** — (Optional) — Floor mat material nom 3/8 in. (10 mm) thick loose laid over the subfloor. Floor topping thickness shall be a min of 1-1/4 in. (32 mm)

**HACKER INDUSTRIES INC** — FIRM-FILL SCM 400, Quiet Qurl 60/040

**Alternate Floor Mat Materials** — (Optional) — Floor mat material nom 3/8 in. (10 mm) thick loose laid over the subfloor. Floor topping thickness shall be a min of 1-1/4 in. (32 mm)

**HACKER INDUSTRIES INC** — Type FIRM-FILL SCM 750, Quiet Qurl 65/075

**Metal Lath** — (Optional) — For use with 3/8 in. (10 mm) floor mat materials, 3/8 in. expanded steel diamond mesh, 3.4 lbs/sq yd placed over the floor mat material. Hacker Floor Primer to be applied prior to the placement of the metal lath. When metal lath is used, floor topping thickness a nom 1-1/4 in. over the floor mat.

**Finish Flooring — Floor Topping Mixture\*** — Min 3/4 in. thickness of floor topping mixture having a min compressive strength of 1100 psi. Mixture shall consist of 6.8 gal of water to 80 lbs of floor topping mixture to 1.9 cu ft of sand.

**HACKER INDUSTRIES INC** — Firm-Fill Gypsum Concrete, Firm-Fill 2010, Firm-Fill 3310, Firm-Fill 4010, Firm-Fill High Strength, Gyp-Span Radiant

### **System No. 3**

**Subflooring** — Min 1 by 6 in. T & G lumber fastened diagonally to trusses, or min 15/32 in. thick plywood or min 7/16 in. thick oriented strand board (OSB) wood structural panels, min grade "C-D" or "Sheathing". Face grain of plywood or strength axis of panel to be perpendicular to trusses with joints staggered.

**Finish Floor — Mineral and Fiber Board\*** — Min 1/2 in. thick, supplied in sizes ranging from 3 ft by 4 ft to 8 ft by 12 ft. All joints to be staggered a min of 12 in. with adjacent sub-floor joints.

**HOMASOTE CO** — Type 440-32 Mineral and Fiber Board

#### **System No. 4**

**Sub-flooring** — Min 23/32 in. thick T & G wood structural panels installed perpendicular to trusses with joints staggered 4 ft. Plywood or non-veneer APA rated panels secured to trusses with construction adhesive and No. 6d ring shank nails spaced 12 in. OC along each truss. Staples having equal or greater withdrawal and lateral resistance strength may be substituted for the 6d nails.

**Vapor Barrier** — (Optional) — Nom 0.030 in. thick commercial asphalt saturated felt.

**Finish Flooring — Floor Topping Mixture\*** — Min 3/4 in. thickness of floor topping mixture having a minimum compressive strength of 1500 psi. Refer to manufacturer's instructions accompanying the material for specific mix design.

**MAXXON CORP** — Type Maxxon Standard and Maxxon High Strength

**Floor Mat Materials\*** — (Optional) — Floor mat material loose laid over the subfloor. Refer to manufacturer's instructions regarding the minimum thickness of floor topping over each floor mat material.

**MAXXON CORP** — Type Encapsulated Sound Mat.

**Floor Mat Reinforcement** — (Optional) Refer to manufacturer's instructions regarding minimum thickness of floor topping for use with floor mat reinforcement.

**Metal Lath** — (Optional) - 3/8 in. expanded galvanized steel diamond mesh, 3.4 lbs/sq yd loose laid over the floor mat material.

**Fiber Glass Reinforcement** — (Optional) - 0.015 in. thick PVC coated non-woven fiberglass mesh, 0.368 lbs./sq. yd loose laid over the floor mat material.

#### **System No. 5**

**Subflooring** — Min 23/32 in. thick wood structural panels installed perpendicular to trusses with end joints staggered 4 ft. Plywood or non-veneer APA rated panels secured to trusses with construction adhesive and No. 6d ringed shank nails spaced 12 in. OC along each truss. Staples having equal or greater withdrawal and lateral resistance strength may be substituted for the 6d nails.

**Vapor Barrier** — (Optional) Nom 0.030 in. thick commercial asphalt saturated felt.

**Finish Flooring — Floor Topping Mixture\*** — Min 3/4 in. thickness of floor topping mixture having a min compressive strength of 1000 psi. Refer to manufacturer's instructions accompanying the material for specific mix design.

**FORMULATED MATERIALS LLC** — Types FR-25, FR-30, and SiteMix

**Floor Mat Material\*** — (Optional) Floor mat material nominal 2 - 9.5 mm thick loose laid over the subfloor. Floor topping shall be a min of 1 in.

**FORMULATED MATERIALS LLC** — Types M1, M2, M3, Elite, Duo, R1, and R2

### **System No. 6**

**Subflooring** — Min 23/32 in. thick wood structural panels installed perpendicular to trusses with end joints staggered 4 ft. Plywood or non-veneer APA rated panels secured to trusses with construction adhesive and No. 6d ringed shank nails spaced 12 in. OC along each truss. Staples having equal or greater withdrawal and lateral resistance strength may be substituted for the 6d nails.

**Vapor Barrier** — (Optional) — Nom 0.030 in. thick commercial asphalt saturated felt.

**Finish Flooring — Floor Topping Mixture\*** — Min 3/4 in. thickness of floor topping mixture having a min compressive strength of 1000 psi. Refer to manufacturer's instructions accompanying the material for specific mix design.

**ARCOSA SPECIALTY MATERIALS** — AccuCrete® Types NexGen, Green, Prime and PrePour, AccuRadiant®, AccuLevel® Types G40, G50 and SD30

**Floor Mat Material\*** — (Optional) — Floor mat material nominal 2 - 9.5 mm thick loose laid over the subfloor. Floor topping shall be a min of 1 in.

**ARCOSA SPECIALTY MATERIALS** — AccuQuiet® Types D13, D-18, D25, DX38, EM.125, EM.125S, EM.250, EM.250S, EM.375, EM.375S, EM.750, and EM.750S.

### **System No. 7**

**Subflooring** — Min 23/32 in. thick wood structural panels installed perpendicular to trusses with end joints staggered 4 ft. Plywood or non-veneer APA rated panels secured to trusses with construction adhesive and No. 6d ringed shank nails spaced 12 in. OC along each truss. Staples having equal or greater withdrawal and lateral resistance strength may be substituted for the 6d nails.

**Vapor Barrier** — (Optional) — Nom 0.010 in. thick commercial asphalt saturated felt.

**Finish Flooring — Floor Topping Mixture\*** — Min 3/4 in. thickness of floor topping mixture having a minimum compressive strength of 1800 psi. Refer to manufacturer's instructions accompanying the material for specific mix design.

**UNITED STATES GYPSUM CO** — Types LRK, HSLRK, CSD

**USG MEXICO S A DE C V** — Types LRK, HSLRK, CSD

**Floor Mat Materials\*** — (Optional) — Floor mat material loose laid over the subfloor. Refer to manufacturer's instructions regarding the minimum thickness of floor topping over each floor mat material.

**UNITED STATES GYPSUM CO** — Types SAM, LEVELROCK® Brand Sound Reduction Board, LEVELROCK® Brand Floor Underlayment SRM-25

### **System No. 8**

**Subflooring** — Min 23/32 in. thick wood structural panels installed perpendicular to trusses with end joints staggered 4 ft. Plywood or non-veneer APA rated panels secured to trusses with construction adhesive and No. 6d ringed shank nails spaced 12 in. OC along each truss. Staples having equal or greater withdrawal and lateral resistance strength may be substituted for the 6d nails.

**Vapor Barrier** — (Optional) — Nom 0.030 in. thick commercial asphalt saturated felt.

**Finish Flooring — Floor Topping Mixture\*** — Min 3/4 in. thickness of floor topping mixture having a min compressive strength of 1000 psi. Refer to manufacturer's instructions accompanying the material for specific mix design.

**DEPENDABLE LLC** — Types GSL M3.4, GSL K2.6, GSL-CSD and GSL RH.

**Floor Mat Materials\*** — (Optional) — Nom. 1/4 in. thick loose laid over the subfloor. Floor topping thickness shall be a minimum of 3/4 in.

**KEENE BUILDING PRODUCTS CO INC** — Type Quiet Qurl 55/025 and Quiet Qurl 55/025 N

**Alternate Floor Mat Materials\*** — (Optional) — Floor mat material Nom. 3/8 in. thick loose laid over the subfloor. Floor topping thickness shall be a minimum of 1 in.

**KEENE BUILDING PRODUCTS CO INC** — Type Quiet Qurl 60/040 and Quiet Qurl 60/040 N

**Alternate Floor Mat Materials\*** — (Optional) — Floor mat material Nom. 3/4 in. thick loose laid over the subfloor. Floor topping thickness shall be a minimum of 1-1/2 in.

**KEENE BUILDING PRODUCTS CO INC** — Type Quiet Qurl 65/075, Quiet Qurl 65/075 N

**Alternate Floor Mat Materials\*** — (Optional) — Floor mat material Nom. 1/8 in. thick loose laid over the subfloor. Floor topping thickness shall be a minimum of 3/4 in.

**KEENE BUILDING PRODUCTS CO INC** — Type Quiet Qurl 52/013 and Quiet Qurl 52/013 N

**Alternate Floor Mat Materials\*** — (Optional) — Floor mat material Nom. 1/4 in. entangled net core with a compressible fabric attached to the bottom loose laid over the subfloor. Floor topping thickness shall be a minimum of 1 in.

**KEENE BUILDING PRODUCTS CO INC** — Quiet Qurl 55/025 MT and Quiet Qurl 55/025 N MT

#### **System No. 9**

**Subflooring** — Min 23/32 in. thick wood structural panels installed perpendicular to trusses with end joints staggered 4 ft. Plywood or non-veneer APA rated panels secured to trusses with construction adhesive and No. 6d ringed shank nails spaced 12 in. OC along each truss. Staples having equal or greater withdrawal and lateral resistance strength may be substituted for the 6d nails.

**Finish Flooring - Floor Topping Mixture\*** — Min 1 in. thickness of floor topping mixture having a min compressive strength of 4500 psi. Refer to manufacturer's instructions accompanying the material for specific mix design.

**SIKA DEUTSCHLAND GMBH** — Type SCHONOX AP Rapid Plus

#### **System No. 10**

**Subflooring** — Min 23/32 in. thick wood structural panels installed perpendicular to trusses with end joints staggered 4 ft. Plywood or non-veneer APA rated panels secured to trusses with construction adhesive and No. 6d ringed shank nails spaced 12 in. OC along each truss. Staples having equal or greater withdrawal and lateral resistance strength may be substituted for the 6d nails.

**Vapor Barrier** — (Optional) - Commercial asphalt saturated felt, 0.030 in. thick.

**Finish Flooring - Floor Topping Mixture\*** — Min 3/4 in. thickness of any Floor Topping Mixture bearing the UL Classification Marking as to Fire Resistance. See Floor- and Roof-Topping Mixtures (CCOX) category for names of Classified Companies. Refer to the manufacturer's instructions accompanying the material and/or contact the manufacturer's technical support for specific mix design and minimum thickness recommended for use with eligible floor mat(s).

**Floor Mat Materials\*** — (Optional, Not Shown) - Floor mat material loose laid over the subfloor. Refer to manufacturer's instructions regarding the minimum thickness of floor topping over each floor mat material.

**LOW & BONAR INC** — EnkaSonic® by Colbond a member of the Low & Bonar group Types 125, 250, 250 Plus, 400, 400 Plus, 750, and 750 Plus.

**Floor Mat Reinforcement** — (Optional) - Refer to manufacturer's instructions regarding minimum thickness of floor topping for use with floor mat reinforcement.

**Metal Lath** — (Optional) — Expanded steel diamond mesh, 2.5 lb / sq yd loose laid over floor mat material.

**Fiberglass Mesh Reinforcement** — (Optional) — Coated non-woven glass fiber mesh grid loose laid over floor mat material.

#### **System No. 11**



**Subflooring** — Min 23/32 in. thick T & G wood structural panels installed perpendicular to trusses with end joints staggered 4 ft. Plywood or nonveneer APA rated panels secured to trusses with construction adhesive and No. 6d ringed shank nails spaced 12 in. OC along each truss. TetraGRIP™ nails measuring 2-3/8 in. long, 0.113 in. diameter, 0.272 in. round head, and helically threaded shank with barbed features on the helix meeting ASTM F1667 and having equal or greater withdrawal and lateral resistance strength may be substituted for the 6d nails. Staples having equal or greater withdrawal and lateral resistance strength may be substituted for the 6d nails.

**Vapor Barrier - (Optional)** — Nom 0.030 in. thick commercial asphalt saturated felt.

**Finish Flooring - Floor Topping Mixture\*** — Min 1-1/2 in. thickness of floor topping mixture having a min compressive strength of 1000 psi and a cast density of 100 plus or minus 5 pcf. Foam concentrate mixed 40:1 by volume with water and expanded at 100 psi through nozzle. Mixture shall consist of 1.4 cu feet of preformed foam concentrate to 94 lbs Type I Portland cement, 300 lbs of sand with 5-1/2 gal of water.

**ELASTIZELL CORP OF AMERICA** — Type FF

### **System No. 12**

**Subflooring** — Min 23/32 in. thick T & G wood structural panels installed perpendicular to trusses with end joints staggered 4 ft. Plywood or nonveneer APA rated panels secured to trusses with construction adhesive and No. 6d ringed shank nails spaced 12 in. OC along each truss. TetraGRIP™ nails measuring 2-3/8 in. long, 0.113 in. diameter, 0.272 in. round head, and helically threaded shank with barbed features on the helix meeting ASTM F1667 and having equal or greater withdrawal and lateral resistance strength may be substituted for the 6d nails. Staples having equal or greater withdrawal and lateral resistance strength may be substituted for the 6d nails.

**Vapor Barrier - (Optional)** — Nom 0.030 in. thick commercial asphalt saturated felt.

**Finish Flooring - Floor Topping Mixture\*** — Min 1-1/2 in. thickness of floor topping mixture having a min compressive strength of 1000 psi and a cast density of 100 plus or minus 5 pcf. Foam concentrate mixed 40:1 by volume with water and expanded at 100 psi through nozzle. Mixture shall consist of 1.2 cu feet of preformed foam concentrate to 94 lbs Type I Portland cement, 300 lbs of sand with 5.5 gal of water.

**AERIX INDUSTRIES** — Floor-Topping Mixture

### **System No. 13**

**Subflooring** — Min 23/32 in. thick T & G wood structural panels installed perpendicular to trusses with end joints staggered 4 ft. Plywood or nonveneer APA rated panels secured to trusses with construction adhesive and No. 6d ringed shank nails spaced 12 in. OC along each truss. TetraGRIP™ nails measuring 2-3/8 in. long, 0.113 in. diameter, 0.272 in. round head, and helically threaded shank with barbed features on the helix meeting ASTM F1667 and having equal or greater withdrawal and lateral resistance strength may be substituted for the 6d nails. Staples having equal or greater withdrawal and lateral resistance strength may be substituted for the 6d nails.

**Finish Flooring - Floor Topping Mixture\*** — Min 3/4 in. thickness of floor topping mixture having a min compressive strength of 1000 psi. Mixture shall consist of 5 to 8 gal of water to 80 lbs of floor topping mixture to 2.1 cu ft of sand.

**ULTRA QUIET FLOORS** — Types UQF-A, UQF-Super Blend, UQF-Plus 200



## System No. 14

**Subflooring — Building Units\*** — Nom 3/4 in. thick, tongue and grooved boards. Long dimension of boards to be perpendicular to trusses with end joints staggered a min of 4 ft. and centered over the trusses. Boards secured to trusses with 2 in. long self-drilling, self-tapping screws or 2 in. x 0.113 in. Ring Shank nails spaced a max of 12 in. OC in the field with screws/nails located 1 in. from long edge, and max 8 in. OC along the end joints with screws/nails located 1/2 in. from end joint.

**ECTEK INTERNATIONAL INC** — Type MegaBoard

**Vapor Barrier - (Optional)** — Nom 0.030 in. thick commercial asphalt saturated felt.

**Finish Flooring** — Min 1 by 4 in. T & G lumber fastened diagonally to trusses, or min 15/32 in. thick wood structural panels, min grade "Underlayment" or "Single Floor". Face grain of plywood or strength axis of panel to be perpendicular to trusses with joints staggered.

2. **Trusses** — Parallel chord trusses, spaced a max of 24 in. OC, fabricated from nom 2 by 4 lumber, with lumber oriented vertically or horizontally. Min truss depth is 12 in. when Ceiling Dampers\* are not used. Min truss depth is 18 in. when Ceiling Damper\* is used. Truss members secured together with min 0.036 0356 in. thick galvanized steel plates. Plates have 5/16 in. long teeth projecting perpendicular to the plane of the plate. The teeth are in pairs facing each other (made by the same punch), forming a split tooth type plate. Each tool has a chisel point on its outside edge. These points are diagonally opposite each other for each pair. The top half of each tooth has a twist for stiffness. The pairs are repeated on approx. 7/8 in. centers with four rows of teeth per inch of plate width.

3. **Air Duct\*** — (Optional) — Any UL Class 0 or Class 1 flexible air duct installed in accordance with the instructions provided by the damper manufacturer.

4. **Ceiling Damper\*** — (Optional. To be used with Air Duct Item 3.) — Max nom area shall be 324 sq in. Max square size shall be 18 in. by 18 in. Rectangular sizes not to exceed 324 sq in. with a max width of 18 in. Max height of damper shall be 14 in. Aggregate damper openings shall not exceed 162 sq in. per 100 sq ft of ceiling area. Damper installed in accordance with the manufacturer's installation instructions provided with the damper. A steel grille (Item 9) shall be installed in accordance with installation instructions.

**C&S AIR PRODUCTS** — Model RD-521.

**POTTORFF** — Model CFD-521.

4A. **Alternate Ceiling Damper\*** — (Optional. To be used with Air Duct Item 3.) — Max nom area shall be 256 sq in. with the length not to exceed 24 in. and the width not to exceed 20 in. Max height of damper shall be 17 in. Aggregate damper openings shall not exceed 128 sq in. per 100 sq ft of ceiling area. Damper installed in accordance with the manufacturer's installation instructions provided with the damper. A steel grille (Item 9) shall be installed in accordance with installation instructions.

**C&S AIR PRODUCTS** — Model RD-521-IP, RD-521-NP

**POTTORFF** — Models CFD-521-IP, CFD-521-NP

**4B. Alternate Ceiling Damper\*** — For use with min 18 in. deep trusses. Max nom area shall be 144 sq in. with the length not to exceed 14 in. and the width not to exceed 12 in. Max height of damper shall be 17-7/8 in. Aggregate damper openings shall not exceed 74 sq in. per 100 sq ft of ceiling area. Damper installed in accordance with the manufacturers installation instructions provided with the damper. A steel grille (Item 9) shall be installed in accordance with installation instructions.

**C&S AIR PRODUCTS** — Model RD-521-90, RD-521-NP90

**POTTORFF** — Models CFD-521-90, CFD-521-90NP

**4C. Alternate Ceiling Damper\*** — (Optional. To be used with Air Duct Item 3.) — Max. nom area shall be 349 sq in. Max. overall length and width shall not exceed 18-11/16 in. by 18-11/16 in. with max. 16 in. by 16 in. register opening. Aggregate damper openings shall not exceed 175 sq in. per 100 sq ft of ceiling area. Damper installed in accordance with the manufacturer's installation instructions provided with the damper. An aluminum or steel grille (Item 9) shall be installed in accordance with installation instructions.

**MIAMI TECH INC** — Model Series RxCRD, RxCRDS or RxCRPD

**4D. Alternate Ceiling Damper\*** — (Optional. To be used with Air Duct Item 3.) For use with min 18 in. deep trusses — Max plenum box size nom 19 in. long by 19 in. wide and 11-7/8 in. high fabricated from galv steel. Aggregate damper openings shall not exceed 128 sq in. per 100 sq ft of ceiling area. Damper installed in accordance with the manufacturers installation instructions provided with the damper.

**AIRE TECHNOLOGIES INC** — Models: CRD model 50 w/Boot, CRD model 50EA w/Boot, CRD model 55 w/Boot, CRD model 55 EA w/Boot.

**LLOYD INDUSTRIES INC** — Model CRD 50-BT, CRD 50-EA-BT, CRD 55-BT, CRD 55 EA-BT

**4E. Alternate Ceiling Damper\*** — Max plenum box size nom 13 in. long by 13 in. wide and 11-7/8 in. high fabricated from galv steel. Aggregate damper openings shall not exceed 50 sq in. per 100 sq ft of ceiling area. Damper installed in accordance with the manufacturers installation instructions provided with the damper.

**LLOYD INDUSTRIES INC** — Model CRD 50-BT-6, CRD 50-EA-BT-6, CRD 55-BT-6, CRD 55 EA-BT-6, CRD50-w X-BT-6

**4F. Alternate Ceiling Damper\*** — (Optional. To be used with Air Duct Item 3.) For use with min 18 in. deep trusses. Max size ceiling outlet in plenum box nom 12 in. long by 12 in. wide. Plenum box fabricated from galv steel. Aggregate damper openings shall not exceed 72 sq in. per 100 sq ft of ceiling area. Installed in accordance with the manufacturers installation instructions provided with the damper.

**AIRE TECHNOLOGIES INC** — Models: CRD model 50 w/Boot, CRD model 50EA w/Boot, CRD model 55 w/Boot, CRD model 55 EA w/Boot.

**LLOYD INDUSTRIES INC** — Model CRD 50-95BT, CRD 50-EA-95BT, CRD 55-95BT, CRD 55 EA-95BT

**4G. Alternate Ceiling Damper\*** — Max size ceiling outlet in plenum box nom 16 in. long by 16 in. wide. Aggregate damper openings shall not exceed 128 sq in. per 100 sq ft of ceiling area. Damper installed in accordance with the manufacturers installation instructions provided with the damper.  
**CROWN PRODUCTS CO INC** — Models CRD50-FGPB-4.2-CP, -6.0-CP; CRD50-FGPB-4.2-EA-CP, -6.0-EA-CP

**LLOYD INDUSTRIES INC** — Models CRD 50- FGPB-4.2, - 4.2 NI, -6.0, -6.0 NI; CRD50-EA-FGPB-4.2, - 4.2 NI, -6.0, -6.0 NI

**4H. Alternate Ceiling Damper\*** — Max plenum box size nom 15 in. long by 15 in. wide and 11-7/8 in. high fabricated from galv steel. Aggregate damper openings shall not exceed 72 sq in. per 100 sq ft of ceiling area. Damper installed in accordance with the manufacturers installation instructions provided with the damper.

**LLOYD INDUSTRIES INC** — Models 45-CRD-LT-BT and 45-CRD-LTD-BT

**4I. Alternate Ceiling Damper\*** — Max size ceiling outlet in plenum box nom 10 in. long by 10 in. wide. Plenum box fabricated from galv steel. Aggregate damper openings shall not exceed 50 sq in. per 100 sq ft of ceiling area. Installed in accordance with the manufacturers installation instructions provided with the damper.

**LLOYD INDUSTRIES INC** — Model 45-LTD-95-BT-4

**4J. Alternate Ceiling Damper\*** — Max plenum box size nom 19 in. long by 15 in. wide and 11-7/8 in. high fabricated from galv steel. Aggregate damper openings shall not exceed 96 sq in. per 100 sq ft of ceiling area. Damper installed in accordance with the manufacturers installation instructions provided with the damper.

**LLOYD INDUSTRIES INC** — Model CRD50-w X-BT

**4K. Alternate Ceiling Damper\*** — Ceiling damper & fan assembly. Max nom area shall be 75 sq in. with the length not to exceed 8-9/16 in. and the width not to exceed 8-3/4 in. Max height of damper shall be 9-7/8 in. Aggregate damper openings shall not exceed 38 sq in. per 100 sq ft of ceiling area. Damper shall be installed in combination with one of the fan models described in, and in accordance with, the manufacturers installation instructions provided with the damper. A plastic grille (Item 9) shall be installed in accordance with installation instructions.

**DELTA ELECTRONICS INC** — Models CRD2, GBR-CRD, ITG-CRD

**4L. Alternate Ceiling Damper\*** — (Optional. To be used with Air Duct Item 3.) — Max nom area shall be 324 sq in. Max square size shall be 18 in. by 18 in. Rectangular sizes not to exceed 324 sq in. with a max length of 20 in. and a max width of 22 in. Max height of damper shall be 14 in. Aggregate damper openings shall not exceed 154 sq in. per 100 sq ft of ceiling area. Damper installed in accordance with the manufacturer's installation instructions provided with the damper. An aluminum or steel grille (Item 9) shall be installed in accordance with installation instructions.

**UNITED ENERTECH CORP** — Type C-S/R-WT or C-S/R-WTP (Max nom area 324 sq. in.) or C-S/R-WTS or C-S/R-WTPS (Max nom area 162 sq. in.)

**4M. Alternate Ceiling Damper\*** — (Optional. To be used with Air Duct Item 3.) — Max damper assembly size nom 18 in. long by 18 in. wide and 4-1/4 in. high, or 8 in. diam. fabricated from galv

steel. Aggregate damper openings shall not exceed 162 sq in. per 100 sq ft of ceiling area. Damper installed in accordance with the manufacturers installation instructions provided with the damper.

**RUSKIN COMPANY** — Model CFD7T , CFD7T-END-BT, CFD7T-90-BT, CFD7T-ST-BT, CFD7T-SB, CFD7T-R6-DB, CFD7T-IB6, or CFDR7T

**4N. Alternate Ceiling Damper\*** — Ceiling damper & fan assembly for use with min 18 in. deep trusses. Max nom area shall be 75 sq in. with the length not to exceed 9-1/4 in. and the width not to exceed 9-3/4 in. Max height of damper shall be 9-7/8 in. Aggregate damper openings shall not exceed 45 sq in. per 100 sq ft of ceiling area. Damper shall be installed in combination with one of the fan models described in, and in accordance with, the manufacturer's installation instructions provided with the damper. A plastic grille (Item 9) shall be installed in accordance with installation instructions.

**DELTA ELECTRONICS INC** — Model SIG-CRD

**4O. Alternate Ceiling Damper\*** — Ceiling damper & fan assembly for use with min 18 in. deep trusses. Max nom area shall be 103 sq in. with the length not to exceed 10-1/8 in. and the width not to exceed 10-1/8 in. Aggregate damper openings shall not exceed 52 sq in. per 100 sq ft of ceiling area. Damper shall be installed in combination with one of the fan models described in, and in accordance with, the manufacturer's installation instructions provided with the damper. A plastic grille (Item 9) shall be installed in accordance with installation instructions.

**DELTA ELECTRONICS INC** — Model SMT-CRD

**4P. Alternate Ceiling Damper\*** — Ceiling damper & fan assembly for use with min 18 in. deep trusses. Max nom area shall be 131 sq in. with the length not to exceed 11-1/16 in. and the width not to exceed 11-7/8 in. Aggregate damper openings shall not exceed 66 sq in. per 100 sq ft of ceiling area. Damper shall be installed in combination with one of the fan models described in, and in accordance with, the manufacturer's installation instructions provided with the damper. A plastic grille (Item 9) shall be installed in accordance with installation instructions.

**PANASONIC CORPORATION, PANASONIC CORPORATION OF NORTH AMERICA** — Model PC-RD05C5

**4Q. Alternate Ceiling Damper\*** — Ceiling damper & fan assembly for use with min 18 in. deep trusses. Max nom area shall be 113 sq in. with the length not to exceed 10-1/8 in. and the width not to exceed 11-1/8 in. Aggregate damper openings shall not exceed 57 sq in. per 100 sq ft of ceiling area. Damper shall be installed in combination with one of the fan models described in, and in accordance with, the manufacturer's installation instructions provided with the damper. A plastic grille (Item 9) shall be installed in accordance with installation instructions.

**BROAN-NUTONE L L C** — Model RDFUWT

**4R. Alternate Ceiling Damper\*** — Ceiling damper & fan assembly for use with min 18 in. deep trusses. Max nom area shall be 79 sq in. with the length not to exceed 10 in. and the width not to exceed 7-15/16 in. Aggregate damper openings shall not exceed 40 sq in. per 100 sq ft of ceiling area. Damper shall be installed in combination with one of the fan models described in, and in accordance with, the manufacturer's installation instructions provided with the damper. A metallic grille (Item 9) shall be installed in accordance with installation instructions.

**BROAN-NUTONE L L C** — Models RDJ1 and RDH

4S. **Alternate Ceiling Damper\*** — For use with min 18 in. deep trusses Max plenum box size nom 19 in. long by 19 in. wide and 11-7/8 in. high fabricated from galv steel. Aggregate damper openings shall not exceed 128 sq in. per 100 sq ft of ceiling area. Damper installed in accordance with the manufacturers installation instructions provided with the damper.

**METAL-FAB INC** — Models MSCD-HC and MRCD-HC

4T. **Alternate Ceiling Damper\*** — Ceiling damper & fan assembly for use with min 18 in. deep trusses. Max nom area shall be 87 sq in. with the length not to exceed 9 in. and the width not to exceed 9-11/16 in. Aggregate damper openings shall not exceed 44 sq in. per 100 sq ft of ceiling area. Damper shall be installed in combination with one of the fan models described in, and in accordance with, the manufacturer's installation instructions provided with the damper. A plastic grille (Item 9) shall be installed in accordance with installation instructions.

**BROAN-NUTONE L L C** — Model RDMWT

4U. **Alternate Ceiling Damper\*** — Ceiling damper & fan assembly for use with min 18 in. deep trusses. Max nom area shall be 87 sq in. with the length not to exceed 9 in. and the width not to exceed 9-11/16 in. Aggregate damper openings shall not exceed 44 sq in. per 100 sq ft of ceiling area. Damper shall be installed in combination with one of the fan models described in, and in accordance with, the manufacturer's installation instructions provided with the damper. A plastic grille (Item 9) shall be installed in accordance with installation instructions.

**BROAN-NUTONE L L C** — Model RDMWT2

4V. **Alternate Ceiling Damper\*** — (Optional, To be used with Air Duct Item 3) — For use with min 18 in. deep trusses. Max nom 21 in. long by 18 in. wide, fabricated from galvanized steel. Plenum box max size nom 21 in. long by 18 in. wide by 14 in. high (inner dimension) fabricated from either galvanized steel or min 1 in. thick Listed Duct Board bearing the UL Listing Marking having a min R-Value of 4.3. Installed in accordance with the instructions provided by the manufacturer. Max damper openings not to exceed 180 sq in. per 100 sq ft of ceiling area.

**GREENHECK FAN CORP** — Model CRD-1WT

4W. **Alternate Ceiling Damper\*** — (Optional, to be used with Air Duct Item 3) — For use with min 18 in. deep trusses. Max nom 12 in. long by 12 in. wide with an 8 in. diameter damper, fabricated from galvanized steel. Installed in accordance with the instructions provided by the manufacturer. Max damper openings not to exceed 72 sq in. per 100 sq ft of ceiling area.

**GREENHECK FAN CORP** — Model CRD-2WT

4X. **Alternate Ceiling Damper\*** — (Optional. To be used with Air Duct Item 3.) For use with min 18 in. deep trusses. Max 12 in. diameter damper and insulated register box assembly. The maximum size of the register box assembly is nom. 20 in. long by 20 in. wide and 4 in. high fabricated from galv steel. The aggregate area of the register opening(s) through the ceiling membrane shall not exceed 128 sq in. per 100 sq ft of ceiling area. Damper assembly installed in accordance with the manufacturers installation instructions.

**AIRE TECHNOLOGIES INC** — Model 571B.

4Y. **Alternate Ceiling Damper\*** — (Optional. To be used with Air Duct Item 3.) For use with min 18 in. deep trusses. Max 20 in. long by 16 in. wide by 4 in. high rectangular damper with plenum box assembly. The maximum outer dimensions of the plenum box assembly is 23-1/2 in. long by 19-1/2 in. wide and 17 in. high fabricated from 6pcf, 1-1/2 to 2 in. thick Knauf Air Duct Board M\*. The

aggregate area of the register opening(s) through the ceiling membrane shall not exceed 160 sq in. per 100 sq ft ceiling area. Damper assembly installed in accordance with the manufacturers installation instructions.

**AIRE TECHNOLOGIES INC** — Series 58.

**4Z. Alternate Ceiling Damper\*** — (Optional. To be used with Air Duct Item 3.) For use with min 18 in. deep trusses. Max 14 in. long by 14 in. wide and 18 in. high ceiling damper with boot or box assembly, fabricated from galv steel. The aggregate area of the register opening(s) through the ceiling membrane shall not exceed 98 sq in. per 100 sq ft of ceiling area. Damper assembly installed in accordance with the manufacturers installation instructions.

**AIRE TECHNOLOGIES INC** — Model 51 w/Boot.

**4AA. Alternate Ceiling Damper\*** — (Optional, to be used with Air Duct Item 3) For use with min 18 in. deep trusses. Max nom 11-1/8 in. long by 13-5/8 in. wide, fabricated from galvanized steel. Installed in accordance with the instructions provided by the manufacturer. Max damper openings not to exceed 76 sq in. per 100 sq ft of ceiling area.

**GREENHECK FAN CORP** — Model CRD-310WT

**4AB. Alternate Ceiling Damper\*** — (Optional, to be used with Air Duct Item 3) For use with min 18 in. deep trusses. Max nom 12-3/8 in. long by 14-1/2 in. wide, fabricated from galvanized steel. Installed in accordance with the instructions provided by the manufacturer. Max damper openings not to exceed 90 sq in. per 100 sq ft of ceiling area.

**GREENHECK FAN CORP** — Model CRD-320WT

**4AC. Alternate Ceiling Damper\*** — (Optional, to be used with Air Duct Item 3) For use with min 18 in. deep trusses. Max 12 in. diameter damper within max 15 in. by 15 in. register box with max 12 in. by 12 in. register opening fabricated from galvanized steel. Aggregate area of the register opening(s) through the ceiling membrane shall not exceed 72 sq. in. per 100 sq. ft. of ceiling area. Damper assembly installed in accordance with the manufacturer's installation instructions.

**RUSKIN COMPANY** — Model CFD7T-SR

**4AD. Alternate Ceiling Damper\*** — (Optional. To be used with Air Duct Item 3.) For use with min 18 in. deep trusses. Max 12 in. diameter damper and insulated register box assembly. The maximum size of the register box assembly is nom. 20 in. long by 20 in. wide and 4 in. high fabricated from galv steel. The aggregate area of the register opening(s) through the ceiling membrane shall not exceed 128 sq in. per 100 sq ft of ceiling area. Damper assembly installed in accordance with the manufacturers installation instructions.

**SOUTHWARK METAL MFG CO** — Model 800 w/Box

**4AE. Alternate Ceiling Damper\*** — (Optional. To be used with Air Duct Item 3.) For use with min 18 in. deep trusses. Max 20 in. long by 16 in. wide by 4 in. high rectangular damper with plenum box assembly. The maximum outer dimensions of the plenum box assembly are 23-1/2 in. long by 19-1/2 in. wide and 17 in. high fabricated from 6pcf, 1-1/2 to 2 in. thick Knauf Air Duct Board M\*. The aggregate area of the register opening(s) through the ceiling membrane shall not exceed 160 sq in. per 100 sq ft ceiling area. Damper assembly installed in accordance with the manufacturers installation instructions.

**SOUTHWARK METAL MFG CO** — CRD w/DB Box



**4AF. Alternate Ceiling Damper\*** — (Optional. To be used with Air Duct Item 3.) For use with min 18 in. deep trusses. Max 14 in. long by 14 in. wide and 18 in. high ceiling damper with boot or box assembly, fabricated from galv steel. The aggregate area of the register opening(s) through the ceiling membrane shall not exceed 98 sq in. per 100 sq ft of ceiling area. Damper assembly installed in accordance with the manufacturers installation instructions.

**SOUTHWARK METAL MFG CO** — Model 500 w/Boot, 510 w/Boot, 500 w/Box or 510 w/Box

**4AG. Alternate Ceiling Damper\*** — (Optional, to be used with Air Duct Item 3) For use with min 18 in. deep trusses. Max nom 10-3/8 in. long by 10-3/8 in. wide, fabricated from galvanized steel. Installed in accordance with the instructions provided by the manufacturer. Max damper openings not to exceed 54 sq in. per 100 sq ft of ceiling area.

**GREENHECK FAN CORP** — Model CRD-300WT

**4AH. Alternate Ceiling Damper\*** — (Optional. To be used with Air Duct Item 3.) — For use with min 18 in. deep trusses. For use with Item 4D only. Not for use with flooring system 1. Maximum 20 in. long by 18 in. wide by 2-1/8 in. high, fabricated from galvanized steel. Plenum box maximum size nom. 21 in. long by 18 in. wide by 16 in. high fabricated from either galvanized steel or Classified Air Duct Materials bearing the UL Class 0 or Class 1 rigid air duct material. Installed in accordance with the instructions provided by the manufacturer. Max damper openings not to exceed 180 sq in. per 100 sq ft of ceiling area.

**NAILOR INDUSTRIES INC** — Types 0756, 0756D, 0757, 0757D, 0757FP, 0757DFP, 0763

**SAFE AIR DOWCO** — 0456, 0456D, 0457, 0457D, 0457-DB, 0457-CB, 0463-FB, 0457-EB, 0463-GB, 0463

**5. Batts and Blankets\*** — (Optional) - Glass fiber or mineral wool insulation bearing the UL Classification Marking as to Surface Burning Characteristics and/or Fire Resistance. When no insulation is installed in the concealed space resilient channels (Item 6) are spaced 24 in. OC. When the resilient channels (Item 6) are spaced 16 in. OC, the insulation shall be a max of 3-1/2 in. thick, and shall be secured against the subflooring with staples at 12 in. OC or held suspended in the concealed space with 0.090 in. diam galv steel wires attached to the wood trusses at 12 in. OC. When the resilient channels are spaced a max of 12 in. OC or when the Steel Framing Members (Item 6A) are used, there is no limit in the overall thickness of insulation, and the insulation can be secured against the subflooring, held suspended in the concealed space or draped over the resilient channels (or Steel Framing Members) and gypsum panel membrane. The finished rating has only been determined when the insulation is secured to the subflooring.

**5A. Loose Fill Material\* or Sprayed Fiber\*** — Loose fill material or sprayed fiber may be used as an alternate to batt insulation (Item 5). Any loose fill material bearing the UL Classification Marking for Surface Burning Characteristics, having a min density of 0.5 pcf and installed at a max thickness of 3-1/2 in. may be used. No limit on maximum thickness when used with Item 7A. The finished rating when loose fill material is used has not been determined.

**5B. Batts and Blankets\*** — For use with 7A and 6E-Glass fiber or mineral wool insulation bearing the UL Classification Marking as to Surface Burning Characteristics and/or Fire Resistance. The insulation shall be a minimum of 3-1/2 in. thick, there is no limit on maximum thickness of insulation. Insulation draped over the resilient channels and gypsum panel membrane.



**6. Resilient Channels** — Resilient channels formed of 25 MSG thick galv steel, spaced 16 in. OC, installed perpendicular to trusses. When batt and blanket material, Item 5, is draped over the resilient channel/gypsum wallboard ceiling membrane or Item 5A is used, the spacing shall be 12 in. OC. Channels secured to each truss with 1-1/4 in. long Type S bugle head steel screws. Channels overlapped 4 in. at splices. Two channels, spaced 6 in. OC, oriented opposite each gypsum board end joint as shown in the above illustration. Additional channels shall extend min 6 in. beyond each side edge of board.

**6A. Steel Framing Members\*** — (Optional, Not Shown) — As an alternate to Item 6.

a. **Furring Channels** — Formed of No. 25 MSG galv steel, nominal 2-1/2 in. wide by 7/8 in. deep, spaced 12 in. OC, perpendicular to the trusses. Channels secured to Cold Rolled Channels at every intersection with a 3/4 in. TEK screw through each furring channel leg. Ends of adjoining channels overlapped 12 in. and fastened together with two double strand No. 18 SWG galv steel wire ties, one at each end of overlap, or with two 3/4 in. TEK screws in each leg of the overlap section. Two furring channels used at end joints of gypsum board (Item 7), each extending a min of 6 in. beyond both side edges of the board.

b. **Cold Rolled Channels** — 1-1/2 in. by 1/2 in., formed from No. 16 ga. galv steel, positioned vertically and parallel to trusses, friction-fitted into the channel caddy on the Steel Framing Members (Item 6Ad) and secured with two 3/4 in. TEK screws. Adjoining lengths of cold rolled channels lapped min. 12 in. and secured along bottom legs with four 3/4 in. TEK screws and wire-tied together with two double strand 18 SWG galv steel wire ties, one at each end of overlap.

c. **Blocking** — Where truss design does not permit direct, full contact of the hanger bracket, a piece of nominal 2 by 4 in. lumber (blocking), min. 12 in. long to permit full contact of the hanger bracket, to be secured vertically to the side of the trusses at the top and bottom of the blocking at each Steel Framing Member (Item 6Ad) location with 16d nails or minimum 2-1/2 in. screws.

d. **Steel Framing Members\*** — Spaced 48 in. OC. max along truss, and secured to the truss on alternating trusses with two, #10 x 1-1/2 in. screws through mounting holes on the hanger bracket.

**PAC INTERNATIONAL L L C** — Type RSIC-SI-CRC EZ Clip

**6B. Steel Framing Members\*** — (Not Shown) — As an alternate to Item 6.

a. **Furring Channels** — Formed of No. 25 MSG galv steel, nominal 2-1/2 in. wide by 7/8 in. deep, spaced 12 in. OC perpendicular to trusses and friction fit into Steel Framing Members (Item 6Bc). Ends of adjoining channels overlapped 6 in. and tied together with double strand of No. 18 SWG galv steel wire near each end of overlap or with two TEK screws along each leg of the 6 in. overlap. Two furring channels used at end joints of gypsum board (Item 7). Butt joint channels held in place by strong back channels placed upside down, on top of, and running perpendicular to primary furring channels, extending 6 in. longer than length of gypsum side joint. Strong back channels spaced maximum 48 in. OC. Strong back channels secured to every intersection of primary furring channels with four 7/16 in. pan head screws, two along each of the legs at intersections. Butt joint channels run perpendicular to strong back channels and shall be minimum 6 in. longer than length of joint, secured to strong back channels with 7/16 in. pan head screws, two along each of the legs at intersection with strong back channels.

b. **Blocking** — Where truss design does not permit direct, full contact of the hanger bracket, a piece of nominal 2 by 4 in. lumber (blocking), min. 12 in. long to permit full contact of the hanger bracket,

to be secured vertically to the side of the trusses at the top and bottom of the blocking at each Steel Framing Member (Item 6Bc) location with 16d nails or minimum 2-1/2 in. screws.

c. **Steel Framing Members\*** — Used to attach furring channels (Item 6Ba) to trusses. Clips spaced 48 in. OC and secured along truss webs at each furring channel intersection with min. 3/4 in. long self-drilling #10 x 1-1/2 in. screws through each of the provided hole locations. Furring channels are friction fitted into clips.

**PAC INTERNATIONAL L L C** — Type RSIC-S1-1 Ultra

6C. **Steel Framing Members\*** — (Optional - Not Shown) — Used to attach resilient channels (Item 6) to trusses (Item 2). Clips spaced 48 in. OC and secured to trusses with one No. 8 x 2-1/2 in. coarse drywall screw through center grommet hole. Channels secured to clips with one #10 x 1/2 in. pan-head self-drilling screw. Ends of adjoining channels overlapped 6 in. and secured together with two #8 15 x 1/2 in. Philips Modified screws spaced 2-1/2 in. from the center of the overlap. Gypsum board butt joints require additional resilient channels spaced 1-1/2 in. from the butt joint on either side. One edge of the extra channels will extend to an adjacent truss where it is secured with a clip.

**KEENE BUILDING PRODUCTS CO INC** — Type RC+ Assurance Clip

6D. **Steel Framing Members\*** — (Not Shown) As an alternate to Item 6, furring channels and Steel Framing Members\* as described below:

a. **Furring Channels** — Formed of No. 25 MSG galv steel, 2-9/16 in. wide by 7/8 in. deep, spaced as described in item 6 perpendicular to trusses. Channels secured to trusses as described in Item b. Ends of adjoining channels overlapped 6 in. and tied together with double strand of No. 18 SWG galv steel wire near each end of overlap.

b. **Steel Framing Members\*** — Used to attach furring channels (Item a) to trusses (Item 2). Clips spaced 48 in. OC. RSIC-1 clips secured to alternating trusses with No. 8 x 2-1/2 in. coarse drywall screw through the center grommet. Furring channels are friction fitted into clips. RSIC-1 clips for use with 2-9/16 in. wide furring channels. Adjoining channels are overlapped as described in Item a. As an alternate, ends of adjoining channels may be overlapped 6 in. and secured together with two self-tapping No. 6 framing screws, min 7/16 in. long at the midpoint of the overlap, with one screw on each flange of the channel.

**PAC INTERNATIONAL L L C** — Type RSIC-1

6E. **Resilient Channels** — For use with item 7A and 5B-Formed from min 25 MSG galv steel installed perpendicular to trusses, spaced 16 in. OC. Channels secured to each truss with 1-1/4 in. long Type S bugle head steel screws. Channels overlapped 4 in. at splices. Two channels, spaced 6 in. OC, oriented opposite each gypsum panel end joint as shown in the above illustration. Additional channels shall extend min 6 in. beyond each side edge of panel.

6F. **Steel Framing Members\*** — (Optional, Not Shown) — Used as an alternate method to attach resilient channels to structural members. A resilient sound isolation accessory shall be used at each attachment point of the resilient channels and spaced max 24 in. O.C. Channel ends butted and centered under the structural members and attached with one accessory at each end. Additional accessories used to hold resilient channels that support the gypsum board end joints. The accessory envelops the mounting edge of the resilient channel. The accessory and resilient channel are fastened to the structural members with the screws supplied with the accessory and per the

accessory manufacturer's installation instructions. Gypsum Board butt joints staggered minimum 24 in. OC and Gypsum Board screws spaced 8 in. OC when used.

**PAC INTERNATIONAL L L C** — Type RC-1 Boost

**6G. Steel Framing Members\*** — (Optional, Not Shown, As an alternate to Item 6) — Furring channels and Steel Framing Members as described below:

a. **Furring Channels** — Formed of No. 25 MSG galv steel. 2-23/32 in. wide by 7/8 in. When there is no insulation installed in the concealed space the furring channels are spaced 24 in. OC max perpendicular to trusses. When insulation (Item 5) is secured to the underside of the subfloor the furring channels are spaced 16 in. OC max. When insulation (Item 5) is applied over the furring channel/gypsum panel ceiling membrane, the furring channels are spaced 12 in. OC max. Channels secured to trusses as described in Item 6Gb. Ends of adjoining channels are overlapped 6 in. and tied together with double strand of No. 18 SWG galv steel wire near each end of overlap. As an alternate, ends of adjoining channels may be overlapped 6 in. and secured together with two self-tapping #6 framing screws, min. 7/16 in. long at the midpoint of the overlap, with one screw on each flange of the channel. Additional clips required to hold furring channel that supports the wallboard butt joints, as described in Item 7.

b. **Steel Framing Members\*** — Used to attach furring channels (Item 6Ga) to trusses (Item 2). Clips spaced 48 in. OC max with No. 8 x 2-1/2 in. course drywall screw through the center grommet. Furring channels are friction fitted into clips.

**CLARKDIETRICH BUILDING SYSTEMS** — Type ClarkDietrich Sound Clips

7. **Gypsum Board\*** — Nom 5/8 in. thick, 48 in. wide gypsum board installed with long dimension perpendicular to resilient channels. Gypsum board secured with 1-1/8 in. long Type S bugle head steel screws spaced 8 in. OC and located a min of 1/2 in. from side joints and 3 in. from the end joints. End joints secured to both resilient channels as shown in end joint details.

When **Steel Framing Members** (Item 6A) are used, nom 5/8 in. thick, 4 ft wide gypsum board, installed as described in Item 7. Adjacent butt joints staggered minimum 48 in. OC.

When **Steel Framing Members** (Item 6B) are used, nom 5/8 in. thick, 4 ft wide gypsum board, installed as described in Item 7. Butt joints staggered minimum 24 in. OC.

When **Steel Framing Members** (Item 6D, 6G) are used, gypsum panels installed with long dimensions perpendicular to furring channels. Panels attached to the furring channels using 1 in. long Type S bugle-head steel screws spaced 8 in. OC along butted end joints and in the field of the panel. Butted end joints shall be staggered min. 2 ft within the assembly, and occur midway between the continuous furring channels. Each end of each gypsum panel shall be supported by a single length of furring channel equal to the width of the gypsum panel plus 6 in. on each end. The two support furring channels shall be spaced approximately 3-1/2 in. OC, and be attached with one clip at each end of the channel.

**NATIONAL GYPSUM CO** — Types eXP-C, FSW-G, FSW-C, FSK-G, FSK-C.

7A. **Gypsum Board\*** — For use with items 5A or 5B and 6E-Nom 5/8 in. thick, 48 in. wide gypsum panels. Installed with long dimension perpendicular to resilient channels. Gypsum panels secured with 1 in. long Type S bugle head steel screws spaced 8 in. OC and located a min of 1/2 in. from side joints and 3 in. from the end joints, and butted end joints shall be staggered min. 16 in. within the

assembly and occur midway between the continuous furring channels. End joints secured to both resilient channels as shown in end joint detail. Not to be used with ceiling damper items 4-4AA.

**NATIONAL GYPSUM CO** — Type FSLX

8. **Finishing System** — (Not Shown) — Vinyl, dry or premixed joint compound, applied in two coats to joints and screw-heads. Nom 2 in. wide paper tape embedded in first layer of compound over all joints. As an alternate, nom 3/32 in. thick veneer plaster may be applied to the entire surface of gypsum board.

9. **Grille** — Steel grille, installed in accordance with the installation instructions provided with the ceiling damper.

10. **Discrete Products Installed in Air-handling Spaces\*** — Automatic Balancing Valve/Damper — (Not Shown - Optional) — For use with item 4M, Ruskin Company's Model CFD7T damper (CABS). Ceiling damper to be provided with plenum box per damper manufacturer's instructions with side outlet only. Entire assembly to be installed into any UL Class 0 or Class 1 flexible air duct in accordance with the instructions provided by the automatic balancing valve/damper manufacturer.

**METAL INDUSTRIES INC** — Model ABV-4, ABV-5, ABV-6

**\* Indicates such products shall bear the UL or cUL Certification Mark for jurisdictions employing the UL or cUL Certification (such as Canada), respectively.**

Last Updated on 2023-04-04