

Design No. **L518**  
February 14, 2022

**Unrestrained Assembly Rating — 1 Hr.**  
**Finish Rating — 54 Min.**

**This design was evaluated using a load design method other than the Limit States Design Method (e.g., Working Stress Design Method). For jurisdictions employing the Limit States Design Method, such as Canada, a load restriction factor shall be used — See Guide [BXUV](#) or [BXUV7](#)**

**\* Indicates such products shall bear the UL or cUL Certification Mark for jurisdictions employing the UL or cUL Certification (such as Canada), respectively.**

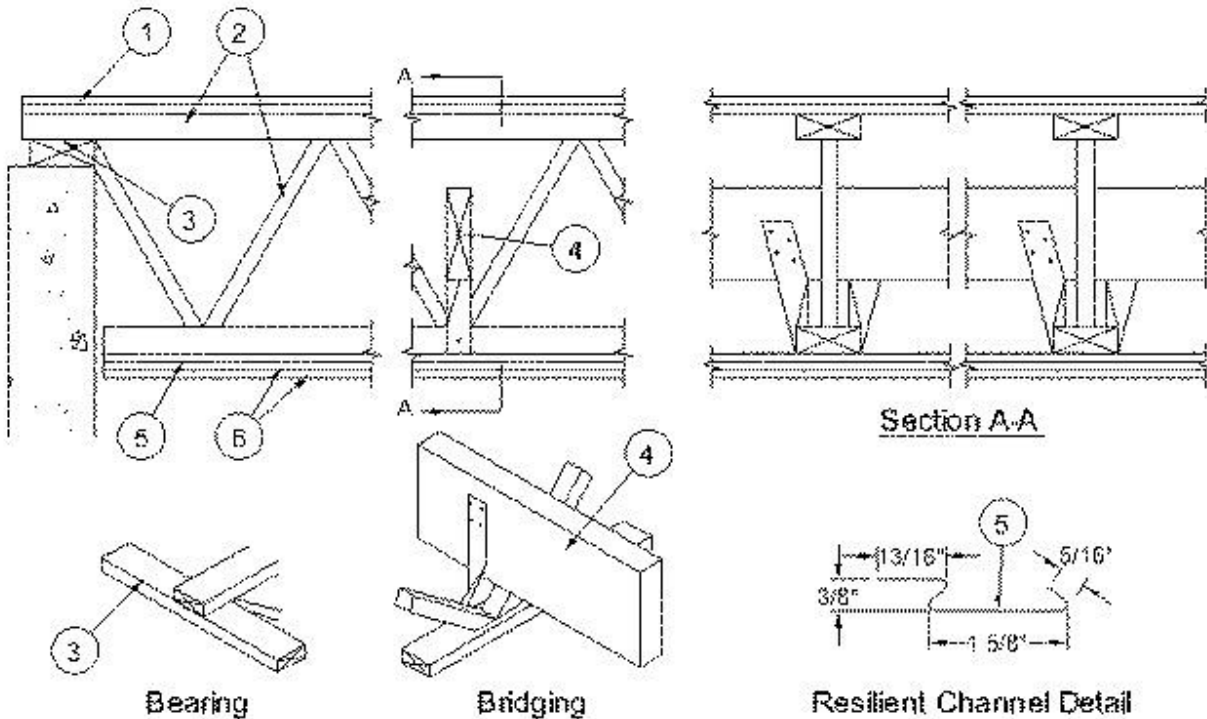

1. **Flooring Systems** — The flooring system shall consist of one of the following:

**System No. 1**

**Subflooring** — Min 19/32 in. thick wood structural panels, min grade "C-D" or "Sheathing". Face grain of plywood or strength axis of panels to be perpendicular to joists with joints staggered.

**Finish Flooring** — Min 19/32 in. thick wood structural panels, min grade "Underlayment" or "Single-Floor". Face grain of plywood or strength axis of panels to be perpendicular to joists with joints staggered.

**System No. 2**

**Subflooring** — Min 19/32 in. thick wood structural panels, min grade "C-D" or "Sheathing". Face grain of plywood or strength axis of panels to be perpendicular to joists with joints staggered.

**Vapor Barrier - (Optional)** — Nom 0.010 in. thick commercial asphalt saturated felt.

**Finish Flooring - Floor Topping Mixture\*** — Min 3/4 in. thickness of floor topping mixture having a minimum compressive strength of 1800 psi. Refer to manufacturer's instructions accompanying the material for specific mix design.

**UNITED STATES GYPSUM CO** — Types LRK, HSLRK, CSD

**USG MEXICO S A DE C V** — Types LRK, HSLRK, CSD

**Floor Mat Materials\*** — (Optional) - Floor mat material loose laid over the subfloor. Refer to manufacturer's instructions regarding the minimum thickness of floor topping over each floor mat material.

**UNITED STATES GYPSUM CO** — Types SAM, LEVELROCK® Brand Sound Reduction Board, LEVELROCK® Brand Floor Underlayment SRM-25

**Alternate Floor Mat Materials\* - (Optional)** — Nom 3/8 in. thick floor mat material loose laid over the subfloor. Floor topping thickness shall be as specified under **Floor Topping Mixture**.

**GRASSWORX L L C** — Type SC50

**Alternate Floor Mat Material\*** — (Optional) - Floor mat material nominal 3/8 in. thick loose laid over the subfloor. Floor topping shall be a min 3/4 in. thick.

### **System No. 3**

**Subflooring** — Min 19/32 in. thick wood structural panels, min grade "C-D" or "Sheathing". Face grain of plywood or strength axis of panels to be perpendicular to joists with joints staggered.

**Floor Mat Materials\* — (Optional)** — Floor mat material nom 5/64 in. (2 mm) thick adhered to subfloor with Hacker Floor Primer. Primer to be applied to the surface of the mat prior to the placement of a min 1 in. of floor-topping mixture.

**HACKER INDUSTRIES INC** — Type Hacker Sound-Mat.

**Alternate Floor Mat Materials - (Optional)** — Floor mat material nom 1/4 in. (6 mm) thick adhered to concrete slab with Hacker Floor Primer. Primer to be applied to the surface of the mat prior to the placement of a min 1-1/4 in. (32 mm) of floor-topping mixture.

**HACKER INDUSTRIES INC** — Type Hacker Sound-Mat II.

**Alternate Floor Mat Materials - (Optional)** — Floor mat material nom 1/8 in. (3 mm) thick loose laid over the concrete slab. Floor topping thickness shall be a min of 3/4 in. (19 mm)

**HACKER INDUSTRIES INC** — FIRM-FILL SCM 125

**Alternate Floor Mat Materials - (Optional)** — Floor mat material nom 1/4 in. (6 mm) thick loose laid over the concrete slab. Floor topping thickness shall be a min of 1 in. (25 mm)

**HACKER INDUSTRIES INC** — Type FIRM-FILL SCM 250, Quiet Qurl 55/025

**Alternate Floor Mat Materials - (Optional)** — Floor mat material nom 3/8 in. (10 mm) thick loose laid over the concrete slab. Floor topping thickness shall be a min of 1-1/4 in. (32 mm)

**HACKER INDUSTRIES INC** — FIRM-FILL SCM 400, Quiet Qurl 60/040

**Alternate Floor Mat Materials - (Optional)** — Floor mat material nom 3/4 in. (19 mm) thick loose laid over the concrete slab. Floor topping thickness shall be a min of 1-1/2 in. (38 mm)

**HACKER INDUSTRIES INC** — Type FIRM-FILL SCM 750, Quiet Qurl 65/075

**Metal Lath (Optional)** — For use with 3/8 in. (10 mm) floor mat materials, 3/8 in. expanded steel diamond mesh, 3.4 lbs/sq yd placed over the floor mat material. Hacker Floor Primer to be applied prior to the placement of the metal lath. When metal lath is used, floor topping thickness a nom 1-1/4 in. over the floor mat.

**Finish Flooring - Floor Topping Mixture\*** — Min 3/4 in. thickness of floor topping mixture having a min compressive strength of 1100 psi. Mixture shall consist of 6.8 gal of water to 80 lbs of floor topping mixture to 1.9 cu ft of sand.

**HACKER INDUSTRIES INC** — Firm-Fill Gypsum Concrete, Firm-Fill 2010, Firm-Fill 4010, Firm-Fill High Strength and Gyp-Span Radiant

#### **System No. 4**

**Subflooring** — Min 19/32 in. thick wood structural panels, min grade "C-D" or "Sheathing". Face grain of plywood or strength axis of panels to be perpendicular to joists with joints staggered.

**Vapor Barrier - (Optional)** — Nom 0.030 in. thick commercial asphalt saturated felt.

**Finish Flooring - Floor Topping Mixture\*** — Min 1-1/2 in. thickness of floor topping mixture having a min compressive strength of 1000 psi and a cast density of 100 plus or minus 5 pcf. Foam

concentrate mixed 40:1 by volume with water and expanded at 100 psi through nozzle. Mixture shall consist of 1.4 cu feet of preformed foam concentrate to 94 lbs Type I Portland cement, 300 lbs of sand with 5-1/2 gal of water.

**ELASTIZELL CORP OF AMERICA** — Type FF

#### **System No. 5**

Deleted.

#### **System No. 6**

**Subflooring** — Min 19/32 in. thick wood structural panels, min grade "C-D" or "Sheathing". Face grain of plywood or strength axis of panels to be perpendicular to joists with joints staggered.

**Vapor Barrier - (Optional)** — Nom 0.030 in. thick commercial asphalt saturated felt.

**Finish Flooring - Floor Topping Mixture\*** — Min 1 in. thickness of floor topping mixture having a min compressive strength of 1000 psi. Mixture shall consist of 5 to 8 gal of water mixed with 80 lbs of floor topping mixture and 2.1 cu ft of sand.

**ULTRA QUIET FLOORS** — Types UQF-A, UQF-Super Blend, UQF-Plus 200

#### **System No. 7**

**Subflooring** — Min 19/32 in. thick wood structural panels, min grade "C-D" or "Sheathing". Face grain of plywood or strength axis of panels to be perpendicular to joists with joints staggered.

**Vapor Barrier - (Optional)** — Nom 0.030 in. thick commercial asphalt saturated felt.

**Finish Flooring - Floor Topping Mixture\*** — Min 3/4 in. thickness of floor topping mixture having a minimum compressive strength of 1500 psi. Refer to manufacturer's instructions accompanying the material for specific mix design.

**MAXXON CORP** — Type Maxxon Standard and Maxxon High Strength

**Floor Mat Materials\* - (Optional)** — Floor mat material loose laid over the subfloor. Refer to manufacturer's instructions regarding the minimum thickness of floor topping over each floor mat material.

**MAXXON CORP** — Type Encapsulated Sound Mat.

**Floor Mat Reinforcement** — (Optional) Refer to manufacturer's instructions regarding minimum thickness of floor topping for use with floor mat reinforcement.

**Metal Lath** — (Optional) 3/8 in. expanded galvanized steel diamond mesh, 3.4 lbs/sq yd loose laid over the floor mat material.

**Fiber Glass Reinforcement** - (Optional, Not Shown) - 0.015 in. thick PVC coated non-woven fiberglass mesh, 0.368 lbs/sq yd loose laid over the floor mat material.

#### **System No. 8**

**Subflooring** — Min 15/32 in. thick wood structural panels, min grade "C-D" or "Sheathing". Face grain of plywood or strength axis of panels to be perpendicular to joists with joints staggered.

**Vapor Barrier** — (Optional) Nom 0.030 in. thick commercial asphalt saturated felt.

**Finish Flooring — Floor Topping Mixture\*** — Min 3/4 in. thickness of floor topping mixture having a minimum compressive strength of 1500 psi. Refer to manufacturer's instructions accompanying the material for specific mix design.

**FORMULATED MATERIALS LLC** — Types FR-25, FR-30, and SiteMix

**Alternate Floor Mat Material\*** — (Optional) Floor mat material nominal 2 - 9.5 mm thick loose laid over the subfloor. Floor topping thickness shall be a minimum of 3/4 in.

**FORMULATED MATERIALS LLC** — Types M1, M2, M3, Elite, Duo, R1, and R2

#### **System No. 9**

**Sub-flooring** — Min 1 by 6 in. T & G lumber fastened diagonally to joists; or min 15/32 in. thick plywood or min 7/16 in. thick oriented strand board (OSB) wood structural panels, min grade "C-D" or "Sheathing". Face grain of plywood or strength axis of panel to be perpendicular to joists with joints staggered.

**Finish Floor - Mineral and Fiber Board\*** — Min 1/2 in. thick, supplied in sizes ranging from 3 ft by 4 ft to 8 ft by 12 ft. All joints to be staggered a min of 12 in. with adjacent sub-floor joints.

**HOMASOTE CO** — Type 440-32 Mineral and Fiber Board

#### **System No. 10**

**Subflooring** — Min 19/32 in. thick wood structural panels, min grade "C-D" or "Sheathing". Face grain of plywood or strength axis of panels to be perpendicular to joists with joints staggered.

**Vapor Barrier- (Optional)** — Nom 0.030 in. thick commercial asphalt saturated felt.

**Finish Flooring - Floor Topping Mixture\*** — Min 1-1/2 in. thickness of floor topping mixture having a min compressive strength of 1000 psi and a cast density of 100 plus or minus 5 pcf. Foam concentrate mixed 40:1 by volume with water and expanded at 100 psi through nozzle. Mixture shall consist of 1.2 cu feet of preformed foam concentrate to 94 lbs Type I Portland cement, 300 lbs of sand with 5-1/2 gal of water.

**AERIX INDUSTRIES** — Floor Topping Mixture

### **System No. 11**

**Subflooring** — Min 15/32 in. thick wood structural panels, min grade "C-D" or "Sheathing". Face grain of plywood or strength axis of panels to be perpendicular to joists with joints staggered.

**Vapor Barrier - (Optional)** — Nom 0.030 in. thick commercial asphalt saturated felt.

**Finish Flooring - Floor Topping Mixture\*** — Min 3/4 or 1 in. thickness of floor topping mixture for 19/32 or 15/32 in. thick wood structural panels respectively, having a min compressive strength of 1000 psi. Refer to manufacturer's instructions accompanying the material for specific mix design.

**ARCOSA SPECIALTY MATERIALS** — AccuCrete® Types NexGen, Green, Prime and PrePour, AccuRadiant®, AccuLevel® Types G40, G50 and SD30

**Alternate Floor Mat Material\*** - (Optional) - Floor mat material nominal 2 - 9.5 mm thick loose laid over the subfloor. Floor topping shall be a min of 3/4 in. or 1 in. thickness of floor topping mixture for 19/32 or 15/32 in. thick wood structural panels respectively.

**ARCOSA SPECIALTY MATERIALS** — AccuQuiet® Types D13, D-18, D25, DX38, EM.125, EM.125S, EM.250, EM.250S, EM.375, EM.375S, EM.750, and EM.750S.

### **System No. 12**

**Subflooring** — 15/32 or 19/32 in. thick wood structural panels, min. grade "C-D" or "Sheathing". Face grain of plywood or strength axis of panels to be perpendicular to joists with joints staggered.

**Vapor Barrier — (Optional)** — Nom 0.030 in. thick commercial asphalt saturated felt.

**Finish Flooring — Floor Topping Mixture\*** — Min 3/4 or 1 in. thickness of floor topping mixture for 19/32 or 15/32 in. thick wood structural panels respectively, having a min compressive strength of 2100 psi. Refer to manufacturer's instructions accompanying the material for specific mix design. Refer to the manufacturer's instructions accompanying the material and/or contact the manufacturer's technical support for specific mix design and minimum thickness recommended for use with eligible floor mat(s).

### **System No. 13**

**Subflooring** — Min 15/32 in. thick wood structural panels, min grade "C-D" or "Sheathing". Face grain of plywood or strength axis of panels to be perpendicular to the joists with joints staggered.

**Vapor Barrier** — (Optional) - Commercial asphalt saturated felt, 0.030 in. thick.

**Vapor Barrier** — (Optional) - Nom 0.010 in. thick commercial rosin-sized building paper.

**Finish Flooring\*** — Min 3/4 in. thickness of any Floor Topping Mixture bearing the UL Classification Marking as to Fire Resistance. See Floor- and Roof-Topping Mixtures (CCOX) category for names of Classified Companies. Refer to the manufacturer's instructions accompanying the material and/or

contact the manufacturer's technical support for specific mix design and minimum thickness recommended for use with eligible floor mat(s).

**Floor Mat Materials\*** — (Optional) - Nom. 1/4 in. thick loose laid over the subfloor. Floor topping thickness shall be a minimum of 3/4 in.

**KEENE BUILDING PRODUCTS CO INC** — Type Quiet Qurl 55/025 and Quiet Qurl 55/025 N

**Alternate Floor Mat Materials\*** — (Optional) - Floor mat material Nom. 3/8 in. thick loose laid over the subfloor. Floor topping thickness shall be a minimum of 1 in.

**KEENE BUILDING PRODUCTS CO INC** — Type Quiet Qurl 60/040 and Quiet Qurl 60/040 N

**Alternate Floor Mat Materials\*** — (Optional) - Floor mat material Nom. 3/4 in. thick loose laid over the subfloor. Floor topping thickness shall be a minimum of 1-1/2 in.

**KEENE BUILDING PRODUCTS CO INC** — Type Quiet Qurl 65/075, Quiet Qurl 65/075 N

**Alternate Floor Mat Materials\*** — (Optional) - Floor mat material Nom. 1/8 in. thick loose laid over the subfloor. Floor topping thickness shall be a minimum of 3/4 in.

**KEENE BUILDING PRODUCTS CO INC** — Type Quiet Qurl 52/013 and Quiet Qurl 52/013 N

**Alternate Floor Mat Materials\*** — (Optional) - Floor mat material Nom. 1/4 in. entangled net core with a compressible fabric attached to the bottom loose laid over the subfloor. Floor topping thickness shall be a minimum of 1 in.

**KEENE BUILDING PRODUCTS CO INC** — Quiet Qurl 55/025 MT and Quiet Qurl 55/025 N MT

### **System No. 14**

**Subflooring** — Min 23/32 in. thick T&G wood structural panels, min grade "Underlayment" or "Single-Floor". Face grain of plywood or strength axis of panels to be perpendicular to the trusses with end joints staggered 4 ft. Panels secured to trusses with construction adhesive and No. 6d ringed shank nails spaced 12 in. OC along each truss. Staples having equal or greater withdrawal and lateral resistance strength may be substituted for the 6d nails.

**Gypsum Board\*** — One layer of nom 5/8 in. thick, 4 ft wide gypsum board, installed with long dimension perpendicular to joists. Gypsum board secured with 1 in. long No. 6 Type W bugle head steel screws spaced 12 in. OC and located a min of 1-1/2 in. from side and end joints. The joints of the gypsum board are to be staggered a minimum of 12 inches from the joints of the subfloor.

**GEORGIA-PACIFIC GYPSUM L L C** — Type DS

**Floor Mat Materials\*** — (As an alternate to the single layer gypsum board) - Floor mat material loose laid over the subfloor.

**MAXXON CORP** — Type Encapsulated Sound Mat.

**Gypsum Board\*** — (For use when floor mat is used) Two layers of nom 5/8 in. thick, 4 ft wide gypsum board, installed with long dimension perpendicular to joists on top of the floor mat material. Gypsum board secured to each other with 1 in. long No. 6 Type G bugle head steel screws spaced 12 in. OC and located a min of 1-1/2 in. from side and end joints. The joints of the gypsum board are to be staggered a minimum of 12 inches in between layers and from the joints of the subfloor.

**GEORGIA-PACIFIC GYPSUM L L C** — Type DS

### **System No. 15**

**Subflooring** — Min 19/32 in. thick wood structural panels, min grade "C-D" or "Sheathing". Face grain of plywood or strength axis of panels to be perpendicular to joists with joints staggered.

**Vapor Barrier** — (Optional) — Nom 0.030 in. thick commercial asphalt saturated felt.

**Finish Flooring - Floor Topping Mixture\*** — Min 3/4 or 1 in. thickness of floor topping mixture for 19/32 or 15/32 in. thick wood structural panels respectively, having a min compressive strength of 1000 psi. Refer to manufacturer's instructions accompanying the material for specific mix design.

**DEPENDABLE LLC** — GSL M3.4, GSL K2.6, GSL-CSD and GSL RH

**Floor Mat Materials\*** — (Optional) - Nom. 1/4 in. thick loose laid over the subfloor. Floor topping thickness shall be a minimum of 3/4 in.

**KEENE BUILDING PRODUCTS CO INC** — Type Quiet Qurl 55/025 and Quiet Qurl 55/025 N

**Alternate Floor Mat Materials\*** — (Optional) - Floor mat material Nom. 3/8 in. thick loose laid over the subfloor. Floor topping thickness shall be a minimum of 1 in.

**KEENE BUILDING PRODUCTS CO INC** — Type Quiet Qurl 60/040 and Quiet Qurl 60/040 N

**Alternate Floor Mat Materials\*** — (Optional) - Floor mat material Nom. 3/4 in. thick loose laid over the subfloor. Floor topping thickness shall be a minimum of 1-1/2 in.

**KEENE BUILDING PRODUCTS CO INC** — Type Quiet Qurl 65/075, Quiet Qurl 65/075 N



**Alternate Floor Mat Materials\*** — (Optional) - Floor mat material Nom. 1/8 in. thick loose laid over the subfloor. Floor topping thickness shall be a minimum of 3/4 in.

**KEENE BUILDING PRODUCTS CO INC** — Type Quiet Qurl 52/013 and Quiet Qurl 52/013 N

**Alternate Floor Mat Materials\*** — (Optional) - Floor mat material Nom. 1/4 in. entangled net core with a compressible fabric attached to the bottom loose laid over the subfloor. Floor topping thickness shall be a minimum of 1 in.

**KEENE BUILDING PRODUCTS CO INC** — Quiet Qurl 55/025 MT and Quiet Qurl 55/025 N MT

### **System No. 16**

**Subflooring** — Min 19/32 in. thick wood structural panels, min grade "C-D" or "Sheathing". Face grain of plywood or strength axis of panels to be perpendicular to the joists with joints staggered.

**Vapor Barrier** — (Optional) - Commercial asphalt saturated felt, 0.030 in. thick.

**Vapor Barrier** — (Optional) - Nom 0.010 in. thick commercial rosin-sized building paper.

**Finish Flooring\*** — Min 3/4 in. thickness of any Floor Topping Mixture bearing the UL Classification Marking as to Fire Resistance. See Floor- and Roof-Topping Mixtures (CCOX) category for names of Classified Companies.

**Floor Mat Materials\*** — (Optional) - Nom 3/32 in. thick loose laid over the subfloor. Floor topping thickness shall be a minimum of 3/4 in.

**PLITEQ INC** — Type GenieMat RST02

**Floor Mat Materials\*** — (Optional) - Nom 3/16 in. thick loose laid over the subfloor. Floor topping thickness shall be a minimum of 3/4 in.

**PLITEQ INC** — Type GenieMat FF03NP

**Floor Mat Materials\*** — (Optional) - Nom 1/4 in. thick loose laid over the subfloor. Floor topping thickness shall be a minimum of 3/4 in.

**PLITEQ INC** — Type GenieMat FF06

**Floor Mat Materials\*** — (Optional) - Nom 3/8 in. thick loose laid over the subfloor. Floor topping thickness shall be a minimum of 1 in.

**PLITEQ INC** — Type GenieMat FF10

**Floor Mat Materials\*** — (Optional) - Nom 3/4 in. thick loose laid over the subfloor. Floor topping thickness shall be a minimum of 1-1/2 in.

**PLITEQ INC** — Type GenieMat FF17

**Floor Mat Materials\*** — (Optional) - Nom 1 in. thick loose laid over the subfloor. Floor topping thickness shall be a minimum of 1-1/2 in.

**PLITEQ INC** — Type GenieMat FF25

### **System No. 17**

**Subflooring** — Min 19/32 in. thick wood structural panels, min grade "C-D" or "Sheathing." Face grain of plywood or strength axis of panel to be perpendicular to joists with joints staggered.

**Finish Flooring\* — Floor Topping Materials** — Min 3/4 in. to 1-1/2 in. thickness of any Floor Topping Mixture bearing the UL Classification Marking as to Fire Resistance with a minimum compressive strength of 1500 psi.

See **Floor- and Roof-Topping Mixtures** (CCOX) category for names of Classified Companies.

**Floor Mat Materials\*** — (Optional) — Floor mat material nom 1/8 in. to 3/4 in. thick. Loose laid over the subfloor. When used, Acousti-flor CSM (crack suppression mat) is loose laid over the floor mat material. Floor topping material thickness is dependent on thickness of floor mat used.

**WALFLOR INDUSTRIES INC** — Type Acousti-flor, Acousti-flor CSM. Floor topping thickness depends on products used as follows:

Acousti-flor (1/8 in. thick) - Floor topping thickness shall be a minimum of 3/4 in.

Acousti-flor (1/4 in. thick) - Floor topping thickness shall be a minimum of 1 in.

Acousti-flor (3/8 in. thick) - Floor topping thickness shall be a minimum of 1 in.

Acousti-flor (3/4 in. thick) - Floor topping thickness shall be a minimum of 1-1/2 in.

**Metal Lath** — (Optional) — Expanded steel diamond mesh, 2.5 lb / sq yd loose laid over floor mat material.

**Fiberglass Mesh Reinforcement** — (Optional) — Coated non-woven glass fiber mesh grid loose laid over floor mat material.

### **System No. 18**

**Subflooring** — Min 19/32 in. thick wood structural panels, min grade "C-D" or "Sheathing". Face grain of plywood or strength axis of panels to be perpendicular to joists with joints staggered.

**Finish Flooring - Floor Topping Mixture\*** — Min 1 in. thickness of floor topping mixture having a min compressive strength of 4500 psi. Refer to manufacturer's instructions accompanying the material for specific mix design.

**SIKA DEUTSCHLAND GMBH** — Type SCHONOX AP Rapid Plus

### **System No. 19**

**Subflooring** — Min 19/32 in. thick wood structural panels, min grade "C-D" or "Sheathing". Face grain of plywood or strength axis of panels to be perpendicular to joists with joints staggered.

**Vapor Barrier** — (Optional) - Commercial asphalt saturated felt, 0.030 in. thick.

**Vapor Barrier** — (Optional) - Nom 0.010 in. thick commercial rosin-sized building paper.

**Finish Flooring - Floor Topping Mixture\*** — Min 3/4 in. thickness of any Floor Topping Mixture bearing the UL Classification Marking as to Fire Resistance. See Floor- and Roof-Topping Mixtures (CCOX) category for names of Classified Companies.

**Floor Mat Materials\*** — (Optional, Not Shown) - Floor mat material loose laid over the subfloor. Refer to manufacturer's instructions regarding the minimum thickness of floor topping over each floor mat material.

**LOW & BONAR INC** — EnkaSonic® by Colbond a member of the Low & Bonar group Types 125, 250, 250 Plus, 400, 400 Plus, 750, and 750 Plus.

**Floor Mat Reinforcement** — (Optional) - Refer to manufacturer's instructions regarding minimum thickness of floor topping for use with floor mat reinforcement.

**Metal Lath** — (Optional) — Expanded steel diamond mesh, 2.5 lb / sq yd loose laid over floor mat material.

**Fiberglass Mesh Reinforcement** — (Optional) — Coated non-woven glass fiber mesh grid loose laid over floor mat material.

2. **Structural Wood Members** — Min 9-1/2 in. deep "I" shaped wood joists spaced at a max of 24 in. OC. Joists shall conform to ICC-ES ESR-1153 Report. Joist top and bottom chords minimum 1-3/8 in. deep by 2.3 in. wide and constructed of either Microllam laminated veneer lumber (LVL) or TimberStrand laminated strand lumber (LSL). Webs constructed of minimum 3/8 in. thick Performance Plus OSB, PS2, Exposure 1. Installation shall be in accordance with manufacturers published literature.

3. **Bearing** — Factory-installed bearing clips, formed of min 0.084 in. (13 gauge) galv steel shall be used to attach the joists to the bearing plate.

4. **Bridging** — When the wood and steel trusses described in Item 2 are used, nom 2 by 6 in. lumber attached to bottom chord of each joist with two, min 0.045 in. thick (18 gauge) galv bridging clips. The bridging clips are pin-connected to the bottom chord of the joists and nailed to the bridging lumber with four 3 in. long 10d nails.

5. **Resilient Channels** — Nom 1/2 in. deep, 2-1/2 in. wide, formed of min 0.021 in. thick (25 gauge) galv steel. Installed perpendicular to the I-joists and attached to the bottom flange of each joist with 1-5/8 in. long self-drilling, self-tapping No. 6 Type S bugle head steel screw. Continuous rows of channels spaced 16 in. OC. Splices of continuous channels to be centered on the joists and overlap a min of 2-1/4 in. Additional 60 in. long pieces installed midway between the adjacent continuous channels, at locations of the end joints in the base (upper) layer of gypsum board. Ends of the 60 in. long pieces of resilient channels to extend 6 in. beyond the centerline of the I-joists.

5A. **Steel Framing Members\*** — (Not Shown) As an alternate to Item 5, furring channels and **Steel Framing Members\*** as described below. Allowable for use with **Structural Wood Members\*** (Item 2) only when spacing is 24 in. OC or less

a. **Furring Channels** — Formed of No. 25 MSG galv steel, 2-9/16 in. or 2-23/32 in. wide by 7/8 in. deep, spaced 24 in. OC perpendicular to structural wood members. Channels secured to structural wood members as described in Item b. Ends of adjoining channels overlapped 6 in. and tied together with double strand of No. 18 SWG galv steel wire near each end of overlap.

b. **Steel Framing Members\*** — Used to attach furring channels (Item a) to Structural Wood Members\* (Items 2 or 2A). Clips spaced 48 in. OC., and secured to alternating structural wood members with No. 8 x 2-1/2 in. coarse drywall screw through the center grommet. Type RSIC-Si-X secured with No. 10 x 3-1/2 in. screws. Furring channels are friction fitted into clips. RSIC-1 and RSIC-Si-X clip for use with 2-9/16 in. wide furring channels. RSIC-1 (2.75) clip for use with 2-23/32 in. wide furring channels. Adjoining channels are overlapped as described in Item a. As an alternate, ends of adjoining channels may be overlapped 6 in. and secured together with two self-tapping No. 6 framing screws, min 7/16 in. long at the midpoint of the overlap, with one screw on each flange of the channel. Additional clips required to hold furring channel that supports the gypsum board butt joints, as described in Item 6.

**PAC INTERNATIONAL L L C** — Types RSIC-1, RSIC-Si-X, RSIC-1 (2.75).

5B. **Steel Framing Members\*** — (Not Shown) As an alternate to Item 5 and 5A, furring channels and **Steel Framing Members\*** as described below. Allowable for use with **Structural Wood Members\*** (Item 2) only when spacing is 24 in. OC or less.

a. **Furring Channels** — Formed of No. 25 MSG galv steel, 2-3/8 in. wide by 7/8 in. deep, spaced 24 in. OC perpendicular to structural wood members. Channels secured to structural wood members as described in Item b. Ends of adjoining channels overlapped 6 in. and tied together with double strand of No. 18 SWG galv steel wire near each end of overlap.

b. **Steel Framing Members\*** — Used to attach furring channels (Item a) to **Structural Wood Members\*** (Items 2 or 2A). Clips spaced 48 in. OC., and secured to alternating structural wood members with No. 8 x 2-1/2 in. coarse drywall screw through the center hole. Furring channels are friction fitted into clips. Additional clips required to hold furring channel that supports the gypsum board butt joints, as described in Item 6.

**PLITEQ INC** — Type Genie Clip

5C. **Alternate Steel Framing Members\*** — (Not Shown) - As an alternate to Items 5, 5A, and 5B, furring channels and Steel Framing Members as described below.

a. **Furring Channels** — Formed of No. 25 MSG galv steel, 2-5/8 in. wide by 7/8 in. deep, spaced 24 in. OC, perpendicular to joists. Channels secured to joists as described in Item b.

b. **Steel Framing Members\*** — Used to attach furring channels (Item a) to the **Structural Wood Members\*** (Item 2). Clips spaced at 48" OC and secured to the bottom of the joists with one 2 in. Coarse Drywall Screw with 1 in. diam washer through the center hole. Furring channels are then friction fitted into clips. Ends of channels are overlapped 6" and tied together with double strand of No. 18 AWG galvanized steel wire. Additional clips are required to hold the Gypsum Butt joints as described in Item 6.

**STUDCO BUILDING SYSTEMS** — RESILMOUNT Sound Isolation Clips - Type A237R

**5D. Steel Framing Members\*** — (Not Shown) As an alternate to Item 5, furring channels and **Steel Framing Members\*** as described below. Allowable for use with **Structural Wood Members\*** (Item 2) only when spacing is 24 in. OC or less

a. **Furring Channels** — Formed of No. 25 MSG galv steel, 2-23/32 in. wide by 7/8 in. deep, spaced 24 in. OC perpendicular to structural wood members. Channels secured to structural wood members as described in Item b. Ends of adjoining channels overlapped 6 in. and tied together with double strand of No. 18 SWG galv steel wire near each end of overlap.

b. **Steel Framing Members\*** — Used to attach furring channels (Item a) to Structural Wood Members\* (Items 2 or 2A). Clips spaced 48 in. OC., and secured to alternating structural wood members with No. 8 x 2-1/2 in. coarse drywall screw through the center grommet. Furring channels are friction fitted into clips. Adjoining channels are overlapped as described in Item a. As an alternate, ends of adjoining channels may be overlapped 6 in. and secured together with two self-tapping No. 6 framing screws, min 7/16 in. long at the midpoint of the overlap, with one screw on each flange of the channel. Additional clips required to hold furring channel that supports the gypsum board butt joints, as described in Item 6.

**CLARKDIETRICH BUILDING SYSTEMS** — Type ClarkDietrich Sound Clip

**5E. Steel Framing Members\*** — (Optional, Not Shown) — As an alternate to Item 5.

a. **Furring Channels** — Formed of No. 25 MSG galv steel, nominal 2-1/2 in. wide by 7/8 in. deep, spaced 24 in. OC, perpendicular to the joists. Channels secured to Cold Rolled Channels at every intersection with a 3/4 in. TEK screw through each furring channel leg. Ends of adjoining channels overlapped 12 in. and fastened together with two double strand No. 18 SWG galv steel wire ties, one at each end of overlap, or with two 3/4 in. TEK screws in each leg of the overlap section. Two furring channels positioned 3 in. OC, 1-1/2 in. on each side of gypsum board (Item 6) end joints, each extending a min of 6 in. beyond both side edges of the board.

b. **Cold Rolled Channels** — 1-1/2 in. by 1/2 in., formed from No. 16 ga. galv steel, positioned vertically and parallel to joists, friction-fitted into the channel caddy on the Steel Framing Members (Item 5Ec) and secured with two 3/4 in. TEK screws. Adjoining lengths of cold rolled channels lapped min. 12 in. and secured along bottom legs with four 3/4 in. TEK screws and wire-tied together with two double strand 18 SWG galv steel wire ties, one at each end of overlap.

c. **Steel Framing Members\*** — Spaced 48 in. OC. max along joist, and secured to the joist on alternating joists with two, #10 x 1-1/2 in. screws through mounting holes on the hanger bracket.

**PAC INTERNATIONAL L L C** — Type RSIC-SI-CRC EZ Clip

**5F. Steel Framing Members\*** — (Optional, Not Shown) — As an alternate to Item 5.

a. **Furring Channels** — Formed of No. 25 MSG galv steel, nominal 2-1/2 in. wide by 7/8 in. deep, spaced 24 in. OC perpendicular to joists and friction fit into Steel Framing Members (Item 5Fb). Ends of adjoining channels overlapped 6 in. and tied together with double strand of No. 18 SWG galv steel wire near each end of overlap or with two TEK screws along each leg of the 6 in. overlap. Two furring channels positioned 6 in. OC, 3 in. on each side of gypsum board (Item 6) end joints. Butt joint channels held in place by strong back channels placed upside down, on top of, and running perpendicular to primary furring channels, extending 6 in. longer than length of gypsum side joint. Strong back channels spaced maximum 48 in. OC. Strong back channels secured to every intersection of primary furring channels with four 7/16 in. pan head screws, two along each of the legs at intersections. Butt joint channels run perpendicular to strong back channels and shall be

minimum 6 in. longer than length of joint, secured to strong back channels with 7/16 in. pan head screws, two along each of the legs at intersection with strong back channels.

b. **Steel Framing Members\*** — Used to attach furring channels (Item 5Fa) to joists. Clips spaced 48 in. OC and secured along joist webs at each furring channel intersection with min. 3/4 in. long self-drilling #10 x 1-1/2 in. screws through each of the provided hole locations. Furring channels are friction fitted into clips.

**PAC INTERNATIONAL L L C** — Type RSIC-S1-1 Ultra

5G. **Steel Framing Members\*** — (Optional - Not Shown) — Used to attach resilient channels (Item 5) to joists (Item 2). Clips spaced 48 in. OC and secured to joists with one No. 8 x 2-1/2 in. coarse drywall screw through center grommet hole. Channels secured to clips with one #10 x 1/2 in. pan-head self-drilling screw. Ends of adjoining channels overlapped 6 in. and secured together with two #8 15 x 1/2 in. Philips Modified screws spaced 2-1/2 in. from the center of the overlap. Gypsum board butt joints require additional resilient channels spaced 1-1/2 in. from the butt joint on either side. One edge of the extra channels will extend to an adjacent joist where it is secured with a clip.

**KEENE BUILDING PRODUCTS CO INC** — Type RC+ Assurance Clip

5H. **Steel Framing Members\*** — (Optional, Not Shown) — Used as an alternate method to attach resilient channels to structural members. A resilient sound isolation accessory shall be used at each attachment point of the resilient channels and spaced max 24 in. O.C. Channel ends butted and centered under the structural members and attached with one accessory at each end. Additional accessories used to hold resilient channels that support the gypsum board end joints. The accessory envelops the mounting edge of the resilient channel. The accessory and resilient channel are fastened to the structural members with the screws supplied with the accessory and per the accessory manufacturer's installation instructions.

**PAC INTERNATIONAL L L C** — Types RC-1 Boost

6. **Gypsum Board\*** — Two layers of 1/2 in. thick each, 4 ft wide gypsum board. When resilient channels (Item 5) are used, both layers installed with long dimension perpendicular to resilient channels. Butted end joints of base layer centered on 60 in. long pieces of resilient channels (Item 5). Base layer fastened to resilient channels with 1 in. long No. 6 Type S bugle head steel screws. Screws spaced 8 in. OC at butted end joints and 16 in. OC along continuous rows of channels in the field of the boards. Screws to be spaced 1/2 in. from butted end joints and 1 in. from side joints. Face layer installed with its side joints offset min 10 in. from side joints of base layer. Butted end joints staggered min 32 in. in adjacent rows and offset min 16 in. from butted end joints of base layer. Face layer fastened to continuous rows of resilient channels through base layer with 1-5/8 in. long No. 6 Type S bugle head steel screws spaced 8 in. OC. At butted end joints, face layer fastened to base layer with 1-1/2 in. long Type G screws spaced 8 in. OC on each side of end joint. Fasteners spaced 1/2 and 1 in. from butted end and side joints, respectively. When **Steel Framing Members\*** (Item 5A, 5D) are used, sheets installed with long dimensions parallel with joists. Base layer attached to the furring channels using 1 in. long No. 6 Type S bugle head steel screws spaced 8 in. OC along butted end joints and 12 in. OC in the field of the board. Butted end joints shall be staggered min 2 ft. within the assembly, and occur midway between the continuous furring channels. Each end of each gypsum board shall be supported by a single length of furring channel equal to the width of the board plus 6 in. on each end. The two furring channels shall be spaced approximately 3-1/2 in. OC, and be attached to underside of the joist with one clip at each end of the channel. Butted base layer end joints to be offset a min of 24 in. in adjacent courses. Outer layer attached to the furring channels

using 1-5/8 in. long No. 6 Type S bugle head steel screws spaced 8 in. OC at butted joints and 12 in. OC in the field. Butted end joints to be offset a min of 8 in. from base layer end joints. Butted side joints of outer layer to be offset min 18 in. from butted side joints of base layer. When **Steel Framing Members** (Item 5B) are used, panels installed with long dimension parallel with joists. Base layer attached to the furring channels using 1 in. long Type S bugle-head steel screws spaced 8 in. OC along butted end joints and 12 in. OC in the field of the panels. Butted end joints shall be staggered min. 2 ft. within the assembly, and occur midway between the continuous furring channels. Each end of the gypsum panels shall be supported by a single length of furring channel equal to the width of the panel plus 6 in. on each end. The furring channels shall be spaced approximately 3-1/2 in. OC, and be attached to underside of the joist with one Genie clip at each end of the channel. Butted base layer end joints to be offset a minimum of 24 in. in adjacent courses. Outer layer attached to the furring channels using 1-5/8 in. long Type S bugle-head steel screws spaced 8 in. OC at butted joints and 12 in. OC in the field. Butted end joints to be offset min 12 in. from base layer end joints. Butted side joints of outer layer to be offset min 12 in. from butted side joints of base layer.

When **Steel Framing Members** (Item 5C) are used, base layer gypsum board is installed with long dimensions perpendicular to furring channels. Gypsum board secured to furring channels with nom 1 in. long Type S bugle-head steel screws spaced 8 in. OC in the field of the board. Gypsum board butted end joints shall be staggered minimum 48 in. and centered over main furring channels. At the gypsum board butt joints, each end of each gypsum board shall be supported by a single length of furring channel equal to the width of the gypsum board plus 3 in. on each end. The two support furring channels shall be spaced approximately 3 in. in from joint. Screw spacing along the gypsum board butt joint and along both additional channels shall be 8 in. OC. Additional screws shall be placed in the adjacent section of gypsum board into the aforementioned 3 in. extension of the extra butt joint channels as well as into the main channel that runs between. Butt joint furring channels shall be attached with one RESILMOUNT Sound Isolation Clip at each end of the channel. Face layer secured per Item 6.

When **Steel Framing Members** (Item 5E) are used, two layers of nom 1/2 in. thick, 4 ft wide gypsum board, installed as described in Item 6. Adjacent butt joints staggered minimum 48 in. OC.

When **Steel Framing Members** (Item 5F) are used, two layers of nom 1/2 in. thick, 4 ft wide gypsum board, installed as described in Item 6. Butt joints staggered minimum 24 in. OC.

**AMERICAN GYPSUM CO** — Type AG-C

**CERTAINEED GYPSUM INC** — Type C

**CERTAINEED GYPSUM INC** — Type LGFC-C/A

**GEORGIA-PACIFIC GYPSUM L L C** — Types 5, C, DAP, DA, DAPC, TG-C

**THAI GYPSUM PRODUCTS PCL** — Type FRPC, Type C

7. **Finishing System - (Not Shown)** — For second layer of gypsum board. Vinyl, dry or premixed joint compound, applied in two coats to joints and screw-heads. Nom 2 in. wide paper tape embedded in first layer of compound over all joints. As an alternate, nom 3/32 in. thick veneer plaster may be applied to the entire surface of gypsum board.

**\* Indicates such products shall bear the UL or cUL Certification Mark for jurisdictions employing the UL or cUL Certification (such as Canada), respectively.**

Last Updated on 2022-02-14