

Design No. **L505**
 April 04, 2023

Unrestrained Assembly Rating — 2 Hr.
Finish Rating — 75 Min.

This design was evaluated using a load design method other than the Limit States Design Method (e.g., Working Stress Design Method). For jurisdictions employing the Limit States Design Method, such as Canada, a load restriction factor shall be used — See Guide [BXUV](#) or [BXUV7](#)

* Indicates such products shall bear the UL or cUL Certification Mark for jurisdictions employing the UL or cUL Certification (such as Canada), respectively.

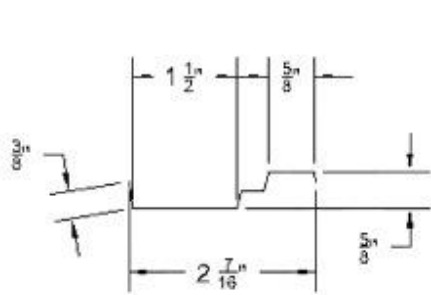
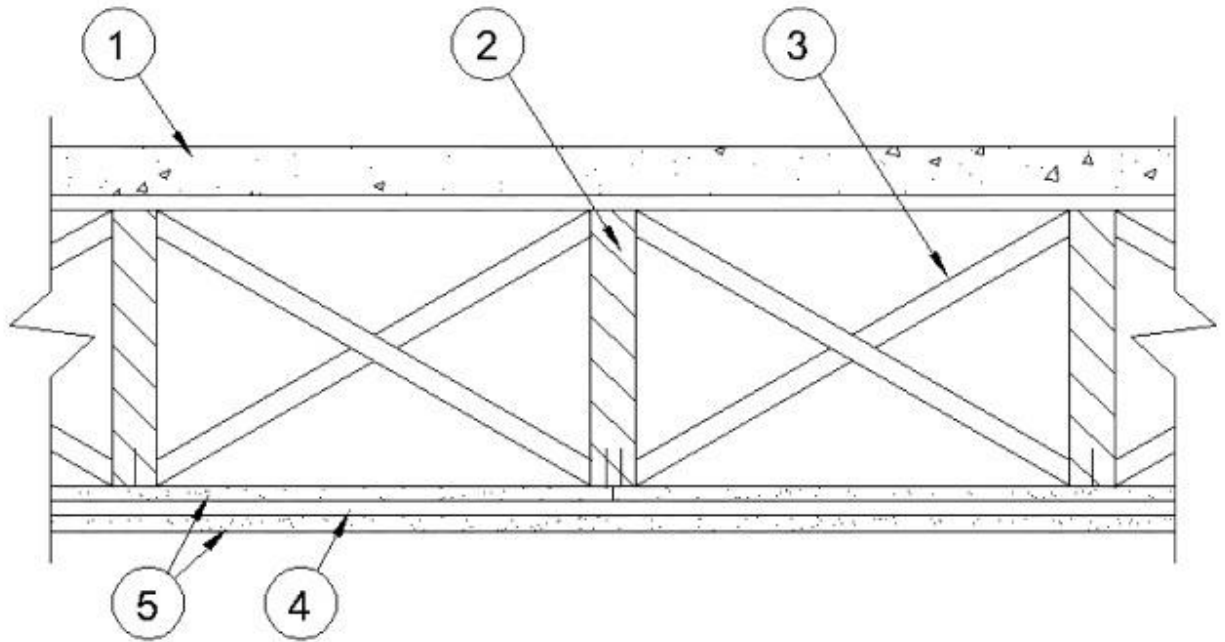

Resilient Channel Detail

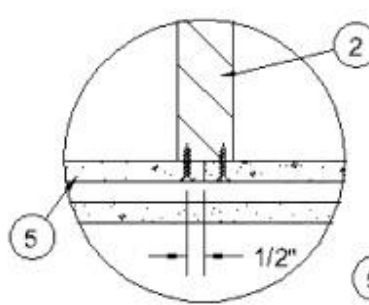

First Layer End Joint Detail

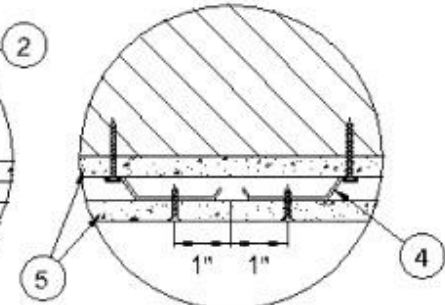

Second Layer End Joint Detail

1. **Flooring System** — The flooring system shall consist of one of the following:
System No. 1

Subflooring — Min 1 by 6 in. T & G lumber fastened diagonally to joists, or min 15/32 in. thick wood structural panels or 7/16 in. thick oriented strand board (OSB) wood structural panels, min grade "C-D" or "Sheathing". Face grain of plywood or strength axis of panels to be perpendicular to the joists with joints staggered.

Vapor Barrier — Nom 0.010 in. thick commercial rosin-sized building paper.

Finish Flooring — Min 1 by 4 in. T & G lumber fastened perpendicular to joists, or min 19/32 in. wood structural panels, min grade "Underlayment" or "Single Floor". Face grain of plywood or strength axis of panels to be perpendicular to joists with joints staggered.

System No. 2

Subflooring — Min 15/32 in. thick wood structural panels, min grade "C-D" or "Sheathing". Face grain of plywood or strength axis of panels to be perpendicular to the joists with joints staggered.

Vapor Barrier - (Optional) — Nom 0.010 in. thick commercial asphalt saturated felt.

Finish Flooring - Floor Topping Mixture* — Min 3/4 in. thickness of floor topping mixture having a minimum compressive strength of 1800 psi. Refer to manufacturer's instructions accompanying the material for specific mix design.

UNITED STATES GYPSUM CO — Types LRK, HSLRK, CSD

USG MEXICO S A DE C V — Types LRK, HSLRK, CSD

Floor Mat Materials* — (Optional) - Floor mat material loose laid over the subfloor. Refer to manufacturer's instructions regarding the minimum thickness of floor topping over each floor mat material.

UNITED STATES GYPSUM CO — Types SAM, LEVELROCK® Brand Sound Reduction Board, LEVELROCK® Brand Floor Underlayment SRM-25

Alternate Floor Mat Materials* - (Optional) — Nom 3/8 in. thick floor mat material loose laid over the subfloor. Floor topping thickness shall be as specified under **Floor Topping Mixture**.

GRASSWORX L L C — Type SC50

Alternate Floor Mat Material* — (Optional) - Floor mat material nominal 3/8 in. thick loose laid over the subfloor. Floor topping shall be a min 3/4 or 1 in. thickness of floor topping mixture for min 19/32 or min 15/32 in. thick wood structural panels respectively.

System No. 3

Subflooring — Min 15/32 in. thick wood structural panels, min grade "C-D" or "Sheathing". Face grain of plywood or strength axis of panels to be perpendicular to the joists with joints staggered.

Vapor Barrier - (Optional) — Nom 0.030 in thick commercial asphalt saturated felt.

Finish Flooring - Floor Topping Mixture* — Min 1-1/2 in. thickness of floor topping mixture having a min compressive strength of 1000 psi and a cast density of 100 plus or minus 5 pcf. Foam concentrate mixed 40:1 by volume with water and expanded at 100 psi through nozzle. Mixture shall consist of 1.4 cu feet of preformed foam concentrate to 94 lbs Type I Portland cement, 300 lbs of sand with 5-1/2 gal of water.

ELASTIZELL CORP OF AMERICA — Type FF

System No. 4

Subflooring — Min 15/32 in. thick wood structural panels, min grade "C-D" or "Sheathing". Face grain of plywood or strength axis of panels to be perpendicular to the joists with joints staggered.

Vapor Barrier - (Optional) — Nom 0.030 in thick commercial asphalt saturated felt.

Floor Mat Materials* - (Optional) — Floor mat material nom 5/64 in. (2 mm) thick adhered to subfloor with Hacker Floor Primer. Primer to be applied to the surface of the mat prior to the placement of a min 1-1/4 in. of floor-topping mixture.

HACKER INDUSTRIES INC — Type Hacker Sound-Mat.

Alternate Floor Mat Materials - (Optional) — Floor mat material nom 1/4 in. (6 mm) thick adhered to subfloor with Hacker Floor Primer. Primer to be applied to the surface of the mat prior to the placement of a min 1-1/4 in. (32 mm) of floor-topping mixture.

HACKER INDUSTRIES INC — Type Hacker Sound-Mat II.

Alternate Floor Mat Materials - (Optional) — Floor mat material nom 1/8 in. (3 mm) thick loose laid over the subfloor. Floor topping thickness shall be a min of 1 in. (25 mm)

HACKER INDUSTRIES INC — FIRM-FILL SCM 125

Alternate Floor Mat Materials - (Optional) — Floor mat material nom 1/4 in. (6 mm) thick loose laid over the subfloor. Floor topping thickness shall be a min of 1 in. (25 mm)

HACKER INDUSTRIES INC — Type FIRM-FILL SCM 250, Quiet Qurl 55/025

Alternate Floor Mat Materials - (Optional) — Floor mat material nom 3/8 in. (10 mm) thick loose laid over the subfloor. Floor topping thickness shall be a min of 1-1/4 in. (32 mm)

HACKER INDUSTRIES INC — FIRM-FILL SCM 400, Quiet Qurl 60/040

Alternate Floor Mat Materials - (Optional) — Floor mat material nom 3/4 in. (19 mm) thick loose laid over the subfloor. Floor topping thickness shall be a min of 1-1/2 in. (38 mm)

HACKER INDUSTRIES INC — Type FIRM-FILL SCM 750, Quiet Qurl 65/075

Metal Lath (Optional) — For use with 3/8 in. (10 mm) floor mat materials, 3/8 in. expanded steel diamond mesh, 3.4 lbs/sq yd placed over the floor mat material. Hacker Floor Primer to be applied prior to the placement of the metal lath. When metal lath is used, floor topping thickness a nom 1-1/4 in. over the floor mat.

Finish Flooring - Floor Topping Mixture* — Min 3/4 or 1 in. thickness of floor topping mixture for min 19/32 or min 15/32 in. thick wood structural panels respectively, having a min compressive strength of 1100 psi. Mixture shall consist of 6.8 gal of water to 80 lbs of floor topping mixture to 1.9 cu ft of sand.

HACKER INDUSTRIES INC — Firm-Fill Gypsum Concrete, Firm-Fill 2010, Firm-Fill 3310, Firm-Fill 4010, Firm-Fill High Strength, Gyp-Span Radiant

System No. 5

Deleted.

System No. 6

Subflooring — Min 15/32 in. thick wood structural panels, min grade "C-D" or "Sheathing". Face grain of plywood or strength axis of panels to be perpendicular to the joists with joints staggered.

Vapor Barrier - (Optional) — Nom 0.030 in thick commercial asphalt saturated felt.

Finish Flooring - Floor Topping Mixture* — Min 3/4 or 1 in. thickness of floor topping mixture for 19/32 or 15/32 in. thick wood structural panels respectively, having a min compressive strength of 1000 psi. Mixture shall consist of 5 to 8 gal of water to 80 lbs of floor topping mixture to 2.1 cu ft of sand.

ULTRA QUIET FLOORS — UQF-A, UQF-Super Blend, UQF-Plus 200

System No. 7

Subflooring — Min 15/32 in. thick wood structural panels, min grade "C-D" or "Sheathing". Face grain of plywood or strength axis of panels to be perpendicular to the joists with joints staggered.

Vapor Barrier - (Optional) — Nom 0.030 in thick commercial asphalt saturated felt.

Finish Flooring - Floor Topping Mixture* — Min 3/4 in. thickness of floor topping mixture having a minimum compressive strength of 1500 psi. Refer to manufacturer's instructions accompanying the material for specific mix design.

MAXXON CORP — Type Maxxon Standard and Maxxon High Strength

Floor Mat Materials* - (Optional) — Floor mat material loose laid over the subfloor. Refer to manufacturer's instructions regarding the minimum thickness of floor topping over each floor mat material.

MAXXON CORP — Type Encapsulated Sound Mat.

Floor Mat Reinforcement - (Optional) - Refer to manufacturer's instructions regarding minimum thickness of floor topping for use with floor mat reinforcement.

Metal Lath — (Optional) — 3/8 in. expanded galvanized steel diamond mesh, 3.4 lbs/sq yd loose laid over the floor mat material.

Fiber Glass Reinforcement - (Optional, Not Shown) - 0.015 in. thick PVC coated non-woven fiberglass mesh, 0.368 lbs/sq yd loose laid over the floor mat material.

System No. 8

Subflooring — Min 15/32 in. thick wood structural panels, min grade "C-D" or "Sheathing". Face grain of plywood or strength axis of panels to be perpendicular to the joists with joints staggered.

Vapor Barrier — (Optional) — Nom 0.010 in. thick commercial rosin-sized building paper.

Finish Flooring — Floor Topping Mixture* — Min 3/4 in. thickness of floor topping mixture having a minimum compressive strength of 1500 psi. Refer to manufacturer's instructions accompanying the material for specific mix design.

FORMULATED MATERIALS LLC — Types FR-25, FR-30, and SiteMix.

Alternate Floor Mat Material* — (Optional) — Floor mat material nominal 2 - 9.5 mm thick loose laid over the subfloor. Floor topping thickness shall be a minimum of 3/4 in.

FORMULATED MATERIALS LLC — Types M1, M2, M3, Elite, Duo, R1, and R2.

System No. 9

Subflooring — Min 1 by 6 in. T & G lumber fastened diagonally to joists, or min 15/32 in. thick wood structural panels or 7/16 in. thick oriented strand board (OSB) wood structural panels, min grade "C-D" or "Sheathing". Face grain of plywood or strength axis of panels to be perpendicular to the joists with joints staggered.

Finish Floor - Mineral and Fiber Board* — Min 1/2 in. thick, supplied in sizes ranging from 3 ft by 4 ft to 8 ft by 12 ft. All joints to be staggered a min of 12 in. with adjacent sub-floor joints.

HOMASOTE CO — Type 440-32 Mineral and Fiber Board

System No. 10

Subflooring — Min 15/32 in. thick wood structural panels, min grade "C-D" or "Sheathing". Face grain of plywood or strength axis of panels to be perpendicular to the joists with joints staggered.

Vapor Barrier - (Optional) — Nom 0.030 in thick commercial asphalt saturated felt.

Finish Flooring - Floor Topping Mixture* — Min 1-1/2 in. thickness of floor topping mixture having a min compressive strength of 1000 psi and a cast density of 105 plus or minus 5 pcf. Foam concentrate mixed 40:1 by volume with water and expanded at 100 psi through nozzle. Mixture shall consist of 1.2 cu feet of preformed foam concentrate to 94 lbs Type I Portland cement, 300 lbs of sand with 5.5 gal of water.

AERIX INDUSTRIES — Floor-Topping Mixture

System No. 11

Subflooring — Min 15/32 in. thick wood structural panels, min grade "C-D" or "Sheathing". Face grain of plywood or strength axis of panels to be perpendicular to the joists with joints staggered.

Vapor Barrier - (Optional) — Nom 0.010 in. thick commercial rosin-sized building paper.

Finish Flooring - Floor Topping Mixture* — Min 3/4 or 1 in. thickness of floor topping mixture for 19/32 or 15/32 in. thick wood structural panels respectively, having a min compressive strength of 1000 psi. Refer to manufacturer's instructions accompanying the material for specific mix design.

ARCOSA SPECIALTY MATERIALS — AccuCrete® Types NexGen, Green, Prime and PrePour, AccuRadiant®, AccuLevel® Types G40, G50 and SD30

Alternate Floor Mat Material* - (Optional) - Floor mat material nominal 2 - 9.5 mm thick loose laid over the subfloor. Floor topping shall be a min of 3/4 in. or 1 in. thick of floor topping mixture for 19/32 or 15/32 in. thick wood structural panels respectively.

ARCOSA SPECIALTY MATERIALS — AccuQuiet® Types D13, D-18, D25, DX38, EM.125, EM.125S, EM.250, EM.250S, EM.375, EM.375S, EM.750, and EM.750S.

System No. 12

Subflooring — 15/32 or 19/32 in. thick wood structural panels, min. grade "C-D" or "Sheathing". Face grain of plywood or strength axis of panels to be perpendicular to joists with joints staggered.

Vapor Barrier — (Optional) — Nom 0.030 in. thick commercial asphalt saturated felt.

Finish Flooring — Floor Topping Mixture* — Min 3/4 or 1 in. thickness of floor topping mixture for 19/32 or 15/32 in. thick wood structural panels respectively, having a min compressive strength of 2100 psi. Refer to manufacturer's instructions accompanying the material for specific mix design.

System No. 13

Subflooring — Min 15/32 in. thick wood structural panels, min grade "C-D" or "Sheathing". Face grain of plywood or strength axis of panels to be perpendicular to the joists with joints staggered.

Vapor Barrier — (Optional) - Commercial asphalt saturated felt, 0.030 in. thick.

Vapor Barrier — (Optional) - Nom 0.010 in. thick commercial rosin-sized building paper.

Finish Flooring* — Min 3/4 in. thickness of any Floor Topping Mixture bearing the UL Classification Marking as to Fire Resistance. See Floor- and Roof-Topping Mixtures (CCOX) category for names of Classified Companies.

Floor Mat Materials* — (Optional) - Nom. 1/4 in. thick loose laid over the subfloor. Floor topping thickness shall be a minimum of 3/4 in.

KEENE BUILDING PRODUCTS CO INC — Type Quiet Qurl 55/025 and Quiet Qurl 55/025 N

Alternate Floor Mat Materials* — (Optional) - Floor mat material Nom. 3/8 in. thick loose laid over the subfloor. Floor topping thickness shall be a minimum of 1 in.

KEENE BUILDING PRODUCTS CO INC — Type Quiet Qurl 60/040 and Quiet Qurl 60/040 N

Alternate Floor Mat Materials* — (Optional) - Floor mat material Nom. 3/4 in. thick loose laid over the subfloor. Floor topping thickness shall be a minimum of 1-1/2 in.

KEENE BUILDING PRODUCTS CO INC — Type Quiet Qurl 65/075, Quiet Qurl 65/075 N

Alternate Floor Mat Materials* — (Optional) - Floor mat material Nom. 1/8 in. thick loose laid over the subfloor. Floor topping thickness shall be a minimum of 3/4 in.

KEENE BUILDING PRODUCTS CO INC — Type Quiet Qurl 52/013 and Quiet Qurl 52/013 N

Alternate Floor Mat Materials* — (Optional) - Floor mat material Nom. 1/4 in. entangled net core with a compressible fabric attached to the bottom loose laid over the subfloor. Floor topping thickness shall be a minimum of 1 in.

KEENE BUILDING PRODUCTS CO INC — Quiet Qurl 55/025 MT and Quiet Qurl 55/025 N MT

System No. 14

Subflooring — Min 15/32 in. thick wood structural panels, min grade "C-D" or "Sheathing". Face grain of plywood or strength axis of panels to be perpendicular to the joists with joints staggered.

Vapor Barrier - (Optional) — Nom 0.010 in. thick commercial rosin-sized building paper.

Finish Flooring - Floor Topping Mixture* — Min 3/4 or 1 in. thickness of floor topping mixture for 19/32 or 15/32 in. thick wood structural panels respectively, having a min compressive strength of 1000 psi. Refer to manufacturer's instructions accompanying the material for specific mix design.

DEPENDABLE LLC — GSL M3.4, GSL K2.6, GSL-CSD and GSL RH.

Floor Mat Materials* — (Optional) - Nom. 1/4 in. thick loose laid over the subfloor. Floor topping thickness shall be a minimum of 3/4 in.

KEENE BUILDING PRODUCTS CO INC — Type Quiet Qurl 55/025 and Quiet Qurl 55/025 N

Alternate Floor Mat Materials* — (Optional) - Floor mat material Nom. 3/8 in. thick loose laid over the subfloor. Floor topping thickness shall be a minimum of 1 in.

KEENE BUILDING PRODUCTS CO INC — Type Quiet Qurl 60/040 and Quiet Qurl 60/040 N

Alternate Floor Mat Materials* — (Optional) - Floor mat material Nom. 3/4 in. thick loose laid over the subfloor. Floor topping thickness shall be a minimum of 1-1/2 in.

KEENE BUILDING PRODUCTS CO INC — Type Quiet Qurl 65/075, Quiet Qurl 65/075 N

Alternate Floor Mat Materials* — (Optional) - Floor mat material Nom. 1/8 in. thick loose laid over the subfloor. Floor topping thickness shall be a minimum of 3/4 in.

KEENE BUILDING PRODUCTS CO INC — Type Quiet Qurl 52/013 and Quiet Qurl 52/013 N

Alternate Floor Mat Materials* — (Optional) - Floor mat material Nom. 1/4 in. entangled net core with a compressible fabric attached to the bottom loose laid over the subfloor. Floor topping thickness shall be a minimum of 1 in.

KEENE BUILDING PRODUCTS CO INC — Quiet Qurl 55/025 MT and Quiet Qurl 55/025 N MT

System No. 15

Subflooring — Min 15/32 in. thick wood structural panels, min grade "C-D" or "Sheathing". Face grain of plywood or strength axis of panels to be perpendicular to the joists with joints staggered.

Vapor Barrier — (Optional) - Commercial asphalt saturated felt, 0.030 in. thick.

Vapor Barrier — (Optional) - Nom 0.010 in. thick commercial rosin-sized building paper.

Finish Flooring* — Min 3/4 in. thickness of any Floor Topping Mixture bearing the UL Classification Marking as to Fire Resistance. See Floor- and Roof-Topping Mixtures (CCOX) category for names of Classified Companies.

Floor Mat Materials* — (Optional) - Nom 3/32 in. thick loose laid over the subfloor. Floor topping thickness shall be a minimum of 3/4 in.

PLITEQ INC — Type GenieMat RST02

Floor Mat Materials* — (Optional) - Nom 3/16 in. thick loose laid over the subfloor. Floor topping thickness shall be a minimum of 3/4 in.

PLITEQ INC — Type GenieMat FF03NP

Floor Mat Materials* — (Optional) - Nom 1/4 in. thick loose laid over the subfloor. Floor topping thickness shall be a minimum of 3/4 in.

PLITEQ INC — Type GenieMat FF06

Floor Mat Materials* — (Optional) - Nom 3/8 in. thick loose laid over the subfloor. Floor topping thickness shall be a minimum of 1 in.

PLITEQ INC — Type GenieMat FF10

Floor Mat Materials* — (Optional) - Nom 3/4 in. thick loose laid over the subfloor. Floor topping thickness shall be a minimum of 1-1/2 in.

PLITEQ INC — Type GenieMat FF17

Floor Mat Materials* — (Optional) - Nom 1 in. thick loose laid over the subfloor. Floor topping thickness shall be a minimum of 1-1/2 in.

PLITEQ INC — Type GenieMat FF25

System No. 16

Subflooring — Building Units* — Nom 3/4 in. thick, tongue and grooved boards. Long dimension of boards to be perpendicular to joists with end joints staggered a min of 4 ft. and centered over the joists. Boards secured to joists with 2 in. long self-drilling, self-tapping screws or 2 in. x 0.113 in. Ring Shank nails spaced a max of 12 in. OC in the field with screws/nails located 1 in. from long edge, and max 8 in. OC along the end joints with screws/nails located 1/2 in. from end joint.

ECTEK INTERNATIONAL INC — Type MegaBoard

Vapor Barrier — Nom 0.010 in. thick commercial rosin-sized building paper.

Finish Flooring — Min 1 by 4 in. T & G lumber fastened perpendicular to joists, or min 19/32 in. wood structural panels, min grade "Underlayment" or "Single Floor". Face grain of plywood or strength axis of panels to be perpendicular to joists with joints staggered.

System No. 17

Subflooring — Min 15/32 in. thick wood structural panels or 7/16 in. thick oriented strand board (OSB) wood structural panels, min grade "C-D" or "Sheathing". Face grain of plywood or strength axis of panels to be perpendicular to the joists with joints staggered.

Wall and Partition Facings and Accessories* - Sound Barrier (Optional) — Acoustic Sleeper pads stapled to the top of the bottom of the finish floor, or to 5/16 in. thick by 1-1/2 in. wide wood strips and centered over wood joist. Acoustic Sleeper pads are to be spaced appropriately so that the finish floor panels are fastened through Acoustic Sleeper pads to the joist.

STC ARCHITECTURAL PRODUCTS L L C DBA STC SOUND CONTROL — Acoustic Sleeper

Finish Flooring — Min 19/32 in. wood structural panels, min grade "Underlayment" or "Single Floor". Face grain of plywood or strength axis of panels to be perpendicular to joists with joints staggered. Butt joints of panels have the option of being sealed with any UL Classified caulk or sealant found under - Fill, Void or Cavity Materials* (XHHW).

System No. 18

Subflooring — Min 1 by 6 in. T & G lumber fastened diagonally to joists, or min 15/32 in. thick wood structural panels or 7/16 in. thick oriented strand board (OSB) wood structural panels, min grade "C-D" or "Sheathing". Face grain of plywood or strength axis of panels to be perpendicular to the joists with joints staggered.

Finish Flooring - Floor Topping Mixture* — Min 1 in. thickness of floor topping mixture having a min compressive strength of 4500 psi. Refer to manufacturer's instructions accompanying the material for specific mix design.

SIKA DEUTSCHLAND GMBH — Type SCHONOX AP Rapid Plus

System No. 19

Subflooring — Min 1 by 6 in. T & G lumber fastened diagonally to joists, or min 15/32 in. thick wood structural panels or 7/16 in. thick oriented strand board (OSB) wood structural panels, min grade "C-D" or "Sheathing". Face grain of plywood or strength axis of panels to be perpendicular to the joists with joints staggered.

Vapor Barrier — (Optional) - Commercial asphalt saturated felt, 0.030 in. thick.

Vapor Barrier — (Optional) - Nom 0.010 in. thick commercial rosin-sized building paper.

Finish Flooring - Floor Topping Mixture* — Min 3/4 in. thickness of any Floor Topping Mixture bearing the UL Classification Marking as to Fire Resistance. See Floor- and Roof-Topping Mixtures (CCOX) category for names of Classified Companies. Refer to the manufacturer's instructions accompanying the material and/or contact the manufacturer's technical support for specific mix design and minimum thickness recommended for use with eligible floor mat(s).

Floor Mat Materials* — (Optional, Not Shown) - Floor mat material loose laid over the subfloor. Refer to manufacturer's instructions regarding the minimum thickness of floor topping over each floor mat material.

LOW & BONAR INC — EnkaSonic® by Colbond a member of the Low & Bonar group Types 125, 250, 250 Plus, 400, 400 Plus, 750, and 750 Plus.

Floor Mat Reinforcement — (Optional) - Refer to manufacturer's instructions regarding minimum thickness of floor topping for use with floor mat reinforcement.

Metal Lath — (Optional) — Expanded steel diamond mesh, 2.5 lb / sq yd loose laid over floor mat material.

Fiberglass Mesh Reinforcement — (Optional) — Coated non-woven glass fiber mesh grid loose laid over floor mat material.

2. **Wood Joists** — Min 2 by 10, spaced 16 in. OC and effectively fireblocked in accordance with local codes.

3. **Cross Bridging** — Min 1 by 3 in. or min 2 by 10 solid blocking.

4. **Resilient Channels** — Resilient channels, formed from No. 25 MSG galv steel and shaped as shown, spaced 24 in. OC perpendicular to joist. Channels overlapped 1-1/2 in. at splices and secured to each joist with one 8d common nail. Min end clearance of channels to wall to be 3/4 in. Additional pieces, 60 in. long, placed immediately adjacent to continuous channels at end joints of second layer of gypsum board (Item 5) and similarly secured. Additional channels shall extend 6 in. beyond each side edge of board.

4A. **Steel Framing Members** — As an alternate to Item 4, furring channels and **Steel Framing Members*** as described below:

a. **Furring Channels** — Furring channels, formed of No. 25 MSG galv steel, 2-9/16 in. or 2-23/32 in. wide by 7/8 in. deep, spaced 24 in. OC perpendicular to joists. Channels secured to joists as described in Item b. Ends of adjoining channels overlapped 6 in. and tied together with double strands of No. 18 SWG galv steel wire near each end of overlap.

b. **Steel Framing Members*** — Used to attach furring channels (Item a) to joists (Item 2). Clips spaced 48 in. OC., and secured to alternating joists with No. 8 x 2-1/2 in. coarse drywall screw through the center grommet. Furring channels are friction fitted into clips. RSIC-1 clip for use with 2-9/16 in. wide furring channels. RSIC-1 (2.75) clip for use with 2-23/32 in. wide furring channels. Adjoining channels are overlapped as described in Item a. As an alternate, ends of adjoining channels may be overlapped 6 in. and secured together with two self-tapping #6 framing screws, min. 7/16 in. long at the midpoint of the overlap, with one screw on each flange of the channel. Additional clips required to hold furring channel that supports the wallboard butt joints, as described in Item 5.

PAC INTERNATIONAL L L C — Types RSIC-1, RSIC-1 (2.75).

4B. **Steel Framing Members*** — (Not Shown) - As an alternate to items 4, furring channels and Steel Framing Members as described below.

a. **Furring Channels** — Formed of No. 25 MSG galv steel, 2-3/8 in. wide by 7/8 in deep, spaced 24 in OC, perpendicular to joists. Channels secured to joists as described in Item b. Ends of adjoining channels overlapped 6 in. and tied together with double strand of No. 18 SWG galv steel wire near each end of overlap.

b. **Steel Framing Members*** — Used to attach furring channels (Item a) to the wood joists (Item 2). Clips spaced 48 in. OC., and secured to alternating joists with No. 8 x 2-1/2 in. coarse drywall screw through the center grommet. Furring channels are friction fitted into clips. Adjoining channels are overlapped as described in Item a. As an alternate, ends of adjoining channels may be overlapped 6 in. and secured together with two self-tapping No. 6 framing screws, min 7/16 in. long at the midpoint of the overlap, with one screw on each flange of the channel. Additional clips required to hold furring channel that supports the gypsum board butt joints, as described in Item 5.

PLITEQ INC — Type Genie Clip

4C. **Alternate Steel Framing Members*** — (Not Shown) - As an alternate to Item 4, furring channels and Steel Framing Members as described below.

a. **Furring Channels** — Formed of No. 25 MSG galv steel, 2-5/8 in. wide by 7/8 in deep, spaced 24 in OC, perpendicular to joists. Channels secured to joists as described in Item b.

b. **Steel Framing Members*** — Used to attach furring channels (Item a) to the wood joists (Item 2). Clips spaced at 48 in. OC and secured to the bottom of the joists with one 2 in. Coarse Drywall Screw with 1 in. diam washer through the center hole. Furring channels are then friction fitted into clips. Ends of channels are overlapped 6" and tied together with double strand of No. 18 AWG galvanized steel wire. Additional clips are required to hold the Gypsum Butt joints as described in Item 5.

STUDCO BUILDING SYSTEMS — RESILMOUNT Sound Isolation Clips - Type A237R

4D. **Alternate Steel Framing Members*** — (Not Shown) - As an alternate to Item 4, furring channels and Steel Framing Members as described below.

a. **Furring Channels** — Formed of No. 25 MSG galv steel, 2-1/2 in. wide by 7/8 in deep, spaced 24 in OC, perpendicular to joists. Channels secured to joists as described in Item b.

b. **Steel Framing Members*** — Used to attach furring channels (Item a) to the wood joists (Item 2). Clips spaced at 48 in. OC and secured to the bottom of the joists with one 2-1/2 in. Coarse Drywall Screw with 1 in. diam washer through the center hole. Furring channels are then friction fitted into clips. Ends of channels are overlapped 6" and tied together with double strand of No. 18 AWG galvanized steel wire. Additional clips are required to hold the Gypsum Butt joints as described in Item 5.

REGUPOL AMERICA — Type SonusClip

5. **Gypsum Board*** — Two layers 5/8 in. thick gypsum board. When resilient channels (Item 4) are used, first layer installed with long dimension perpendicular to joists, and end joints of boards located at the joists. Nailed to joists with uncoated 8d box nails spaced 7 in. OC. All nails located 1/2 in. min distance from the edges and ends of the board. Second layer installed with long dimension perpendicular to the resilient channels and center line of boards located under a joist and so placed that the edge joint of this layer is not in alignment with the end joint of the first layer. Secured to resilient channels with 1 in. long gypsum board screws 12 in. OC with additional screws 3 in. from side joints. End joints secured to both resilient channels as shown in end joint detail. All screws located 1 in. min distance from edges of boards. If gypsum board is other than 48 in. wide, length of additional channel may be modified as required to allow full extension along joints, as well as attachment to joists at each end. Joint treatment not required for this rating, except for tapered, rounded-edge gypsum board where edge joints are covered with paper tape and joint compound. As an alternate, nom 3/32 in. thick gypsum veneer plaster may be applied to the entire surface of Classified veneer baseboard. Joints reinforced.

When **Steel Framing Members** (Items 4A or 4B) are used, sheets installed with long dimensions parallel with joists. Base layer attached to the furring channels using 1 in. long Type S bugle-head steel screws spaced 8 in. OC along butted end joints and 12 in. OC in the field of the board. Butted end joints shall be staggered min 2 ft. within the assembly, and occur midway between the continuous furring channels. Each end of each gypsum board shall be supported by a single length of furring channel equal to the width of the gypsum board plus 6 in. on each end. The two furring channels shall be spaced approximately 3-1/2 in. OC, and be attached to underside of the joist with one RSIC-1 or Genie clip at each end of the channel. Butted base layer end joints to be offset a min of 24 in. in adjacent courses. Outer layer attached to the furring channels using 1-5/8 in. long Type S bugle-head steel screws spaced 8 in. OC at butted joints and 12 in. OC in the field. Butted end joints to be offset a min of 8 in. from base layer end joints. Butted side joints of outer layer to be offset min 18 in. from butted side joints of base layer.

When **Steel Framing Members** (Item 4C) are used, base layer of nom 5/8 in. thick, 4 ft wide gypsum board is installed with long dimensions perpendicular to furring channels. Gypsum board secured to furring channels with nom 1 in. long Type S bugle-head steel screws spaced 8 in. OC in the field of the board. Gypsum board butted end joints shall be staggered minimum 48 in. and centered over main furring channels. At the gypsum board butt joints, each end of each gypsum board shall be supported by a single length of furring channel equal to the width of the gypsum board plus 3 in. on each end. The two support furring channels shall be spaced approximately 3 in. in from joint. Screw spacing along the gypsum board butt joint and along both additional channels shall be 8 in. OC. Additional screws shall be placed in the adjacent section of gypsum board into the aforementioned 3 in. extension of the extra butt joint channels as well as into the main channel that runs between. Butt joint furring channels shall be attached with one RESILMOUNT Sound Isolation Clip at each end of the channel. Face layer attached per Item 5.

When **Steel Framing Members** (Item 4D) are used, base layer of nom 5/8 in. thick, 4 ft wide gypsum board is installed with long dimensions perpendicular to furring channels. Gypsum board secured to furring channels with nom 1 in. long Type S bugle-head steel screws spaced 8 in. OC in the field of the board. Gypsum board butted end joints shall be staggered minimum 48 in. and centered over main furring channels. At the gypsum board butt joints, an additional single length of furring channel shall be installed and be spaced approximately 3 in. from the butt joint (6 in. from the continuous furring channels) to support the floating end of the gypsum board. Each of these shorter sections of furring channel shall extend one joist beyond the width of the gypsum panel and be attached to the adjacent joists with one SonusClip at every joist involved with the butt joint.

AMERICAN GYPSUM CO — Type AG-C.

CERTAINTeed GYPSUM INC — Type C, Type LGFC-C/A.

GEORGIA-PACIFIC GYPSUM L L C — Types 5, C, DAPC, GPFS1, TG-C.

NATIONAL GYPSUM CO — Types FSK-C, FSK-G, FSW-C, FSW-G

PABCO BUILDING PRODUCTS L L C, DBA PABCO GYPSUM — Type C, PG-3 or PG-C

THAI GYPSUM PRODUCTS PCL — Type C

6. **Screw, Gypsum Board** — 1 in. long, with 0.129 in., self-drilling and self-tapping shank, and Phillips-type 0.355 in. diam head. Screws shall be driven no farther than slightly indented (not deeper than 1/64 in.) into the exposed surface of the gypsum board.

7. **Finishing System - (Not Shown)** — Vinyl, dry or premixed joint compound, applied in two coats to joints and screw-heads. Nom 2 in. wide paper tape embedded in first layer of compound over all joints. As an alternate, nom 3/32 in. thick veneer plaster may be applied to the entire surface of gypsum board.

*** Indicates such products shall bear the UL or cUL Certification Mark for jurisdictions employing the UL or cUL Certification (such as Canada), respectively.**

Last Updated on 2023-04-04