

Design No. **L502**
 April 04, 2023

Unrestrained Assembly Rating — 1 Hr
Finish Rating — 22 Min. or (16 Min. See Item 7D)

This design was evaluated using a load design method other than the Limit States Design Method (e.g., Working Stress Design Method). For jurisdictions employing the Limit States Design Method, such as Canada, a load restriction factor shall be used — See Guide [BXUV](#) or [BXUV7](#)

* Indicates such products shall bear the UL or cUL Certification Mark for jurisdictions employing the UL or cUL Certification (such as Canada), respectively.

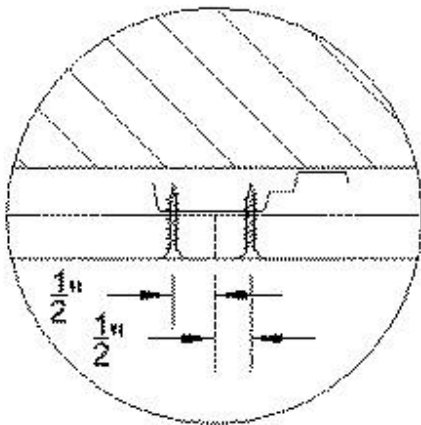
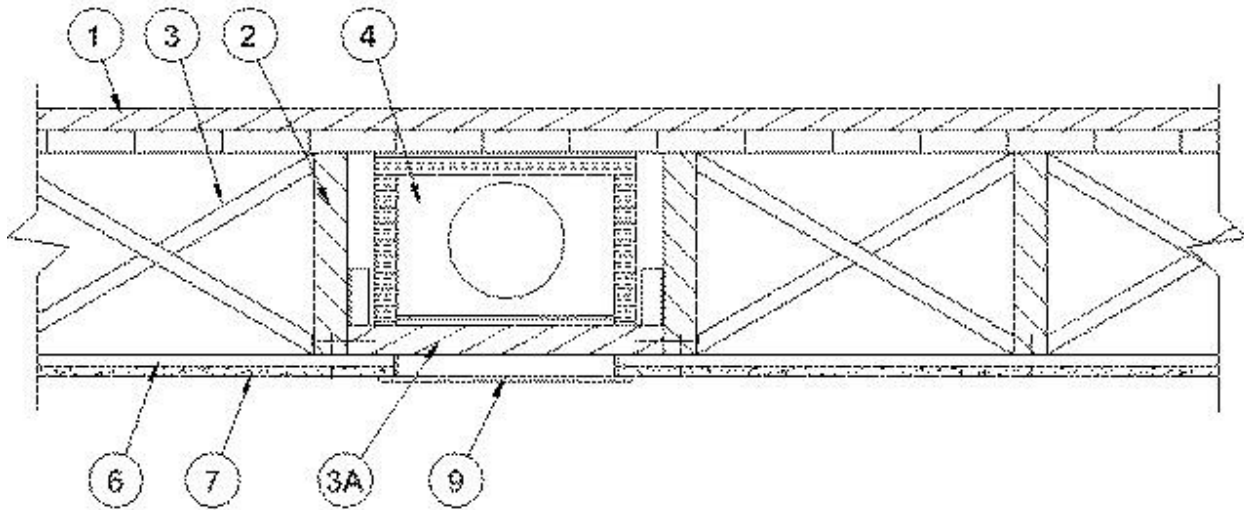

End Joint

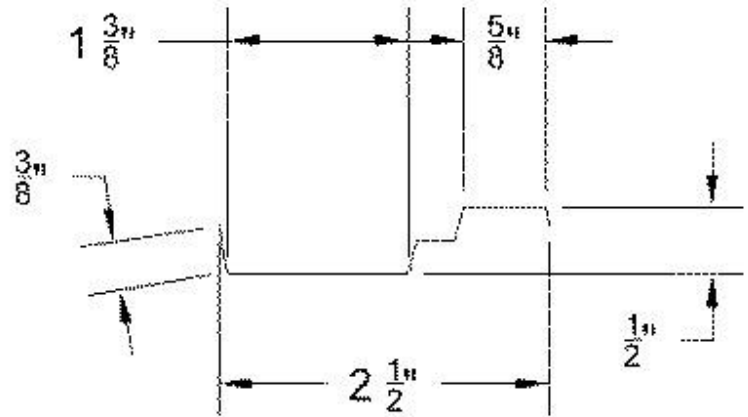

Resilient Channel Detail

- 1. Finish Flooring** — The flooring system shall consist of one of the following:
System No. 1

Subflooring — Min 1 by 6 in. T & G lumber fastened diagonally to joists, or min 15/32 in. thick wood structural panels, min grade "C-D" or "Sheathing". Face grain of plywood or strength axis of panels to be perpendicular to the joists with joints staggered.

Vapor Barrier — (Optional) — Nom 0.010 in. thick commercial rosin-sized building paper.

Finish Flooring — Min 1 by 4 in. T & G lumber fastened diagonally to joists, or min 19/32 in. wood structural panels, min grade "Underlayment" or "Single Floor". Face grain of plywood or strength axis of panels to be perpendicular to joists with joints staggered.

System No. 2

Subflooring — Min 1 by 6 in. T & G lumber fastened diagonally to joists, or min 15/32 in. thick wood structural panels, min grade "C-D" or "Sheathing". Face grain of plywood or strength axis of panels to be perpendicular to the joists with joints staggered.

Vapor Barrier — (Optional) — Nom 0.010 in. thick commercial rosin-sized building paper.

Finish Flooring — Floor Topping Mixture* — Min 1-1/2 in. thickness of floor topping mixture having a min compressive strength of 1000 psi and a cast density of 100 plus or minus 5 pcf. Foam concentrate mixed 40:1 by volume with water and expanded at 100 psi through nozzle. Mixture shall consist of 1.4 cu feet of preformed foam concentrate to 94 lbs Type I Portland cement, 300 lbs of sand with 5-1/2 gal of water.

ELASTIZELL CORP OF AMERICA — Type FF

System No. 3

Subflooring — Min 1 by 6 in. T & G lumber fastened diagonally to joists, or min 15/32 in. thick wood structural panels, min grade "C-D" or "Sheathing". Face grain of plywood or strength axis of panels to be perpendicular to the joists with joints staggered.

Vapor Barrier — (Optional) — Nom 0.010 in. thick commercial rosin-sized building paper.

Floor Mat Materials* — (Optional) — Floor mat material nom 5/64 in. (2 mm) thick adhered to subfloor with Hacker Floor Primer. Primer to be applied to the surface of the mat prior to the placement of a min 1-1/4 in. of floor-topping mixture.

HACKER INDUSTRIES INC — Type Hacker Sound-Mat

Alternate Floor Mat Materials — (Optional) — Floor mat material nom 1/4 in. (6 mm) thick adhered to subfloor with Hacker Floor Primer. Primer to be applied to the surface of the mat prior to the placement of a min 1-1/4 in. (32 mm) of floor-topping mixture.

HACKER INDUSTRIES INC — Type Hacker Sound-Mat II

Alternate Floor Mat Materials — (Optional) — Floor mat material nom 1/8 in. (3 mm) thick loose laid over the subfloor. Floor topping thickness shall be a min of 1 in. (25 mm)

HACKER INDUSTRIES INC — Type FIRM-FILL SCM 125

Alternate Floor Mat Materials — (Optional) — Floor mat material nom 1/4 in. (6 mm) thick loose laid over the subfloor. Floor topping thickness shall be a min of 1 in. (25 mm)

HACKER INDUSTRIES INC — Type FIRM-FILL SCM 250, Quiet Qurl 55/025

Alternate Floor Mat Materials — (Optional) — Floor mat material nom 3/8 in. (10 mm) thick loose laid over the subfloor. Floor topping thickness shall be a min of 1-1/4 in. (32 mm)

HACKER INDUSTRIES INC — Types FIRM-FILL SCM 400, Quiet Qurl 60/040

Alternate Floor Mat Materials — (Optional) — Floor mat material nom 3/4 in. (19 mm) thick loose laid over the subfloor. Floor topping thickness shall be a min of 1-1/2 in. (38 mm)

HACKER INDUSTRIES INC — Types FIRM-FILL SCM 750, Quiet Qurl 65/075

Metal Lath (Optional) — For use with 3/8 in. (10 mm) floor mat materials, 3/8 in. expanded steel diamond mesh, 3.4 lbs/sq yd placed over the floor mat material. Hacker Floor Primer to be applied prior to the placement of the metal lath. When metal lath is used, floor topping thickness a nom 1-1/4 in. over the floor mat.

Finish Flooring — Floor Topping Mixture* — Min 1 in. thickness of floor topping mixture having a min compressive strength of 1100 psi. Mixture shall consist of 6.8 gal of water to 80 lbs of floor topping mixture to 1.9 cu ft of sand.

HACKER INDUSTRIES INC — Firm-Fill Gypsum Concrete, Firm-Fill 2010, Firm-Fill 3310, Firm-Fill 4010, Firm-Fill High Strength, Gyp-Span Radiant

System No. 4

Deleted.

System No. 5

Subflooring — Min 1 by 6 in. T & G lumber fastened diagonally to joists, or min 15/32 in. thick wood structural panels, min grade "C-D" or "Sheathing". Face grain of plywood or strength axis of panels to be perpendicular to the joists with joints staggered.

Vapor Barrier — (Optional) — Nom 0.010 in. thick commercial rosin-sized building paper.

Finish Flooring — Floor Topping Mixture* — Min 1-1/2 in. thickness of floor topping mixture having a min compressive strength of 1000 psi and a cast density of 100 plus or minus 5 pcf. Foam concentrate mixed 40:1 by volume with water and expanded at 100 psi through nozzle. Mixture shall

consist of 1.2 cu feet of preformed foam concentrate to 94 lbs Type I Portland cement, 300 lbs of sand with 5.5 gal of water.

AERIX INDUSTRIES — Floor-Topping Mixture

System No. 6

Subflooring — Min 1 by 6 in. T & G lumber fastened diagonally to joists, or min 15/32 in. thick wood structural panels, min grade "C-D" or "Sheathing". Face grain of plywood or strength axis of panels to be perpendicular to the joists with joints staggered.

Vapor Barrier — (Optional) — Nom 0.010 in. thick commercial rosin-sized building paper.

Finish Flooring — Floor Topping Mixture* — Min 1 in. thickness of floor topping mixture having a min compressive strength of 1000 psi. Mixture shall consist of 5 to 8 gal of water to 80 lbs of floor topping mixture to 2.1 cu ft of sand.

ULTRA QUIET FLOORS — Types UQF-A, UQF-Super Blend, UQF-Plus 200

System No. 7

Subflooring — Min 1 by 6 in. T & G lumber fastened diagonally to joists, or min 15/32 in. thick wood structural panels, min grade "C-D" or "Sheathing". Face grain of plywood or strength axis of panels to be perpendicular to the joists with joints staggered.

Vapor Barrier — (Optional) — Nom 0.010 in. thick commercial rosin-sized building paper.

Finish Flooring - Floor Topping Mixture* — Min 3/4 in. thickness of floor topping mixture having a minimum compressive strength of 1500 psi. Refer to manufacturer's instructions accompanying the material for specific mix design.

MAXXON CORP — Types Maxxon Standard and Maxxon High Strength

Floor Mat Materials* — (Optional) — Floor mat material loose laid over the subfloor. Refer to manufacturer's instructions regarding the minimum thickness of floor topping over each floor mat material.

MAXXON CORP — Type Encapsulated Sound Mat.

Floor Mat Reinforcement — (Optional) - Refer to manufacturer's instructions regarding minimum thickness of floor topping for use with floor mat reinforcement.

Metal Lath — (Optional) — 3/8 in. expanded galvanized steel diamond mesh, 3.4 lbs/sq yd loose laid over the floor mat material.

Fiber Glass Reinforcement - (Optional, Not Shown) - 0.015 in. thick PVC coated non-woven fiberglass mesh, 0.368 lbs/sq yd loose laid over the floor mat material.

System No. 8

Subflooring — Min 1 by 6 in. T & G lumber fastened diagonally to joists, or min 15/32 in. thick wood structural panels, min grade "C-D" or "Sheathing". Face grain of plywood or strength axis of panels to be perpendicular to the joists with joints staggered.

Vapor Barrier — (Optional) — Nom 0.010 in. thick commercial rosin-sized building paper.

Finish Flooring — Floor Topping Mixture* — Min 3/4 in. thickness of floor topping mixture having a min compressive strength of 1000 psi. Refer to manufacturer's instructions accompanying the material for specific mix design.

FORMULATED MATERIALS LLC — Types FR-25, FR-30, and SiteMix.

Alternate Floor Mat Material* — (Optional) — Floor mat material nominal 2 - 9.5 mm thick loose laid over the subfloor. Floor topping shall be a min of 1 in.

FORMULATED MATERIALS LLC — Types M1, M2, M3, Elite, Duo, R1, and R2.

System No. 9

Subflooring — Min 1 by 6 in. T & G lumber fastened diagonally to joists, or min 15/32 in. thick wood structural panels, min grade "C-D" or "Sheathing". Face grain of plywood or strength axis of panels to be perpendicular to the joists with joints staggered.

Vapor Barrier — (Optional) — Nom 0.010 in. thick commercial rosin-sized building paper.

Finish Floor — Mineral and Fiber Board* — Min 1/2 in. thick, supplied in sizes ranging from 3 ft by 4 ft to 8 ft by 12 ft. All joints to be staggered a min of 12 in. with adjacent sub-floor joints.

HOMASOTE CO — Type 440-32 Mineral and Fiber Board

System No. 10

Subflooring — Min 1 by 6 in. T & G lumber fastened diagonally to joists, or min 15/32 in. thick wood structural panels, min grade "C-D" or "Sheathing". Face grain of plywood or strength axis of panels to be perpendicular to the joists with joints staggered.

Vapor Barrier — (Optional) — Nom 0.010 in. thick commercial rosin-sized building paper.

Finish Flooring — Floor Topping Mixture* — Min 3/4 in. thickness of floor topping mixture having a minimum compressive strength of 1800 psi. Refer to manufacturer's instructions accompanying the material for specific mix design.

UNITED STATES GYPSUM CO — Types LRK, HSLRK, CSD

USG MEXICO S A DE C V — Types LRK, HSLRK, CSD

Floor Mat Materials* — (Optional) — Floor mat material loose laid over the subfloor. Refer to manufacturer's instructions regarding the minimum thickness of floor topping over each floor mat material.

UNITED STATES GYPSUM CO — Types SAM, LEVELROCK® Brand Sound Reduction Board, LEVELROCK® Brand Floor Underlayment SRM-25

Alternate Floor Mat Materials* — (Optional) — Floor mat material loose laid over the subfloor. Refer to manufacturer's instructions regarding minimum thickness of floor topping over floor mat.

GRASSWORX L L C — SC Types

Alternate Floor Mat Material* — (Optional) — Floor mat material nominal 3/8 in. thick loose laid over the subfloor. Floor topping shall be a min 1 in. thick.

System No. 11

Subflooring — Min 1 by 6 in. T & G lumber fastened diagonally to joists, or min 15/32 in. thick wood structural panels, min grade "C-D" or "Sheathing". Face grain of plywood or strength axis of panels to be perpendicular to the joists with joints staggered.

Vapor Barrier — (Optional) — Nom 0.010 in. thick commercial rosin-sized building paper.

Finish Flooring — Floor Topping Mixture* — Min 3/4 in. thickness of floor topping mixture having a min compressive strength of 1000 psi. Refer to manufacturer's instructions accompanying the material for specific mix design.

ARCOSA SPECIALTY MATERIALS — AccuCrete® Types NexGen, Green, Prime and PrePour, AccuRadiant®, AccuLevel® Types G40, G50 and SD30

Alternate Floor Mat Material* - (Optional) - Floor mat material nominal 5/64 in. - 16/64 in. thick loose laid over the subfloor. Floor topping shall be a min of 3/4 in.

ARCOSA SPECIALTY MATERIALS— AccuQuiet® Types D13, D-18, D25, EM.125, EM.125S, EM.250, EM.250S.

Alternate Floor Mat Material* - (Optional) — Floor mat material nominal 2 - 9.5 mm thick loose laid over the subfloor. Floor topping shall be a min of 1 in.

ARCOSA SPECIALTY MATERIALS — AccuQuiet Types D25, DX38, EM.250, EM.250S, EM.375, EM.375S, EM.750, and EM.750S.

System No. 12

Subflooring — 15/32 or 19/32 in. thick wood structural panels, min. grade "C-D" or "Sheathing". Face grain of plywood or strength axis of panels to be perpendicular to joists with joints staggered.

Vapor Barrier — (Optional) — Nom 0.030 in. thick commercial asphalt saturated felt.

Finish Flooring — Floor Topping Mixture* — Min 3/4 or 1 in. thickness of floor topping mixture for 19/32 or 15/32 in. thick wood structural panels respectively, having a min compressive strength of 2100 psi. Refer to manufacturer's instructions accompanying the material for specific mix design. Refer to the manufacturer's instructions accompanying the material and/or contact the manufacturer's technical support for specific mix design and minimum thickness recommended for use with eligible floor mat(s).

System No. 13

Subflooring — Min 15/32 in. thick wood structural panels, min grade "C-D" or "Sheathing". Face grain of plywood or strength axis of panels to be perpendicular to the joists with joints staggered.

Vapor Barrier — (Optional) — Commercial asphalt saturated felt, 0.030 in. thick.

Vapor Barrier — (Optional) — Nom 0.010 in. thick commercial rosin-sized building paper.

Finish Flooring* — Min 3/4 in. thickness of any Floor Topping Mixture bearing the UL Classification Marking as to Fire Resistance. See Floor- and Roof-Topping Mixtures (CCOX) category for names of Classified Companies. Refer to the manufacturer's instructions accompanying the material and/or contact the manufacturer's technical support for specific mix design and minimum thickness recommended for use with eligible floor mat(s).

Floor Mat Materials* — (Optional) — Nom. 1/4 in. thick loose laid over the subfloor. Floor topping thickness shall be a minimum of 3/4 in.

KEENE BUILDING PRODUCTS CO INC — Type Quiet Qurl 55/025 and Quiet Qurl 55/025 N

Alternate Floor Mat Materials* — (Optional) - Floor mat material Nom. 3/8 in. thick loose laid over the subfloor. Floor topping thickness shall be a minimum of 1 in.

KEENE BUILDING PRODUCTS CO INC — Type Quiet Qurl 60/040 and Quiet Qurl 60/040 N

Alternate Floor Mat Materials* — (Optional) — Floor mat material Nom. 3/4 in. thick loose laid over the subfloor. Floor topping thickness shall be a minimum of 1-1/2 in.

KEENE BUILDING PRODUCTS CO INC — Type Quiet Qurl 65/075, Quiet Qurl 65/075 N

Alternate Floor Mat Materials* — (Optional) — Floor mat material Nom. 1/8 in. thick loose laid over the subfloor. Floor topping thickness shall be a minimum of 3/4 in.

KEENE BUILDING PRODUCTS CO INC — Type Quiet Qurl 52/013 and Quiet Qurl 52/013 N

Alternate Floor Mat Materials* — (Optional) — Floor mat material Nom. 1/4 in. entangled net core with a compressible fabric attached to the bottom loose laid over the subfloor. Floor topping thickness shall be a minimum of 1 in.

KEENE BUILDING PRODUCTS CO INC — Quiet Qurl 55/025 MT and Quiet Qurl 55/025 N MT

System No. 14

Subflooring — Min 23/32 in. thick T&G wood structural panels, min grade "Underlayment" or "Single-Floor". Face grain of plywood or strength axis of panels to be perpendicular to the joists with end joints staggered 4 ft. Panels secured to joists with construction adhesive and No. 6d ringed shank nails spaced 12 in. OC along each joist. Staples having equal or greater withdrawal and lateral resistance strength may be substituted for the 6d nails.

Gypsum Board* — One layer of nom 5/8 in. thick, 4 ft wide gypsum board, installed with long dimension perpendicular to joists. Gypsum board secured with 1 in. long No. 6 Type W bugle head steel screws spaced 12 in. OC and located a min of 1-1/2 in. from side and end joints. The joints of the gypsum board are to be staggered a minimum of 12 inches from the joints of the subfloor.

GEORGIA-PACIFIC GYPSUM L L C — Type DS

Floor Mat Materials* — (As an alternate to the single layer gypsum board) — Floor mat material loose laid over the subfloor.

MAXXON CORP — Type Encapsulated Sound Mat

Gypsum Board* — (For use when floor mat is used) Two layers of nom 5/8 in. thick, 4 ft wide gypsum board, installed with long dimension perpendicular to joists on top of the floor mat material. Gypsum board secured to each other with 1 in. long No. 6 Type G bugle head steel screws spaced 12 in. OC and located a min of 1-1/2 in. from side and end joints. The joints of the gypsum board are to be staggered a minimum of 12 inches in between layers and from the joints of the subfloor.

GEORGIA-PACIFIC GYPSUM L L C — Type DS

System No. 15

Subflooring — Min 1 by 6 in. T & G lumber fastened diagonally to joists, or min 15/32 in. thick wood structural panels, min grade "C-D" or "Sheathing". Face grain of plywood or strength axis of panels to be perpendicular to the joists with joints staggered.

Vapor Barrier — (Optional) — Nom 0.010 in. thick commercial rosin-sized building paper.

Finish Flooring — Floor Topping Mixture* — Min 3/4 in. thickness of floor topping mixture having a min compressive strength of 1000 psi. Refer to manufacturer's instructions accompanying the material for specific mix design.

DEPENDABLE LLC — GSL M3.4, GSL K2.6, GSL-CSD and GSL RH

Floor Mat Materials*— (Optional) — Nom. 1/4 in. thick loose laid over the subfloor. Floor topping thickness shall be a minimum of 3/4 in.

KEENE BUILDING PRODUCTS CO INC — Type Quiet Qurl 55/025 and Quiet Qurl 55/025 N

Alternate Floor Mat Materials* — (Optional) — Floor mat material Nom. 3/8 in. thick loose laid over the subfloor. Floor topping thickness shall be a minimum of 1 in.

KEENE BUILDING PRODUCTS CO INC — Type Quiet Qurl 60/040 and Quiet Qurl 60/040 N

Alternate Floor Mat Materials* — (Optional) — Floor mat material Nom. 3/4 in. thick loose laid over the subfloor. Floor topping thickness shall be a minimum of 1-1/2 in.

KEENE BUILDING PRODUCTS CO INC — Type Quiet Qurl 65/075, Quiet Qurl 65/075 N

Alternate Floor Mat Materials* — (Optional) — Floor mat material Nom. 1/8 in. thick loose laid over the subfloor. Floor topping thickness shall be a minimum of 3/4 in.

KEENE BUILDING PRODUCTS CO INC — Type Quiet Qurl 52/013 and Quiet Qurl 52/013 N

Alternate Floor Mat Materials* — (Optional) — Floor mat material Nom. 1/4 in. entangled net core with a compressible fabric attached to the bottom loose laid over the subfloor. Floor topping thickness shall be a minimum of 1 in.

KEENE BUILDING PRODUCTS CO INC — Quiet Qurl 55/025 MT and Quiet Qurl 55/025 N MT

System No. 16

Subflooring — Min 15/32 in. thick wood structural panels, min grade "C-D" or "Sheathing". Face grain of plywood or strength axis of panels to be perpendicular to the joists with joints staggered.

Vapor Barrier — (Optional) — Commercial asphalt saturated felt, 0.030 in. thick.

Vapor Barrier — (Optional) — Nom 0.010 in. thick commercial rosin-sized building paper.

Finish Flooring* — Min 3/4 in. thickness of any Floor Topping Mixture bearing the UL Classification Marking as to Fire Resistance. See Floor- and Roof-Topping Mixtures (CCOX) category for names of Classified Companies. Refer to the manufacturer's instructions accompanying the material and/or contact the manufacturer's technical support for specific mix design and minimum thickness recommended for use with eligible floor mat(s).

Floor Mat Materials* — (Optional) — Nom 3/32 in. thick loose laid over the subfloor. Floor topping thickness shall be a minimum of 3/4 in.

PLITEQ INC — Type GenieMat RST02

Floor Mat Materials* — (Optional) — Nom 3/16 in. thick loose laid over the subfloor. Floor topping thickness shall be a minimum of 3/4 in.

PLITEQ INC — Type GenieMat FF03NP

Floor Mat Materials* — (Optional) — Nom 1/4 in. thick loose laid over the subfloor. Floor topping thickness shall be a minimum of 3/4 in.

PLITEQ INC — Type GenieMat FF06

Floor Mat Materials* — (Optional) — Nom 3/8 in. thick loose laid over the subfloor. Floor topping thickness shall be a minimum of 1 in.

PLITEQ INC — Type GenieMat FF10

Floor Mat Materials* — (Optional) — Nom 3/4 in. thick loose laid over the subfloor. Floor topping thickness shall be a minimum of 1-1/2 in.

PLITEQ INC — Type GenieMat FF17

Floor Mat Materials* — (Optional) — Nom 1 in. thick loose laid over the subfloor. Floor topping thickness shall be a minimum of 1-1/2 in.

PLITEQ INC — Type GenieMat FF25

System No. 17

Subflooring — Building Units* — Nom 3/4 in. thick, tongue and grooved boards. Long dimension of boards to be perpendicular to joists with end joints staggered a min of 4 ft. and centered over the joists. Boards secured to joists with 2 in. long self-drilling, self-tapping screws or 2 in. x 0.113 in. Ring

Shank nails spaced a max of 12 in. OC in the field with screws/nails located 1 in. from long edge, and max 8 in. OC along the end joints with screws/nails located 1/2 in. from end joint.

ECTEK INTERNATIONAL INC — Type MegaBoard

Vapor Barrier (Optional) — Nom 0.010 in. thick commercial rosin-sized building paper.

Finish Flooring — Min 1 by 4 in. T & G lumber fastened diagonally to joists, or min 19/32 in. wood structural panels, min grade "Underlayment" or "Single Floor". Face grain of plywood or strength axis of panels to be perpendicular to joists with joints staggered.

Finish Flooring is optional when the alternate subfloor Type MegaBoard is used.

System No. 18

Subflooring — Min 1 by 6 in. T & G lumber fastened diagonally to joists, or min 15/32 in. thick wood structural panels, min grade "C-D" or "Sheathing". Face grain of plywood or strength axis of panels to be perpendicular to the joists with joints staggered.

Finish Flooring* — Floor Topping Materials — Min 3/4 in. to 1-1/2 in. thickness of any Floor Topping Mixture bearing the UL Classification Marking as to Fire Resistance with a minimum compressive strength of 1500 psi.

See **Floor- and Roof-Topping Mixtures** (CCOX) category for names of Classified Companies. Refer to the manufacturer's instructions accompanying the material and/or contact the manufacturer's technical support for specific mix design and minimum thickness recommended for use with eligible floor mat(s).

Floor Mat Materials* — (Optional) — Floor mat material nom 1/8 in. to 3/4 in. thick. Loose laid over the subfloor. When used, Acousti-flor CSM (crack suppression mat) is loose laid over the floor mat material. Floor topping material thickness is dependent on thickness of floor mat used.

WALFLOR INDUSTRIES INC — Type Acousti-flor, Acousti-flor CSM. Floor topping thickness depends on products used as follows:

Acousti-flor (1/8 in. thick) - Floor topping thickness shall be a minimum of 3/4 in.

Acousti-flor (1/4 in. thick) - Floor topping thickness shall be a minimum of 1 in.

Acousti-flor (3/8 in. thick) - Floor topping thickness shall be a minimum of 1 in.

Acousti-flor (3/4 in. thick) - Floor topping thickness shall be a minimum of 1-1/2 in.

Metal Lath — (Optional) — Expanded steel diamond mesh, 2.5 lb / sq yd loose laid over floor mat material.

Fiberglass Mesh Reinforcement — (Optional) — Coated non-woven glass fiber mesh grid loose laid over floor mat material.

System No. 19

Subflooring — Min 15/32 in. thick wood structural panels, min grade "C-D" or "sheathing." Face grain of plywood or strength axis of panels to be perpendicular to the joist with joints staggered.

Wall and Partition Facings and Accessories* - Sound Barrier (Optional) — Acoustic Sleeper pads stapled to the top of the subfloor, the bottom of the finish floor, or to 5/16 in. thick by 1-1/2 in. wide

wood strips and centered over wood joist. Acoustic Sleeper pads are to be spaced appropriately so that the finish floor panels are fastened through Acoustic Sleeper pads to the joist.

STC ARCHITECTURAL PRODUCTS L L C DBA STC SOUND CONTROL — Acoustic Sleeper

Finish Floor — Min 19/32 in. wood structural panels min grade "Underlayment" or "Single Floor". Face grain of plywood or strength axis of panels to be perpendicular to joists with joints staggered and panels fastened through to joist. Butt joints of panels have the option of being sealed with any UL Classified caulk or sealant found under - Fill, Void or Cavity Materials* (XHHW).

System No. 20

Subflooring — Min 23/32 in. thick wood structural panels, min grade "C-D" or "Sheathing". Face grain of plywood or strength axis of panels to be perpendicular to the joists with joints staggered.

Vapor Barrier — (Optional) — Commercial asphalt saturated felt, 0.030 in. thick.

Vapor Barrier — (Optional) — Nom 0.010 in. thick commercial rosin-sized building paper.

Finish Flooring — Floor Topping Mixture* — Min 3/4 in. thickness of floor topping mixture having a min compressive strength of 1000 psi. Refer to manufacturer's instructions accompanying the material for specific mix design.

ARCOSA SPECIALTY MATERIALS — AccuCrete® Types NexGen, Green, Prime, and PrePour, AccuRadiant®, AccuLevel® Types G40, G50 and SD30.

Alternate Floor Mat Material* — (Optional) - Floor mat material nominal 5/64 in. - 16/64 in. thick loose laid over the subfloor. Floor topping shall be a min of 3/4 in.

ARCOSA SPECIALTY MATERIALS — AccuQuiet® Types D-18, D25, EM.125, EM.125S, EM.250, EM.250S.

Alternate Floor Mat Material* — (Optional) - Floor mat material nominal 17/64 - 48/64 in. thick loose laid over the subfloor. Floor topping shall be a min of 1 in.

ARCOSA SPECIALTY MATERIALS — AccuQuiet® Types DX38, EM.375, EM.375S, EM.750, and EM.750S.

System No. 21

Subflooring — Min 1 by 6 in. T & G lumber fastened diagonally to joists, or min 15/32 in. thick wood structural panels, min grade "C-D" or "Sheathing". Face grain of plywood or strength axis of panels to be perpendicular to the joists with joints staggered.

Finish Flooring - Floor Topping Mixture* — Min 1 in. thickness of floor topping mixture having a min compressive strength of 4500 psi. Refer to manufacturer's instructions accompanying the material for specific mix design.

SIKA DEUTSCHLAND GMBH — Type SCHONOX AP Rapid Plus

System No. 22

Subflooring — Min 1 by 6 in. T & G lumber fastened diagonally to joists, or min 15/32 in. thick wood structural panels, min grade "C-D" or "Sheathing". Face grain of plywood or strength axis of panels to be perpendicular to the joists with joints staggered.

Vapor Barrier — (Optional) - Commercial asphalt saturated felt, 0.030 in. thick.

Vapor Barrier — (Optional) - Nom 0.010 in. thick commercial rosin-sized building paper.

Finish Flooring - Floor Topping Mixture* — Min 3/4 in. thickness of any Floor Topping Mixture bearing the UL Classification Marking as to Fire Resistance. See Floor- and Roof-Topping Mixtures (CCOX) category for names of Classified Companies. Refer to the manufacturer's instructions accompanying the material and/or contact the manufacturer's technical support for specific mix design and minimum thickness recommended for use with eligible floor mat(s).

Floor Mat Materials* — (Optional, Not Shown) - Floor mat material loose laid over the subfloor. Refer to manufacturer's instructions regarding the minimum thickness of floor topping over each floor mat material.

LOW & BONAR INC — EnkaSonic® by Colbond a member of the Low & Bonar group Types 125, 250, 250 Plus, 400, 400 Plus, 750, and 750 Plus.

Floor Mat Reinforcement — (Optional) - Refer to manufacturer's instructions regarding minimum thickness of floor topping for use with floor mat reinforcement.

Metal Lath — (Optional) — Expanded steel diamond mesh, 2.5 lb / sq yd loose laid over floor mat material.

Fiberglass Mesh Reinforcement — (Optional) — Coated non-woven glass fiber mesh grid loose laid over floor mat material.

System No. 23

Subflooring — Min 15/32 in. thick wood structural panels, min grade "C-D" or "Sheathing". Face grain of plywood or strength axis of panels to be perpendicular to the joists with joints staggered.

Vapor Barrier — (Optional) — Nom 0.030 in. thick commercial asphalt saturated felt.

Floor Mat Materials* — (Optional) — Floor mat material loose laid over the subfloor. Refer to manufacturer's instructions regarding the minimum thickness of floor topping over each floor mat material.

GRASSWORX L L C — SC Types

Finish Flooring* — Min 3/4 in. thickness of any Floor Topping Mixture bearing the UL Classification Marking as to Fire Resistance. See Floor- and Roof-Topping Mixtures (CCOX) category for names of Classified Companies. Refer to the manufacturer's instructions accompanying the material and/or contact the manufacturer's technical support for specific mix design and minimum thickness recommended for use with eligible floor mat(s).

Floor Mat Reinforcement — (Optional) - Refer to manufacturer's instructions regarding minimum thickness of floor topping for use with floor mat reinforcement.

Metal Lath — (Optional) — Expanded steel diamond mesh, 2.5 lb / sq yd loose laid over floor mat material.

Fiberglass Mesh Reinforcement — (Optional) — Coated non-woven glass fiber mesh grid loose laid over floor mat material.

System No. 24

Subflooring — Subflooring — Nom 23/32 in. thick wood structural panels installed perpendicular to trusses with end joints staggered. Wood structural panels secured to trusses with construction adhesive and No. 6d ringed shank nails, spaced 12 in. OC along each truss. Staples having equal or greater withdrawal and lateral resistance strength may be substituted for the 6d nails. Screws may be substituted for nails, one for one, when the head diameter, length, and spacing equal or exceed the requirements for the specified nails.

Finish Floor - Building Units* — Min 1/2 in. thick magnesium oxide panels installed parallel, perpendicular, or diagonally to trusses with panel edges offset a min of 4 in. between subfloor and magnesium oxide panels. Panels secured to subfloor with construction adhesive and corrosion resistant fasteners, spaced max 12 in. OC around the perimeter and in the field of the panel. Fasteners must be placed no closer than 1/2 in. from all panel edges and no closer than 2 in. from panel corners. Screws may be substituted for nails, one for one, when the head diameter, length, and spacing equal or exceed the requirements for the specified nails.

HUBER ENGINEERED WOODS L L C — Type 1/2 in. Square Edge Exacor™ Board

System No. 25

Building Units* — Nom 3/4 in. thick. Long dimension of panels to be perpendicular to trusses with end joints staggered a min of 4 ft. and joints centered over the joists. Panels secured to wood joists with 2 in. x 0.113 in. Ring Shank nails spaced a max of 12 in. OC in the field and on the perimeter. Fasteners must be placed no closer than 1/2 in. from all panel edges and no closer than 2 in. from panel corners. Screws may be substituted for nails, one for one, when the head diameter, length, and spacing equal or exceed the requirements for the specified nails. When used, **Batts and Blankets***, Item 5C are required and Gypsum Wallboard* thickness increased to 5/8 in. with gypsum board fasteners increased in length by 1/8 in. from that specified for 1/2 in. thick gypsum board.

HUBER ENGINEERED WOODS L L C — Type 3/4 in. Tongue and Groove Exacor™ Board

2. **Wood Joists** — Min 2 by 10, spaced 16 in. OC and effectively fireblocked in accordance with local codes.

3. **Cross Bridging** — Min 1 by 3 in. or min 2 by 10 solid blocking.

3A. **Horizontal Bridging** — Used in lieu of Item 3 in same joist bay as ceiling damper (Item 4), when ceiling damper is employed. Wood 2 by 4 in. secured between joists with nails.

4. **Ceiling Damper*** — **(Optional)** — Max nom area shall be 198 sq in. Max rectangular size shall be 12 in. wide by 16-1/2 in. long. Max height of damper shall be 8-3/4 in. Aggregate damper openings shall not exceed 99 sq in. per 100 sq ft of ceiling area. Damper installed in accordance with the manufacturers installation instructions provided with the damper. A steel grille (Item 9) shall be installed in accordance with installation instructions.

AIR BALANCE INC — Type 299 (See Item 7D)

AIR KING VENTILATION PRODUCTS — Series FRAS, Series FRAK, Series FRAKV

CENTRAL VENTILATION SYSTEMS CO L L C — Models C-S/R-HC(-A), C-RD-HC(-A); Models CD-S/R-HC, CD-RD-HC

GREENHECK FAN CORP — Model CRD-1WJ

METAL-FAB INC — Models MSCDHC, MRCDHC

METAL INDUSTRIES INC — Models CD-S/R-HC, CD-S/R-HC-A, CD-RD-HC, CD-RD-HC-A

NCA MFG INC — Models CD-S/R-HC, CD-S/R-HC-A, CD-RD-HC, CD-RD-HC-A

BRISK MFG INC — Model BMI-50-CRD-S/R-WT

PRICE INDUSTRIES LTD

RUSKIN COMPANY — Model CFD7

UNITED ENERTECH CORP — Models C-S/R-HC(-A), C-RD-HC(-A)

5. **Batts and Blankets*** — **(Optional, Not Shown)** — For use with **Steel Framing Members*** (Items 6C and 6G only) and **Gypsum Board*** (Items 7A and 7B). Any thickness mineral wool or glass fiber insulation bearing the UL Classification Marking for Surface Burning Characteristics, having a flame spread index of 25 or less and a smoke developed index of 50 or less. Insulation fitted in the concealed space, draped over the steel framing members/gypsum board ceiling membrane.

5A. **Batts and Blankets*** — For use with Items 6G and 7C only - Glass fiber insulation draped over the resilient channel/gypsum panel ceiling membrane. Max. 3-1/2 in. thickness of glass fiber insulation bearing the UL Classification Marking as to Surface Burning Characteristics and/or Fire Resistance having a min. density of 0.5 pcf.

5B. **Batts and Blankets*** — For use with **Steel Framing Members*** (Item 6K) and **Gypsum Board*** (Item 7E) - Min. 3-1/2 in. thick, min. density 0.9 lb/ft³ unfaced fiberglass batt insulation bearing the UL Classification Marking for Surface Burning Characteristics, having a flame spread

value of 25 or less and a smoke spread value of 50 or less. Insulation fitted in the concealed space, draped over steel framing members/gypsum board ceiling membrane and light fixture protection.

5C. **Batts and Blankets*** — Specified for use with **System No. 25**. 3-1/2 in. thick, min 0.62 pcf glass fiber batt insulation draped over the resilient channels. Any glass fiber batt insulation bearing the UL Classification Marking for Surface Burning Characteristics or fire Resistance may be used. See **Batts and Blankets* (BKNV or BZJZ)** category in the Fire Resistance Directory for names of manufacturers.

6. **Resilient Channels** — Resilient channels, formed from No. 25 MSG galv steel and shaped as shown, spaced 24 in. OC perpendicular to joist. Channels overlapped 4 in. at splices and secured to each joist with one 6d common nail. Min end clearance of channels to wall to be 1/2 in. Additional resilient channels positioned so as to coincide with end joints of gypsum board (Item 7). Additional channels shall extend min 6 in. beyond each side edge of board.

6A. **Steel Framing Members* — (Not Shown)** — As an alternate to Item 6, main runners nom 12 ft long spaced 48 in. OC. Cross tees nom 4 ft long installed perpendicular to main runners and spaced 16 in. OC. Additional cross tees located 8 in. from and on each side of gypsum board end joints. Main runners suspended by min 12 SWG galv steel hanger wires spaced 48 in. OC. Hanger wires to be located adjacent to main runner/cross tee intersections. Hanger wires wrapped and twist-tied on 16d nails driven into the side of joists at least 5 in. above the joist bottom face.

ROXUL USA INC. D/B/A ROCKFON — Types 650, 650C, 670, 670C

6B. **Steel Framing Members* — (Not Shown)** — As an alternate to Item 6, main runners nom 12 ft long, spaced 48 in. OC. Ends of main runners at walls to rest on wall angle, without attachment, with 1/2 to 3/4 in. end clearance. Primary cross tees (1-1/2 in. wide across flange) or cross channels, nom 4 ft long, installed perpendicular to main runners and spaced 24 in. OC. Additional primary cross tees or cross channels required at each gypsum board end joint and 8 in. from and on each side of gypsum board end joint.

ARMSTRONG WORLD INDUSTRIES INC — Type DFR-8000

6C. **Steel Framing Members* — (Not Shown)** — As an alternate to Item 6, main runners, cross tees, cross channels and wall angle as listed below:

a. **Main Runners** — Nom 10 or 12 ft long, 15/16 in. or 1-1/2 in. wide face, spaced 4 ft OC. Main runners suspended by min 12 SWG galv steel hanger wires spaced 48 in. OC. Hanger wires to be located adjacent to main runner/cross tee intersections. Hanger wires wrapped and twist-tied on 16d nails driven in to the side of joists at least 5 in. above the bottom face.

b. **Cross Tees** — Nom 4 ft long, 1-1/2 in. wide face, installed perpendicular to the main runners, spaced 16 in. OC. When **Batts and Blankets*** (Item 5) are used, cross tees spaced 16 in. OC. Additional cross tees or cross channels used at 8 in. from each side of butted gypsum board end joints. The cross tees or cross channels may be riveted or screw attached to the wall angle or channel to facilitate the ceiling installation.

c. **Cross Channels** — Nom 4 ft long, installed perpendicular to main runners, spaced 16 in. OC. When **Batts and Blankets*** (Item 5) are used, cross channels spaced 16 in. OC.

d. **Wall Angle or Channel** — Painted or galv steel angle with 1 in. legs or channel with 1 in. legs, 1-9/16 in. deep attached to walls at perimeter of ceiling with fasteners 16 in. OC. To support steel framing member ends and for screw-attachment of the gypsum board.

CGC INC — Type DGL or RX

USG INTERIORS LLC — Type DGL or RX

6D. **Steel Framing Members*** — (Not Shown) As an alternate to Item 6, furring channels and **Steel Framing Members** as described below:

a. **Furring Channels** — Formed of No. 25 MSG galv steel, 2-9/16 in. or 2-23/32 in wide by 7/8 in. deep, spaced 24 in. OC perpendicular to joists. Channels secured to joists as described in Item b. Ends of adjoining channels overlapped 6 in. and tied together with double strand of No. 18 SWG galv steel wire near each end of overlap.

b. **Steel Framing Members*** — Used to attach furring channels (Item a) to joists (Item 2). Clips spaced 48 in. OC., and secured to alternating joists with No. 8 x 2-1/2 in. coarse drywall screw through the center grommet. Furring channels are friction fitted into clips. RSIC-1 clip for use with 2-9/16 in. wide furring channels. RSIC-1 (2.75) clip for use with 2-23/32 in. wide furring channels. Adjoining channels are overlapped as described in Item a. As an alternate, ends of adjoining channels may be overlapped 6 in. and secured together with two self-tapping No. 6 framing screws, min 7/16 in. long at the midpoint of the overlap, with one screw on each flange of the channel. Additional clips required to hold furring channel that supports the gypsum board butt joints, as described in Item 7.

PAC INTERNATIONAL L L C — Types RSIC-1, RSIC-1 (2.75)

6E. **Steel Framing Members*** — (Not Shown) — As an alternate to Item 6. For use in corridors or rooms having a maximum width dimension of 14 ft. Steel framing members consist of grid runners, locking angle wall molding and hanger bars. Locking angle wall molding secured to walls with steel nails or screws spaced max 24 in. OC. Slots of locking angle wall molding parallel with hanger bars to be aligned with tabbed cutouts in bottom edge of hanger bars. Hanger bars spaced max 50 in. OC and suspended with No. 12 AWG steel hanger wires spaced max 48 in. OC. Adjoining lengths of hanger bar to overlap 12 in. and to be secured together and suspended by a shared hanger wire. A min clearance of 1/4 in. shall be maintained between the ends of the hanger bars and the walls. Grid runners cut-to-length and installed perpendicular to hanger bars and spaced max 24 in. OC with additional grid runners installed 8 in. OC at gypsum board end joints. Grid runners parallel with walls to be spaced max 16 in. from wall. Ends of grid runners to rest on and engage slots of locking angle wall molding with a clearance of 3/8 in. to 1/2 in. maintained between each end of the grid runner and the wall. Bulb of grid runner to be captured by tabbed cutouts in bottom edge of hanger bars.

ARMSTRONG WORLD INDUSTRIES INC — Type DFR-8000-SS

6F. **Steel Framing Members*** — (Not Shown) — As an alternate to Item 6. Main runners nom 12 ft long, spaced 72 in. OC. Cross tees, nom 6 ft long, installed perpendicular to main runners and spaced 24 in. OC. Additional 6 ft long cross tees required at each gypsum board end joint with butted gypsum board end joints centered between cross tees spaced 8 in. OC. The main runners and cross

tees may be riveted or screw-attached to the wall angle or channel to facilitate the ceiling installation.

ARMSTRONG WORLD INDUSTRIES INC — Type DFR-8000

6G. **Resilient Channels** — (Not Shown) - As an alternate to Item 6. Resilient channels, formed from No. 25 MSG galv steel and shaped as shown, spaced 12 in. OC perpendicular to joist. Channels overlapped 4 in. at splices and secured to each joist with 1-1/4 in. Type S screws. Min end clearance of channels to wall to be 1/2 in. Additional resilient channels positioned so as to coincide with end joints of gypsum board (Item 7B or 7C).

6H. **Steel Framing Members*** — (Not Shown) — As an alternate to Item 6, furring channels and Steel Framing Members as described below.

a. **Furring Channels** — Formed of No. 25 MSG galv steel, 2-3/8 in. wide by 7/8 in deep, spaced 24 in OC, perpendicular to joists. Channels secured to joists as described in Item b. Ends of adjoining channels overlapped 6 in. and tied together with double strand of No. 18 SWG galv steel wire near each end of overlap.

b. **Steel Framing Members*** — Used to attach furring channels (Item a) to the wood joists (Item 2). Clips spaced 48 in. OC., and secured to alternating joists with No. 8 x 2-1/2 in. coarse drywall screw through the center grommet. Furring channels are friction fitted into clips. Adjoining channels are overlapped as described in Item a. As an alternate, ends of adjoining channels may be overlapped 6 in. and secured together with two self-tapping No. 6 framing screws, min 7/16 in. long at the midpoint of the overlap, with one screw on each flange of the channel. Additional clips required to hold furring channel that supports the gypsum board butt joints, as described in Item 7.

PLITEQ INC — Type Genie Clip

6I. **Steel Framing Members*** — (Not Shown) — As an alternate to Item 6, furring channels and Steel Framing Members as described below.

a. **Furring Channels** — Formed of No. 25 MSG galv steel, 2-5/8 in. wide by 7/8 in deep, spaced 24 in OC, perpendicular to joists. Channels secured to joists as described in Item b.

b. **Steel Framing Members*** — Used to attach furring channels (Item a) to the wood joists (Item 2). Clips spaced at 48 in. OC and secured to the bottom of the joists with one 2 in. Coarse Drywall Screw with 1 in. diam washer through the center hole. Furring channels are then friction fitted into clips. Ends of channels are overlapped 6" and tied together with double strand of No. 18 AWG galvanized steel wire. Additional clips are required to hold the Gypsum Butt joints as described in Item 7.

STUDCO BUILDING SYSTEMS — RESILMOUNT Sound Isolation Clips - Type A237 or A237R

6J. **Steel Framing Members*** — (Not Shown) — As an alternate to Item 6 Main runners nom 12 ft long, spaced 72 in. OC. Main runners suspended by min 12 SWG galv steel hanger wires spaced 48 in. OC. Cross tees, nom 6 ft long, installed perpendicular to main runners and spaced 24 in. OC. Additional 6 ft long cross tees required at each gypsum board end joint with butted gypsum board end joints centered between cross tees spaced 8 in. OC. The main runners and cross tees may be riveted or screw attached to the wall angle or channel to facilitate the ceiling installation.

USG INTERIORS LLC — Type DGL or RX

6K. **Steel Framing Members*** — (Not Shown) — As an alternate to Item 6 Main runners nom 12 ft long, spaced 48 in. OC. Cross tees, nom 4 ft. long, installed perpendicular to main runners and spaced 24 in. OC. Additional 4 ft. long cross tees required at 6 in. from each side of butted gypsum

board end joints. When **Batts and Blankets*** (Item 5B) are used, cross tees spaced 16 in. OC with additional cross tees 8 in. away from each side of butted gypsum board end joints. The cross tees shall be riveted with 1/8 in. dia. rivets to the wall angle and to the main tee where the cross tee does not align with slot in the main tee. Galvanized steel wall angle with 1-1/2 in. legs attached to walls at perimeter of ceiling with fasteners at 16 in. OC. to support steel framing member ends and for screw-attachment of the gypsum board.

CERTAINTEED CORP — Types DWS12-13-20, DWS4.16-13-20, DWS4-13-20, DWS2-13-20, DWS2.16-13-20 and DWA1.5-1.5

CERTAINTEED CORP — Types EZDWS12-13-18, EZDWS4.16-13-18, EZDWS4-13-18, EZDWS2-13-18, EZDWS2.16-13-18 and DWA1.5-1.5

6L. **Framing Members*** — (Not Shown) — As an alternate to Item 6. Main runners nom 12 ft long, spaced 72 in. OC. Main runners suspended by min 12 SWG galv steel hanger wires spaced 48 in. OC. Cross tees, nom 6 ft long, installed perpendicular to main runners and spaced 24 in. OC. Additional 6 ft long cross tees required at each gypsum board end joint with butted gypsum board end joints centered between cross tees spaced 8 in. OC. The main runners and cross tees may be riveted or screw attached to the wall angle or channel to facilitate the ceiling installation.

ROXUL USA INC. D/B/A ROCKFON — Type 670C

6M. **Steel Framing Members*** — (Not Shown) — As an alternate to Item 6, furring channels and Steel Framing Members as described below.

a. **Furring Channels** — Formed of No. 25 MSG galv steel, 2-1/2 in. wide by 7/8 in deep, spaced 24 in OC, perpendicular to joists. Channels secured to joists as described in Item b.

b. **Steel Framing Members*** — Used to attach furring channels (Item a) to the wood joists (Item 2). Clips spaced at 48 in. OC and secured to the bottom of the joists with one 2-1/2 in. Coarse Drywall Screw with 1 in. diam washer through the center hole. Furring channels are then friction fitted into clips. Ends of channels are overlapped 6" and tied together with double strand of No. 18 AWG galvanized steel wire. Additional clips are required to hold the Gypsum Butt joints as described in Item 7.

REGUPOL AMERICA — Type SonusClip

6M. **Steel Framing Members*** — (Not Shown) As an alternate to Item 6, furring channels and **Steel Framing Members** as described below:

a. **Furring Channels** — Formed of No. 25 MSG galv steel, 2-23/32 in wide by 7/8 in. or 1-1/2 in. deep, spaced 24 in. OC perpendicular to joists. Channels secured to joists as described in Item b. Ends of adjoining channels overlapped 6 in. and tied together with double strand of No. 18 SWG galv steel wire near each end of overlap.

b. **Steel Framing Members*** — Used to attach furring channels (Item a) to joists (Item 2). Clips spaced 48 in. OC., and secured to alternating joists with No. 8 x 2-1/2 in. coarse drywall screw through the center grommet. Furring channels are friction fitted into clips. Adjoining channels are overlapped as described in Item a. As an alternate, ends of adjoining channels may be overlapped 6 in. and secured together with two self-tapping No. 6 framing screws, min 7/16 in. long at the midpoint of the overlap, with one screw on each flange of the channel. Additional clips required to hold furring channel that supports the gypsum board butt joints, as described in Item 7.

CLARKDIETRICH BUILDING SYSTEMS — Type ClarkDietrich Sound Clip

6N. Steel Framing Members* — (Optional, Not Shown) — As an alternate to Item 6.

a. **Furring Channels** — Formed of No. 25 MSG galv steel, nominal 2-1/2 in. wide by 7/8 in. deep, spaced 24 in. OC, perpendicular to the joists. Channels secured to Cold Rolled Channels at every intersection with a 3/4 in. TEK screw through each furring channel leg. Ends of adjoining channels overlapped 12 in. and fastened together with two double strand No. 18 SWG galv steel wire ties, one at each end of overlap, or with two 3/4 in. TEK screws in each leg of the overlap section. Two furring channels positioned 3 in. OC, 1-1/2 in. on each side of gypsum board (Item 7) end joints, each extending a min of 6 in. beyond both side edges of the board.

b. **Cold Rolled Channels** — 1-1/2 in. by 1/2 in., formed from No. 16 ga. galv steel, positioned vertically and parallel to joists, friction-fitted into the channel caddy on the Steel Framing Members (Item 6Nc) and secured with two 3/4 in. TEK screws. Adjoining lengths of cold rolled channels lapped min. 12 in. and secured along bottom legs with four 3/4 in. TEK screws and wire-tied together with two double strand 18 SWG galv steel wire ties, one at each end of overlap.

c. **Steel Framing Members*** — Spaced 48 in. OC. max along joist, and secured to the joist on alternating joists with two, #10 x 1-1/2 in. screws through mounting holes on the hanger bracket.

PAC INTERNATIONAL L L C — Type RSIC-SI-CRC EZ Clip

6O. Steel Framing Members* — (Optional, Not Shown) — As an alternate to Item 6.

a. **Furring Channels** — Formed of No. 25 MSG galv steel, nominal 2-1/2 in. wide by 7/8 in. deep, spaced 24 in. OC perpendicular to joists and friction fit into Steel Framing Members (Item 6Ob). Ends of adjoining channels overlapped 6 in. and tied together with double strand of No. 18 SWG galv steel wire near each end of overlap or with two TEK screws along each leg of the 6 in. overlap. Two furring channels positioned 6 in. OC, 3 in. on each side of gypsum board (Item 7) end joints. Butt joint channels held in place by strong back channels placed upside down, on top of, and running perpendicular to primary furring channels, extending 6 in. longer than length of gypsum side joint. Strong back channels spaced maximum 48 in. OC. Strong back channels secured to every intersection of primary furring channels with four 7/16 in. pan head screws, two along each of the legs at intersections. Butt joint channels run perpendicular to strong back channels and shall be minimum 6 in. longer than length of joint, secured to strong back channels with 7/16 in. pan head screws, two along each of the legs at intersection with strong back channels.

b. **Steel Framing Members*** — Used to attach furring channels (Item 6Oa) to joists. Clips spaced 48 in. OC and secured along joist webs at each furring channel intersection with min. 3/4 in. long self-drilling #10 x 1-1/2 in. screws through each of the provided hole locations. Furring channels are friction fitted into clips.

PAC INTERNATIONAL L L C — Type RSIC-S1-1 Ultra

6P. Steel Framing Members* — (Optional, Not Shown) — Used as an alternate method to attach resilient channels to structural members. A resilient sound isolation accessory shall be used at each attachment point of the resilient channels and spaced max 16 in. O.C. Channel ends butted and centered under the structural members and attached with one accessory at each end. Additional accessories used to hold resilient channels that support the gypsum board end joints, as described in Item 7. The accessory envelops the mounting edge of the resilient channel. The accessory and resilient channel are fastened to the structural members with the screws supplied with the accessory and per the accessory manufacturer's installation instructions. Gypsum Board butt joints staggered minimum 24 in. OC and Gypsum Board screws spaced 8 in. OC when used.

PAC INTERNATIONAL L L C — Types RC-1 Boost

7. **Gypsum Board*** — Nom 1/2 in. thick, 4 ft wide gypsum board. When resilient channels (Item 6) are used, gypsum board installed with long dimension perpendicular to resilient channels and side joints of sheet located between joists. Nom 1 in. long No. 6 Type S bugle head screws are driven through channel spaced 12 in. OC. End joints of gypsum board similarly fastened to additional resilient channels positioned at end joint locations. Screws shall be spaced 1/2 in. from end joints. When **Steel Framing Members*** (Item 6A, 6B, 6C) are used, nom 1/2 in. thick, 4 ft wide gypsum board installed with long dimension perpendicular to cross tees with side joints centered along main runners and end joints centered along cross tees. Gypsum board secured to cross tees with 1 in. long No. 6 Type S bugle head screws spaced 12 in. OC in the field and 8 in OC along end joints. Adjacent gypsum board sheets held to the end joint furring channel by means of one 1 in. long No. 6 Type S bugle head screw on each side of the end joints. All edge screws located 3/8 to 1/2-in. min distance from edges of gypsum board sheets to main runners with 1 in. long No. 6 Type S bugle head screws spaced 16 in. OC, midway between cross tees. Screws along sides and ends of boards spaced 1/2 in. from board edge. End joints of the sheets shall be staggered with spacing between joints on adjacent boards not less than 4 ft OC.

When **Steel Framing Members*** (Item 6D, 6H) are used, nom 1/2 in. thick, 4 ft wide gypsum board installed with long dimension perpendicular to furring channels and side joints of sheet located beneath joists. Nom 1 in. long No. 6 Type S bugle head screws are driven through channel spaced 12 in. OC in the field. Gypsum board butt joints shall be staggered min. 2 ft. within the assembly, and occur between the main furring channels. At the gypsum board butt joints, each end of each gypsum board shall be supported by a single length of furring channel equal to the width of the gypsum board plus 6 in. on each end. The two furring channels shall be spaced approximately 3-1/2 in. OC, and be attached to the joist with one clip at each end of the channel. Screw spacing along the butt joint to attach the gypsum board to the furring channels shall be 8 in. OC. Joint treatment not required for this rating, except for tapered, rounded-edge gypsum board where edge joints are covered with paper tape and joint compound. As an alternate, nom 3/32 in. thick gypsum veneer plaster may be applied to the entire surface of Classified veneer baseboard. Joints reinforced.

When alternate **Steel Framing Members*** (Item 6E) are used, nom 1/2 in. thick, 4 ft wide gypsum board sheets installed with long dimension (side joints) perpendicular to the grid runners with the end joints staggered min 4 ft and centered between grid runners which are spaced 8 in. OC. Prior to installation of the gypsum board sheets, backer strips consisting of nom 7-3/4 in. wide by 48 in. long pieces of gypsum board are to be laid atop the grid runner flanges and centered over each butted end joint location. The backer strips are to be secured to the flanges of the grid runners at opposite corners of the backer strip to prevent the backer strips from being uplifted during screw-attachment of the gypsum board sheets. Gypsum board fastened to grid runners with drywall screws spaced 1 in. and 4 in. from the side joints and max 8 in. OC in the field of the board. The butted end joints are to be secured to the backer strip with No. 10 by 1-1/2 in. long Type G laminating screws located 1 in. from each side of the butted end joint and spaced 1 in. and 4 in. from the side joints and max 8 in. OC in the field of the board.

When alternate **Steel Framing Members*** (Item 6F) are used, nom 1/2 in. thick, 4 ft wide gypsum board sheets installed with long dimension (side joints) perpendicular to the 6 ft long cross tees with the end joints staggered min 4 ft and centered between cross tees which are spaced 8 in. OC. Gypsum board side joints may occur beneath or between main runners. Prior to installation of the

gypsum board sheets, backer strips consisting of nom 7-3/4 in. wide pieces of gypsum board are to be laid atop the cross tee flanges and centered over each butted end joint location. The backer strips are to be secured to the flanges of the cross tees at opposite corners of the backer strip to prevent the backer strips from being uplifted during screw-attachment of the gypsum board sheets. Gypsum board fastened to cross tees with drywall screws spaced 1 in. and 4 in. from the side joints and max 8 in. OC in the field of the board. The butted end joints are to be secured to the backer strip with No. 10 by 1-1/2 in. long Type G laminating screws located 1 in. from each side of the butted end joint and spaced 1 in. and 4 in. from the side joints and max 8 in. OC in the field of the board.

When **Steel Framing Members** (Item 6I) are used, one layer of nom 5/8 in. thick, 4 ft wide gypsum board is installed with long dimensions perpendicular to furring channels. Gypsum board secured to furring channels with nom 1 in. long Type S bugle-head steel screws spaced 8 in. OC in the field of the board. Gypsum board butted end joints shall be staggered minimum 48 in. and centered over main furring channels. At the gypsum board butt joints, each end of each gypsum board shall be supported by a single length of furring channel equal to the width of the gypsum board plus 3 in. on each end. The two support furring channels shall be spaced approximately 3 in. in from joint. Screw spacing along the gypsum board butt joint and along both additional channels shall be 8 in. OC. Additional screws shall be placed in the adjacent section of gypsum board into the aforementioned 3 in. extension of the extra butt joint channels as well as into the main channel that runs between butt joint furring channels shall be attached with one RESILMOUNT Sound Isolation Clip at each end of the channel.

When alternate **Steel Framing Members*** (Item 6J or 6L) are used, nom 1/2 in. thick, 4 ft wide gypsum board sheets installed with long dimension (side joints) perpendicular to the 6 ft long cross tees with the end joints staggered min 4 ft and centered between cross tees which are spaced 8 in. OC. Gypsum board side joints may occur beneath or between main runners. Prior to installation of the gypsum board sheets, backer strips consisting of nom 7-3/4 in. wide pieces of gypsum board are to be laid atop the cross tee flanges and centered over each butted end joint location. The backer strips are to be secured to the flanges of the cross tees at opposite corners of the backer strip with hold down clips to prevent the backer strips from being uplifted during screw-attachment of the gypsum board sheets. Gypsum board fastened to cross tees with 1 in. drywall screws spaced 1 in. and 4 in. from the side joints and max 8 in. OC in the field of the board. The butted end joints are to be secured to the backer strip with No. 10 by 1-1/2 in. long Type G laminating screws located 1 in. from each side of the butted end joint and spaced 1 in. and 4 in. from the side joints and max 8 in. OC in the field of the board.

When **Steel Framing Members** (Item 6M) are used, one layer of nom 5/8 in. thick, 4 ft wide gypsum board is installed with long dimensions perpendicular to furring channels. Gypsum board secured to furring channels with nom 1 in. long Type S bugle-head steel screws spaced 8 in. OC in the field of the board. Gypsum board butted end joints shall be staggered minimum 48 in. and centered over main furring channels. At the gypsum board butt joints, an additional single length of furring channel shall be installed and be spaced approximately 3 in. from the butt joint (6 in. from the continuous furring channels) to support the floating end of the gypsum board. Each of these shorter sections of furring channel shall extend one joist beyond the width of the gypsum panel and be attached to the adjacent joists with one SonusClip at every joist involved with the butt joint.

When **Steel Framing Members** (Item 6N) are used, one layer of nom 1/2 in. thick, 4 ft wide gypsum board, installed as described in Item 7. Adjacent butt joints staggered minimum 48 in. OC.

When **Steel Framing Members** (Item 6O) are used, one layer of nom 1/2 in. thick, 4 ft wide gypsum board, installed as described in Item 7. Butt joints staggered minimum 24 in. OC.

AMERICAN GYPSUM CO — Type AG-C

CABOT MANUFACTURING ULC — Type C

CERTAINTEED GYPSUM INC — Type C, Type LGFC-C/A

CGC INC — Types C, IP-X2, IPC-AR, WRC

CERTAINTEED GYPSUM INC —

GEORGIA-PACIFIC GYPSUM L L C — Types 5, C, GPFS1, DAP, DA, DAPC, TG-C

NATIONAL GYPSUM CO — Types eXP-C, FSK-C, FSW-C

PABCO BUILDING PRODUCTS L L C, DBA PABCO GYPSUM — Types PG-1, PG-3, PG-C

THAI GYPSUM PRODUCTS PCL — Type C

UNITED STATES GYPSUM CO — Types C, IP-X2, IPC-AR, WRC

USG BORAL DRYWALL SFZ LLC — Type C

USG MEXICO S A DE C V — Types C, IP-X2, IPC-AR, WRC

7A. **Gypsum Board*** — For use when **Batts and Blankets*** (Item 5) and **Steel Framing Members*** (Item 6C) are used. Nom 5/8 in. thick, 4 ft wide gypsum board installed with long dimension perpendicular to cross tees with side joints centered along main runners and end joints

centered along cross tees. Fastened to cross tees with 1 in. long No. 6 Type S bugle head screws spaced 8 in. OC in the field and 8 in. OC along end joints. Fastened to main runners with 1 in. long No. 6 Type S bugle head screws spaced midway between cross tees. Screws along sides and ends of boards spaced 3/8 to 1/2 in. from board edge. End joints of the sheets shall be staggered with spacing between joints on adjacent boards not less than 4 ft OC.

CGC INC — Types C, IP-X2, IPC-AR, WRC

UNITED STATES GYPSUM CO — Types C, IP-X2, IPC-AR, WRC

USG BORAL DRYWALL SFZ LLC — Type C

USG MEXICO S A DE C V — Types C, IP-X2, IPC-AR, WRC

7B. **Gypsum Board*** — For use when **Batts and Blankets*** (Item 5) and Resilient Channels (Item 6G) are used. Nom 5/8 in. thick, 4 ft wide gypsum board installed with long dimension perpendicular to resilient channels. Nom 1 in. long No. Type S bugle head screws are driven through channel spaced 8 in. OC. End joints of gypsum board similarly fastened to additional resilient channels positioned at end joint locations.

CERTAINTED GYPSUM INC — Type C

7C. **Gypsum Board*** — For use when **Batts and Blankets*** (Item 5A) and Resilient Channels (Item 6G) are used. Nom 5/8 in. thick, 4 ft wide gypsum board installed with long dimension perpendicular to resilient channels. Nom 1 in. long No. Type S bugle head screws are driven through channel spaced 8 in. OC. End joints of gypsum board similarly fastened to additional resilient channels positioned at end joint locations.

AMERICAN GYPSUM CO — Type AG-C

CERTAINTED GYPSUM INC — Type LGFC-C/A

7D. **Gypsum Board*** — (Finish Rating - 16 min.) Required when Air Balance Inc. Type 299 ceiling damper (Item 4) is installed. Nom 5/8 in. thick, 48 in. wide gypsum board, installed and secured as described in items 7 and 7A.

UNITED STATES GYPSUM CO — Type C

USG BORAL DRYWALL SFZ LLC — Type C

USG MEXICO S A DE C V — Type C

7E. **Gypsum Board*** — For use when alternate **Steel Framing Members*** (Item 6K) are used - 1/2 in. thick, 4 ft. wide; installed with long dimension parallel to main runners and perpendicular to the 4 ft. long cross tees with the end joints centered between cross tees which are spaced 6 in. OC. Sheets are attached to cross tees with screws spaced 8 in. OC on the ends and 12 in. OC in the field with additional screws located 1-1/2 in. from the side edges. Sheets are attached to the main tees with screws spaced 8 in. OC with additional screws located 4 in. OC from the edges. Screws on the sides are located 1/2 in. from the side edge of the gypsum board. When **Batts and Blankets*** (Item 5B) are used - 5/8 in. thick, 4 ft. wide; installed with long dimension parallel to main runners and perpendicular to cross tees and attached with screws spaced 8 in. OC on the ends and 8 in. OC in the field with additional screws located 1-1/2 in. from the side edges. Sheets are attached to main tees with screws spaced 8 in. OC with additional screws located 4 in. OC from the side edges. Screws on the sides located 3/4 in. from the side edge of the gypsum board, and screws at the end of the gypsum board located 1/2 in. from the board ends. Joints to be covered with paper tape and joint compound.

CERTAINTED GYPSUM INC — Type C

7F. **Gypsum Board*** — As an alternate to Items 7, 7A and 7D. Nom 5/8 in. thick, 4 ft wide gypsum boards installed as described in Item 7 with screws spaced at max. 8 in. OC.

CGC INC — Type ULIX

UNITED STATES GYPSUM CO — Type ULIX

8. **Finishing System (Not Shown)** — Vinyl, dry or premixed joint compound, applied in two coats to joints and screw-heads. Nom 2 in. wide paper tape embedded in first layer of compound over all joints. As an alternate, nom 3/32 in. thick veneer plaster may be applied to the entire surface of gypsum board.

9. **Grille** — Steel grille installed in accordance with the installation instructions provided with the ceiling damper.

10. **Discrete Products Installed in Air-handling Spaces*** — Automatic Balancing Valve/Damper — (Not Shown - Optional) — For use with item 4, Ruskin Company's Model CFD7 damper (CABS). Ceiling damper to be provided with plenum box per damper manufacturer's instructions with side outlet only. Entire assembly to be installed into any UL Class 0 or Class 1 flexible air duct in accordance with the instructions provided by the automatic balancing valve/damper manufacturer.

METAL INDUSTRIES INC — Model ABV-4, ABV-5, ABV-6

*** Indicates such products shall bear the UL or cUL Certification Mark for jurisdictions employing the UL or cUL Certification (such as Canada), respectively.**

Last Updated on 2023-04-04