

## Design No. H505

June 30, 2020

### Unrestrained Assembly Rating —1 and 2 Hr (Refer to Item 4)

This design was evaluated using a load design method other than the Limit States Design Method (e.g., Working Stress Design Method). For jurisdictions employing the Limit States Design Method, such as Canada, a load restriction factor shall be used — See Guide [BXUV](#) or [BXUV7](#)

\* Indicates such products shall bear the UL or cUL Certification Mark for jurisdictions employing the UL or cUL Certification (such as Canada), respectively.

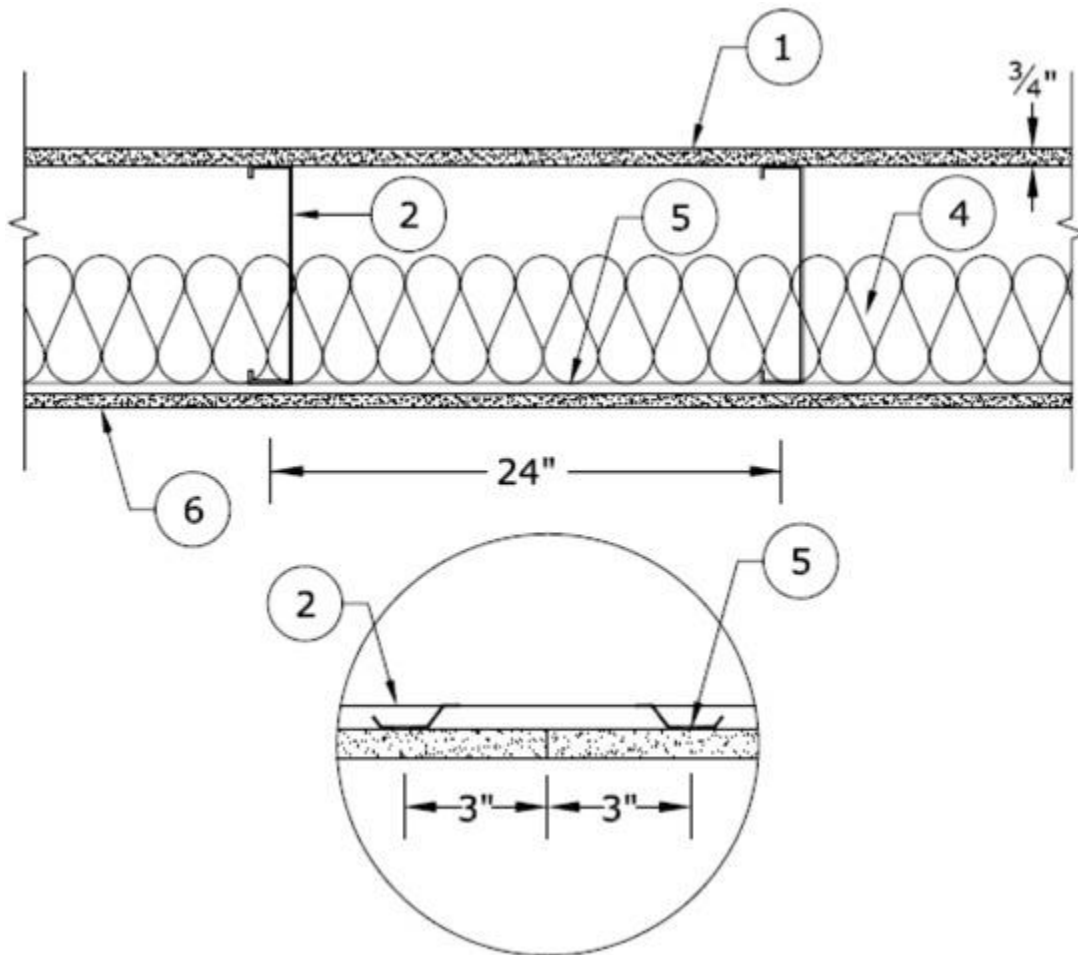

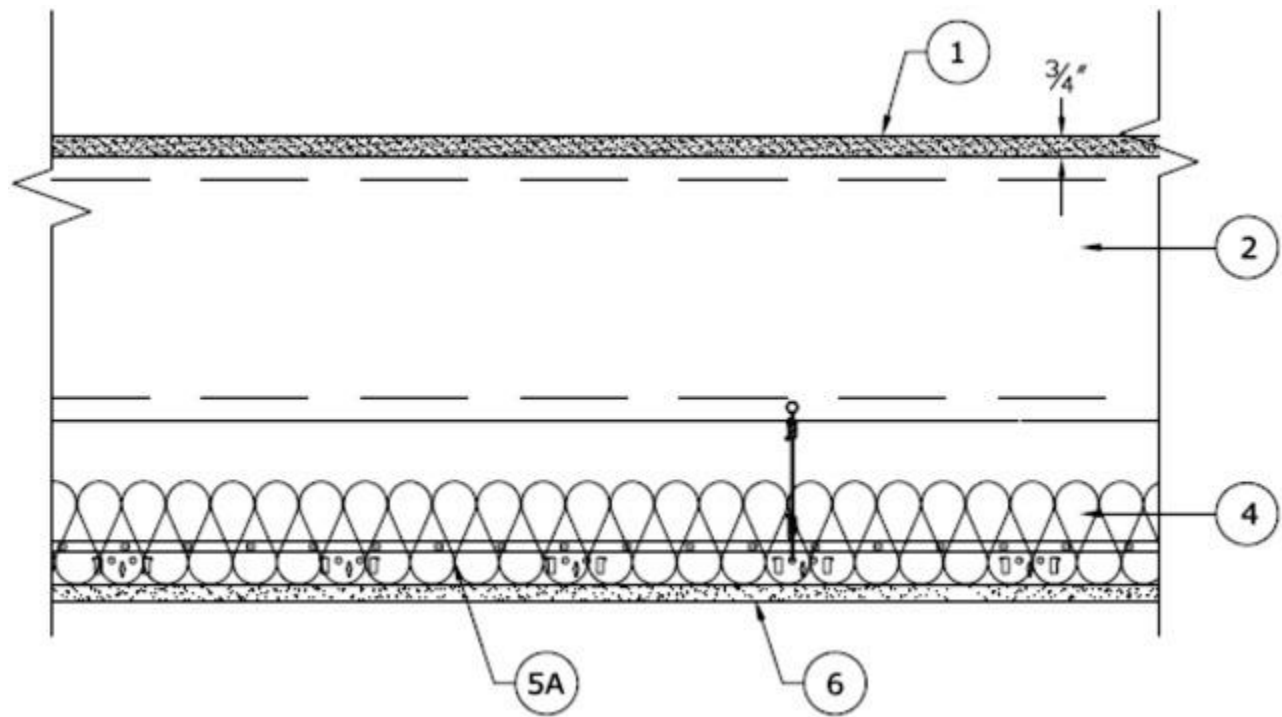

1. **Structural Cement-Fiber Units\*** — Nom 3/4 in. thick, with long edges tongue and grooved. Long dimension of panels to be perpendicular to joists with end joints staggered a min of 2 ft and centered over the joists. Panels secured to steel joists with 1-5/8 in. long No. 8 self-drilling, self-countersinking steel screws spaced a max of 12 in. OC in the field with a screw located 1 in. and 2 in. from each edge, and 8 in. OC on the perimeter with a screw located 2 in. from each edge, located 1/2 in. from the side edges of the panel.

As an alternate to the 1-5/8" long No. 8 fastener, the following power-actuated pins may be used for min. 1/8" thick, hot-rolled A36 steel sections for joist specified in Item 2E:

Hilti pin model X-U 32MX with a min. 0.157" shank diameter min. 1-1/4" long, DeWalt pin model 50458-PWR with a min. 0.157" shank diameter min. 1-1/4" long or Aerosmith model 5324HPG with a min. 0.145 shank diameter min. 1-1/4" long.

**UNITED STATES GYPSUM CO** — Types STRUCTO-CRETE, USGSP

2. **Steel Joists** — Channel-shaped, min 8 in. deep with min 1-5/8 in. wide flanges and 1/2 in. long stiffening flanges. Fabricated from min No. 16 MSG galv steel. Min yield strength of 50,000 psi. Joists spaced max 24 in. OC. Supplied with appropriate rim tracks of same size and gauge.

2A. **Clip Angles** — (Not Shown) - 18 MSG, 7-1/4 in. long steel angles with 1-1/2 in. legs for 8 in. deep joists. Secured to track and joist with six No.10, 3/4 in. long, self -drilling, hex head screws, located 1 in. from each end of the clip angle and at the centerline. Only one clip angle per joist end.

2B. **Structural Steel Members\*** — (Not Shown) - As an alternate to Item 2, - Pre-fabricated steel truss system consisting of cold-formed, galvanized steel chord and web sections. Truss top and bottom chords min. 4 in. high by 1-11/16 in. wide by 18 ga. Truss webs min. 1-1/2 in. by 1-1/2 in. by 20 ga. square tube bent and triangulated as shown. Chords and web connected by fillet welds. Overall truss depth min. 12 in. Trusses spaced a max of 24 in. OC. Truss ends placed over and secured to Bearing Seats (Item 2B1) with two min. #10 by 3/4 in. long screws on each side of Bearing Seats. Allowable loading must be calculated so as to stress the steel trusses to a maximum of 98% of the stress calculated in accordance with the allowable stress design approach outlined in the manufacturer's load tables.

**EISEN PANEL SYSTEMS L L C** — Type Gateway Panel pre-fabricated steel truss system.

2B1. **Bearing Seats\*** — (Not Shown) — Galvanized steel tube, min. 1 in. by 2-1/2 in. by 13 ga., oriented vertically and welded to min. 4 in. by 4 in. by 10 ga., galvanized steel plate. Bearing seats spaced 24 in. OC and attached to bearing supports by welding or screw attaching the steel plate to the bearing supports.

**EISEN PANEL SYSTEMS L L C** — Type Gateway Panel bearing seat.

2B2. **Bracing** — (Not Shown) - For use with Item 2B — Galvanized channel-shaped steel sections, min. 1-1/2 in. wide with 1/4 in. flanges, min. 16 ga. Bracing attached to underside of trusses with min. #10 by 3/4 in. long screws through truss bottom chord. Bracing installed in truss cavities by scoring, bending and flattening the ends to form a tab for attachment to truss top and bottom chords. Two pieces of bracing crossed and tabs secured to truss chords with min. #10 by 3/4 in. long screws. Location and spacing of underside and crossed bracing to be specified on truss engineering.

2C. **Structural Steel Members\*** — As an alternate to Item 2 — Pre-fabricated light gauge steel truss system consisting of cold-formed, galvanized steel cord and web sections. Trusses fabricated in various sizes, depths, and from various steel thickness. Trusses minimum 12 in. deep, spaced a max of 24 in. OC.

**AEGIS METAL FRAMING, DIV OF MITEK** — Ultra-Span, Pre-fabricated Light Gauge Steel Truss System

**TRUSSTEEL, DIV OF ITW BUILDING COMPONENTS INC** — TrusSteel

2D. **Steel Trusses** — As an alternate to Item 2, - Cold-formed galvanized steel truss chord and web sections manufactured from steel conforming to ASTM A653 Grade 33 or higher yield strength. Steel thickness of truss chord and web sections as required by design to meet governing code requirements. Truss members connected together with No. 10-16 (min size) self-drilling screws or equivalent. Truss chord and web members to be designed in accordance with the American Iron and Steel Institute's Specification for the Design of Cold-Formed Steel Structural Members, 1996 Edition. Trusses spaced a max of 24 in. OC. Where the truss intersects with the interior face of the exterior walls, the min truss depth shall be 12 in.

2E. **Steel Joists** — As an alternate to Item 2, minimum 12K1, spaced a max 24 in. OC.

2F. **Structural Steel Members\*** — As an alternate to Item 2 - Limited to the 1 Hour Ratings. Pre-fabricated light gauge steel truss system consisting of cold-formed, galv steel cord and web sections. Trusses fabricated in various sizes, depths and from various steel thickness. Trusses spaced a max of 24 in. OC. Location of lateral bracing for truss chord and web sections to be specified on truss engineering.

**TRUSS LINK INC** — Truss Link

3. **Joist Bridging** — (Not Shown) - For use with Item 2 — Installed immediately after joists are erected and before construction loads are applied. The bridging shall consist of rim track cut 8 in. longer than span between joists, with rim track legs cut through 4 inches back from each end and bent at a 90° angle and screw attached through the rim track legs into the joists with four screws at each end, two on top and two on the bottom at each end of rim track. Flat strap bracing of 1-1/2 in. wide by 20-ga galvanized steel is also screw-attached to bottom joist flange at mid-span.

4. **Batts and Blankets\*** — (When Insulation is not used the rating shall be 1 Hr.). 3-1/2 in. thick glass fiber batt insulation draped over the resilient channels. Any glass fiber batt insulation bearing the UL Classification Marking for Surface Burning Characteristics having a flame spread index of 25 or less and a smoke developed index of 50 or less may be used. See **Batts and Blankets** (BKNV) category in the Building Materials Directory for names of manufacturers.

5. **Resilient Channels** — Formed of No. 25 MSG galv steel, 1/2 in. deep, spaced max 12 in. OC, perpendicular to joists. Channel splices located beneath joists and overlapped 4 in. Channels secured to each joist with one 1/2 in. long Type S-12 low profile steel screw. Two channels, spaced 6 in. OC, oriented opposite each gypsum board end joint as shown on the illustration above. Additional channels shall extend min 6 in. beyond each side edge of board.

5A. **Steel Framing Members\*** — (Optional, Not Shown) — When it is desired to drop the ceiling below the bottom plane of the structural steel members (Item 2), a suspension system may be used in lieu of the resilient channels. Main runners, cross tees, cross channels and wall angle as listed below:

a. **Main Runners** — Nom 10 or 12 ft long , 15/16 in. or 1-1/2 in. wide face, spaced 4 ft. OC. Main runners suspended by min 12 SWG galv steel hanger wires spaced 24 in. OC, a min of 4 in. below bottom flange of joist, twist-tied to #10 -3/4 in. long screws installed in the web, 1/2 in. from the bottom flange of the steel joist. Hanger wires to be located adjacent to main runner/cross tee intersections.

b. **Cross Tees** — Nom 4 ft long, 1-1/2 in. wide face, installed perpendicular to the main runners, spaced 16 in. OC. Additional cross tees or cross channels used at 8 in. from each side of butted gypsum panel end joints. The cross tees or cross channels may be riveted or screw attached to the wall angle or channel to facilitate the ceiling installation.

c. **Cross Channels** — Nom 4 ft or 12 ft long, installed perpendicular to main runners, spaced 16 in. OC.

d. **Wall Angle or Channel** — Painted or galv steel angle with 1 in. legs or channel with 1 in. legs, 1-9/16 in. deep attached to walls at perimeter of ceiling with fasteners 16 in. OC. To support steel framing member ends and for screw-attachment of the gypsum panel.

**CGC INC** — Type DGL or RX

**USG INTERIORS LLC** — Type DGL or RX.

5B. **Steel Framing Members\*** — (Optional, Not Shown) — As an alternate to Item 5 — Furring channels and Steel Framing Members as described below:

a. **Furring channels** — Formed of No. 25 MSG galv steel, 2-3/8 in. wide by 7/8 in. deep, spaced 12 in. OC, perpendicular to joists. Channel secured to joists as described in Item b. Ends of adjoining channels overlapped 6 in. and tied together with double strand of No. 18 SWG galv steel wire near each end of overlap.

Additional channels shall be positioned so that the distance from the end of the board to the center of the first channel is 3 in. and from the board end to the center of the next channel is 12 in.

b. **Steel Framing Members\*** — Used to attach furring channels (Item a) to joists (Item 2). Clips spaced 48 in. OC and secured to the bottom chord of joists with min 1-5/8 in. long No. 8 self-drilling, self-tapping, bugle, flat or hex head screw through the center grommet. Furring channels are friction fitted into clips. Additional clips required to hold furring channel that supports the gypsum board butt joints.

**PLITEQ INC** — Type Genie Clip

5C. **Alternate Steel Framing Members\*** — (Optional, Not Shown) — As an alternate to Items 5 to 5B, furring channels and Steel Framing Members as described below.

a. **Furring channels** — Formed of No. 25 MSG galv steel. 2-9/16 in. or 2-23/32 in. wide by 7/8 in. deep, spaced 12 in. OC, perpendicular to joists. Channels secured to joists as described in Item b. Ends of adjoining channels overlapped 6 in. and tied together with double strand of No. 18 SWG galv steel wire near each end of overlap.

b. **Steel Framing Members\*** — Used to attach furring channels (Item a) to the steel joists (Item 2). Clips spaced a max of 48 in. OC. RSIC-1 and RSIC-1 (2.75) clips secured to alternating joists with No. 8 x 2-1/2 in. coarse drywall screw through the center grommet. Furring channels are friction fitted into clips. RSIC-1 clips for use with 2-9/16 in. wide furring channels. RSIC-1 (2.75) clips for use with 2-23/32 in. wide furring channels. Adjoining channels are overlapped as described in Item a. As an alternate, ends of adjoining channels may be overlapped 6 in. and secured together with two self-tapping No. 6 framing screws, min. 7/16 in. long at the midpoint of the overlap, with one screw on each flange of the channel. Additional clips required to hold furring channel that supports the wallboard butt joints, as described in Item 6.

**PAC INTERNATIONAL L L C** — Types RSIC-1 or RSIC-1 (2.75)

5D. **Steel Framing Members\*** — (Optional, Not Shown) — As an alternate to Item 5.

a. **Furring Channels** — Formed of No. 25 MSG galv steel, nominal 2-1/2 in. wide by 7/8 in. deep, spaced 12 in. OC, perpendicular to the joists. Channels secured to Cold Rolled Channels at every intersection with a 3/4 in. TEK screw through each furring channel leg. Ends of adjoining channels overlapped 12 in. and fastened together with two double strand No. 18 SWG galv steel wire ties, one at each end of overlap, or with two 3/4 in. TEK screws in each leg of the overlap section. Two furring channels used at end joints of gypsum board (Item 6), each extending a min of 6 in. beyond both side edges of the board.

b. **Cold Rolled Channels** — 1-1/2 in. by 1/2 in., formed from No. 16 ga. galv steel, positioned vertically and parallel to joists, friction-fitted into the channel caddy on the Steel Framing Members (Item 5Dc) and secured with two 3/4 in. TEK screws. Adjoining lengths of cold rolled channels lapped min. 12 in. and secured along bottom legs with four 3/4 in. TEK screws and wire-tied together with two double strand 18 SWG galv steel wire ties, one at each end of overlap.

c. **Steel Framing Members\*** — Spaced 48 in. OC. max along joist, and secured to the joist on alternating joists with two, No. 10-16 TEK screws through mounting holes on the hanger bracket.

**PAC INTERNATIONAL L L C** — Type RSIC-SI-CRC EZ Clip

5E. **Steel Framing Members\*** — (Optional, Not Shown) — As an alternate to Item 5.

a. **Furring Channels** — Formed of No. 25 MSG galv steel, nominal 2-1/2 in. wide by 7/8 in. deep, spaced 12 in. OC perpendicular to joists and friction fit into Steel Framing Members (Item 5Eb). Ends of adjoining channels overlapped 6 in. and tied together with double strand of No. 18 SWG galv steel wire near each end of overlap or with two TEK screws along each leg of the 6 in. overlap. Two furring channels used at end joints of gypsum board (Item 6). Butt joint channels held in place by strong back channels placed upside down, on top of, and running perpendicular to primary furring channels, extending 6 in. longer than length of gypsum side joint. Strong back channels spaced maximum 48 in. OC. Strong back channels secured to every intersection of primary furring channels with four 7/16 in. pan head screws, two along each of the legs at intersections. Butt joint channels run perpendicular to strong back channels and shall be minimum 6 in. longer than length of joint, secured to strong back channels with 7/16 in. pan head screws, two along each of the legs at intersection with strong back channels.

b. **Steel Framing Members\*** — Used to attach furring channels (Item 5Ea) to joists. Clips spaced 48 in. OC and secured along joist webs at each furring channel intersection with min. 3/4 in. long self-drilling No. 10-16 TEK screws through each of the provided hole locations. Furring channels are friction fitted into clips.

**PAC INTERNATIONAL L L C** — Type RSIC-S1-1 Ultra

6. **Gypsum Board\*** — One layer of nom 5/8 in. thick by 48 in. wide gypsum panels installed with long dimension perpendicular to resilient channels, furring channels or cross tees of suspension system. Gypsum panels secured to resilient channels, furring channels or drywall suspension system with 1 in. long Type S bugle-head screws spaced 8 in. OC, with screws located minimum of 1 in. from the side joints and 3 in. from the end joints. End joints secured to both resilient/furring channels as shown in end joint detail. When **Steel Framing Members** (Item 5B or 5C) are used, the butt joints in the gypsum board shall be supported by two furring channels. The two furring channels shall be spaced approximately 3-1/2 in. OC, and be attached to underside of the joist with one RSIC-1, RSIC-1 (2.75) or Genie clip at each end of the channel.

When **Steel Framing Members** (Item 5D) are used, nom 5/8 in. thick, 4 ft wide gypsum board, installed as described in Item 6 as per hourly ratings. Adjacent butt joints staggered minimum 48 in. OC.

When **Steel Framing Members** (Item 5E) are used, nom 5/8 in. thick, 4 ft wide gypsum board, installed as described in Item 6 as per hourly ratings. Butt joints staggered minimum 24 in. OC.

**CGC INC** — Type ULIX

**UNITED STATES GYPSUM CO** — Type ULIX

7. **Finishing System - (Not Shown)** — Vinyl, dry or premixed joint compound, applied in two coats to joints and screw-heads. Nom 2 in. wide paper tape embedded in first layer of compound over all joints. As an alternate, nom 3/32 in. thick veneer plaster may be applied to the entire surface of gypsum panels.

**\* Indicates such products shall bear the UL or cUL Certification Mark for jurisdictions employing the UL or cUL Certification (such as Canada), respectively.**

[Last Updated](#) on 2020-06-30