

Design No. H502

Restrained Assembly Ratings - 1, 1-1/2 and 2 Hr. (see Items 2A, 7A, 8A and 9)

Unrestrained Assembly Ratings - 1, 1-1/2 and 2 Hr. (see Items 2A, 4 System No. 6, 7A, 8A, and 9)

Unrestrained Beam Ratings - 1, 1-1/2 and 2 Hr. (see Items 2A, 7A, 8A and 9)

*** Indicates such products shall bear the UL or cUL Certification Mark for jurisdictions employing the UL or cUL Certification (such as Canada), respectively.**

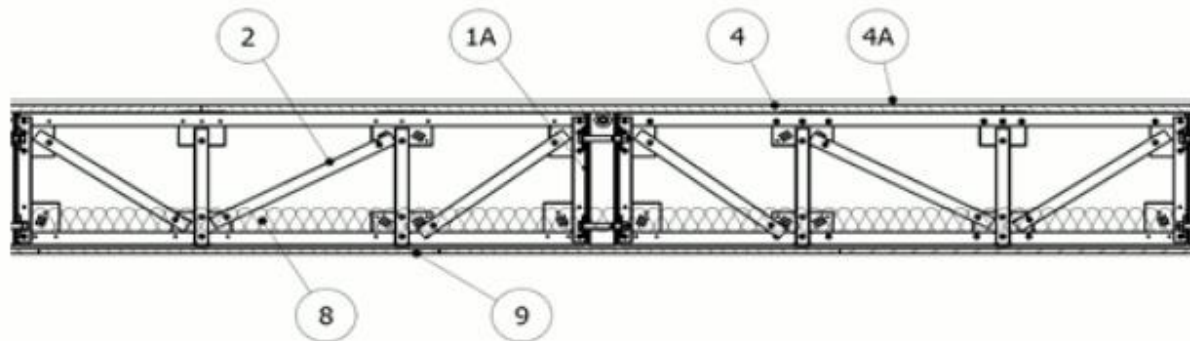
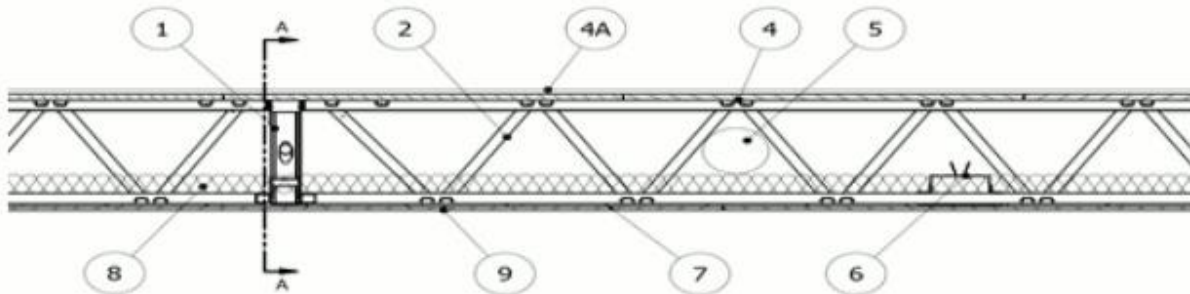

SECTION A-A

1. **Structural Members* — Integrated Truss** — (Optional) — Pre-Fabricated light gauge integrated truss system consisting of a cold-formed, galvanized steel cord and web sections. As per manufacturer's requirements the Integrated Trusses are to be used as prefabricated sections of wall panels and connected together with bolts, nuts and washers to minimum 3-1/2 in. x 3-1/2 in. x 1/8 in. HSS tube steel. Integrated Trusses are 18" deep -min. 18 ga. material, used to support light gauge truss members (Item 2) at their ends.

PRESCIENTCO INC — Pre-fabricated Light Gauge Steel Truss System

1A. **Structural Members* — Integrated Truss HHS Steel Post** — (Optional) — As part of Item 1, minimum 3 1/2" x 3 1/2" x 1/8" HHS tube steel post that may be continuous from UL Fire Rated Wall Assembly W428.

PRESCIENTCO INC — Pre-fabricated Light Gauge Steel Truss System

1B. **Steel Beam** — Not Shown — (Optional) — In lieu of Item 1, W10x22 (fy=50 ksi) min size, used to support structural steel members (Item 2) at their ends.

2. **Structural Members*** — Pre-Fabricated light gauge truss system consisting of a cold-formed, galvanized steel cord and web sections. Trusses are 18" deep -min. 18 ga. material, spaced at max. 24" o.c. and connected to supporting structure as per manufacturer's instructions.

PRESCIENTCO INC — Pre-fabricated Light Gauge Steel Truss System

2A. **Structural Members*** — (In lieu of Item 2. Limited to maximum 1-1/2 Hr ratings.) — Pre-Fabricated light gauge truss system consisting of a cold-formed, galvanized steel cord and web sections. Trusses are 10" deep -min. 18 ga. material, spaced at max. 24" o.c. and connected to supporting structure as per manufacturer's instructions. When pre-fabricated trusses less than 18 inch deep are used the supporting beam when used shall be as per above Item 1B.

PRESCIENTCO INC — Pre-fabricated Light Gauge Steel Truss System

3. **Bridging** — (Not Shown) — Lateral bracing required at the truss bottom node that is closest to the truss supports, lateral bracing installed as per truss manufacturer's instructions. Additional lateral bracing maybe required as per truss manufacturer's instruction.

4. **Flooring Systems** — The following system shall consist of one of the following:

System No. 1

Flooring System* — Mineral and Fiber Boards — Nom 1 in. thick, with long edges tongue and grooved. Long dimension of panels to be perpendicular to Structural members (Item 2) with end joints staggered a min of 2 ft. and centered over the joists. Panels secured to steel joists with 2-1/2 in. long No. 8 self-drilling, self-countersinking steel screws or 1 7/8 in. long power pin spaced a max of 8 in. OC in the field and 4 in. OC on the perimeter with a screw located 3/4 in. from each edge of the panel. In the tongue and groove joints between the Mineral and Fiber Boards a bead of UL Certified Low Pressure Polyurethane Foam adhesive with a maximum Flame Spread Index of 5 and Smoke Developed of 0 may be used. The adhesive can only be used when a Floor Topping Mixture is placed over the Mineral and Fiber Boards.

PLYCEM CONSTRUSISTEMAS HONDURAS S A DE C V — Types Plycem, Plycem-Fibrolit

THE PLYCEM COMPANY INC — Types Plycem, Plycem-Fibrolit

Coatings, General Purpose* — (Optional) - Not Shown - Type ASC-X General Purpose Coating (Refer to BNEV in UL's Building Materials Directory) applied over the Flooring System at a maximum thickness of 48 mils (3 gallons/100 ft²) to partially or fully cover the Flooring System. When Coating is used the Fire Resistance Rating shall be limited to 1 hr. and a Floor Topping Mixture shall be required.

AMERICAN STANDARD COATING LLC — General purpose coating designated as "ASCX".

Floor Topping Mixture* — (Optional) — Min 3/4 in. thickness of floor topping mixture having a minimum compressive strength of 1800 psi. Refer to manufacturer's instructions accompanying the material for specific mix design.

UNITED STATES GYPSUM CO — Types LRK, HSLRK, CSD

USG MEXICO S A DE C V — Types LRK, HSLRK, CSD

Floor Mat Materials* — Not Shown — (Optional) — Floor mat material loose laid over the subfloor. Refer to manufacturer's instructions regarding the minimum thickness of floor topping over each floor mat material.

UNITED STATES GYPSUM CO — Types SAM, LEVELROCK® Brand Sound Reduction Board, LEVELROCK® Brand Floor Underlayment SRM-25

System No. 2

Steel Deck* — PRESCIENT STEEL DECKING Min 1-1/4 in. deep, min 20 MSG galv corrugated steel deck. Attached to each Structural Member Item 2 and/or the supporting structure at 5 in. OC with #10 by 7/8 inch long self-tapping screws or equivalent power actuated fasteners. Fasteners spaced at 5 in OC max. Minimum side joints overlaps shall be 3/4 inch and connected together with at max. 12 inches OC with #10 by 7/8 inch long self-tapping screws or equivalent power actuated fasteners. Minimum bearing of deck at the ends of shall be 3/4 inches and an overlap at the ends is not required.

PRESCIENTCO INC — PRESCIENT STEEL DECKING

Coatings, General Purpose* — (Optional) - Not Shown - Type ASC-X General Purpose Coating (Refer to BNEV in UL's Building Materials Directory) applied over the Flooring System at a maximum thickness of 48 mils (3 gallons/100 ft²) to partially or fully cover the Flooring System. When Coating is used the Fire Resistance Rating shall be limited to 1 hr. and a Floor Topping Mixture shall be required.

AMERICAN STANDARD COATING LLC — General purpose coating designated as "ASCX".

Floor Topping Mixture* — Compressive strength to be 2000 psi min. Minimum thickness to be 1 in. as measured from the top plane of the deck or the top plane of the **Floor Mat Material***. Refer to manufacturer's instructions accompanying the material for specific mix design.

MAXXON CORP — Types Maxxon Standard and Maxxon High Strength

Floor Mat Materials* — (Optional) — Not Shown — Floor mat material loose laid over the top surface of the steel deck. **Floor Topping Mixture*** applied to top surface of steel deck prior to the application of the **Floor Mat Materials***.

MAXXON CORP — Type Encapsulated Sound Mat.

Floor Mat Reinforcement — (Optional) - Refer to manufacturer's instructions regarding minimum thickness of floor topping for use with floor mat reinforcement.

Metal Lath — (Optional) — 3/8 in. expanded galvanized steel diamond mesh, 3.4 lbs/sq yd loose laid over the floor mat material. **Fiber Glass Reinforcement** — (Optional, Not Shown) - 0.015 in. thick PVC coated non-woven fiberglass mesh, 0.368 lbs/sq yd loose laid over the floor mat material.

System No. 3

Flooring System* — Mineral and Fiber Boards — Nom 1 in. thick, with long edges tongue and grooved. Long dimension of panels to be perpendicular to Structural members (Item 2) with end joints staggered a min of 2 ft. and centered over the joists. Panels secured to steel joists with 2-1/2 in. long No. 8 self-drilling, self-countersinking steel screws or 1 7/8 in. long power pin spaced a max

of 8 in. OC in the field and 4 in. OC on the perimeter with a screw located 3/4 in. from each edge of the panel. In the tongue and groove joints between the Mineral and Fiber Boards a bead of UL Certified Low Pressure Polyurethane Foam adhesive with a maximum Flame Spread Index of 5 and Smoke Developed of 0 may be used. The adhesive can only be used when a Floor Topping Mixture is placed over the Mineral and Fiber Boards.

PLYCEM CONSTRUSISTEMAS HONDURAS S A DE C V — Types Plycem, Plycem-Fibrolit

THE PLYCEM COMPANY INC — Types Plycem, Plycem-Fibrolit

Coatings, General Purpose* — (Optional) - Not Shown - Type ASC-X General Purpose Coating (Refer to BNEV in UL's Building Materials Directory) applied over the Flooring System at a maximum thickness of 48 mils (3 gallons/100 ft²) to partially or fully cover the Flooring System. When Coating is used the Fire Resistance Rating shall be limited to 1 hr. and a Floor Topping Mixture shall be required.

AMERICAN STANDARD COATING LLC — General purpose coating designated as "ASCX".

Floor Topping Mixture* — (Optional) - Compressive strength to be 1800 psi min. Minimum thickness to be 3/4 in. as measured from the top plane of the deck. Refer to manufacturer's instructions accompanying the material for specific mix design.

MAXXON CORP — Types Maxxon Standard and Maxxon High Strength

Floor Mat Materials* — (Optional) — Not Shown — Floor mat material loose laid over the crests of the steel deck. Flutes of the steel deck to be filled with **Floor Topping Mixture*** prior to the application of the **Floor Mat Materials***.

MAXXON CORP — Type Encapsulated Sound Mat.

Floor Mat Reinforcement — (Optional) - Refer to manufacturer's instructions regarding minimum thickness of floor topping for use with floor mat reinforcement.

Metal Lath — (Optional) — 3/8 in. expanded galvanized steel diamond mesh, 3.4 lbs/sq yd loose laid over the floor mat material. **Fiber Glass Reinforcement** — (Optional, Not Shown) - 0.015 in. thick PVC coated non-woven fiberglass mesh, 0.368 lbs/sq yd loose laid over the floor mat material.

System No. 4

Flooring System* — Mineral and Fiber Boards — — Nom 1 in. thick, with long edges tongue and grooved. Long dimension of panels to be perpendicular to Structural members (Item 2) with end joints staggered a min of 2 ft. and centered over the joists. Panels secured to steel joists with 2-1/2 in. long No. 8 self-drilling, self-countersinking steel screws or 1 7/8 in. long power pin spaced a max of 8 in. OC in the field and 4 in. OC on the perimeter with a screw located 3/4 in. from each edge of the panel. In the tongue and groove joints between the Mineral and Fiber Boards a bead of UL Certified Low Pressure Polyurethane Foam adhesive with a maximum Flame Spread Index of 5 and Smoke Developed of 0 may be used. The adhesive can only be used when a Floor Topping Mixture is placed over the Mineral and Fiber Boards.

PLYCEM CONSTRUSISTEMAS HONDURAS S A DE C V — Types Plycem, Plycem-Fibrolit

THE PLYCEM COMPANY INC — Types Plycem, Plycem-Fibrolit

Coatings, General Purpose* — (Optional) - Not Shown - Type ASC-X General Purpose Coating (Refer to BNEV in UL's Building Materials Directory) applied over the Flooring System at a maximum thickness of 48 mils (3 gallons/100 ft²) to partially or fully cover the Flooring System. When Coating is used the Fire Resistance Rating shall be limited to 1 hr. and a Floor Topping Mixture shall be required.

AMERICAN STANDARD COATING LLC — General purpose coating designated as "ASCX".

Floor Topping Mixture* — (Optional) — Min 3/4 in. thickness of floor topping mixture having a minimum compressive strength of 1800 psi. Refer to manufacturer's instructions accompanying the material for specific mix design.

ARCOSA SPECIALTY MATERIALS — AccuCrete® Types NexGen, Green, Prime and PrePour, AccuRadiant®, AccuLevel® Types G40, G50 and SD30

DEPENDABLE LLC — GSL M3.4, GSL K2.6, GSL-CSD or GSL RH

Floor Mat Materials* — Not Shown — (Optional) — Floor mat material loose laid over the subfloor. Refer to manufacturer's instructions regarding the minimum thickness of floor topping over each floor mat material.

ARCOSA SPECIALTY MATERIALS — AccuQuiet types D13, D-18, D25, DX38, EM.125, EM.125S, EM.250, EM.250S, EM.375, EM.375S, EM.750, and EM.750S.

KEENE BUILDING PRODUCTS CO INC — Quiet Qurl 55/025, Quiet Qurl 55/025 N, Quiet Qurl 55/025 MT, Quiet Qurl 55/025 N MT, Quiet Qurl 60/040, Quiet Qurl 60/040 N, Quiet Qurl 65/075, Quiet Qurl 65/075 N, Quiet Qurl 52/103, and Quiet Qurl 52/103N

System No. 5

Steel Deck* — PRESCIENT STEEL DECKING Min 1-1/4 in. deep, min 20 MSG galv corrugated steel deck. Attached to each Structural Member Item 2 and/or the supporting structure at 5 in. OC with #10 by 7/8 inch long self-tapping screws or equivalent power actuated fasteners. Fasteners spaced at 5 in OC max. Minimum side joints overlaps shall be 3/4 inch and connected together with at max. 12 inches OC with #10 by 7/8 inch long self-tapping screws or equivalent power actuated fasteners. Minimum bearing of deck at the ends of shall be 3/4 inches and an overlap at the ends is not required.

PRESCIENTCO INC — PRESCIENT STEEL DECKING

Coatings, General Purpose* — (Optional) - Not Shown - Type ASC-X General Purpose Coating (Refer to BNEV in UL's Building Materials Directory) applied over the Flooring System at a maximum thickness of 48 mils (3 gallons/100 ft²) to partially or fully cover the Flooring System. When Coating is used the Fire Resistance Rating shall be limited to 1 hr. and a Floor Topping Mixture shall be required.

AMERICAN STANDARD COATING LLC — General purpose coating designated as "ASCX".

Floor Topping Mixture* — Compressive strength to be 2000 psi min. Minimum thickness to be 1 in. as measured from the top plane of the deck or the top plane of the **Floor Mat Material***. Refer to manufacturer's instructions accompanying the material for specific mix design.

ARCOSA SPECIALTY MATERIALS — Accu-Crete, AccuRadiant, AccuLevel G40 and AccuLevel SD30

DEPENDABLE LLC — GSL M3.4, GSL K2.6, GSL-CSD or GSL RH

Floor Mat Materials* — (Optional) — Not Shown — Floor mat material loose laid over the crests of the steel deck. Flutes of the steel deck to be filled with **Floor Topping Mixture*** prior to the application of the **Floor Mat Materials***.

ARCOSA SPECIALTY MATERIALS — AccuQuiet D13, Type AccuQuiet D-18, Type AccuQuiet D25 and Type AccuQuiet DX38

KEENE BUILDING PRODUCTS CO INC — Quiet Qurl 55/025, Quiet Qurl 55/025 N, Quiet Qurl 55/025 MT, Quiet Qurl 55/025 N MT, Quiet Qurl 60/040, Quiet Qurl 60/040 N, Quiet Qurl 65/075, Quiet Qurl 65/075 N, Quiet Qurl 52/103, and Quiet Qurl 52/103N

System No. 6 (Limited to max 1 Hr unrestrained assembly ratings.)

Subflooring — Min 3/4 in. thick plywood with exterior glue, conforming to PS 1-83, min grade "Standard". Face grain of plywood to be perpendicular to the trusses with joints staggered.

Vapor Barrier — (Optional) - Commercial asphalt saturated felt, 0.010 in. thick.

Finish Flooring - Floor Topping Mixture* — (Optional) - Min 3/4 in. thickness of floor topping mixture having a minimum compressive strength of 1800 psi. Refer to manufacturer's instructions accompanying the material for specific mix design.

UNITED STATES GYPSUM CO — Types LRK, HSLRK, CSD

USG MEXICO S A DE C V — Types LRK, HSLRK, CSD

Coatings, General Purpose* — (Optional) - Not Shown - Type ASC-X General Purpose Coating (Refer to BNEV in UL's Building Materials Directory) applied over the Flooring System at a maximum thickness of 48 mils (3 gallons/100 ft²) to partially or fully cover the Flooring System. When Coating is used the Fire Resistance Rating shall be limited to 1 hr. and a Floor Topping Mixture shall be required.

AMERICAN STANDARD COATING LLC — General purpose coating designated as "ASCX".

Floor Mat Materials* — (Optional) - Floor mat material loose laid over the subfloor. Refer to manufacturer's instructions regarding the minimum thickness of floor topping over each floor mat material.

UNITED STATES GYPSUM CO — Types SAM, LEVELROCK® Brand Sound Reduction Board, LEVELROCK® Brand Floor Underlayment SRM-25

Alternate Floor Mat Materials* — (Optional) - Nom 3/8 in. thick floor mat material loose laid over the subfloor. Floor topping thickness shall be as specified under Floor Topping Mixture.

GRASSWORX L L C — Type SC50

System No. 7

Flooring System* — Mineral and Fiber Boards — Nom 1 in. thick, with long edges tongue and grooved. Long dimension of panels to be perpendicular to Structural members (Item 2) with end joints staggered a min of 2 ft. and centered over the joists. Panels secured to steel joists with 2-1/2 in. long No. 8 self-drilling, self-countersinking steel screws or 1 7/8 in. long power pin spaced a max of 8 in. OC in the field and 4 in. OC on the perimeter with a screw located 3/4 in. from each edge of the panel. In the tongue and groove joints between the Mineral and Fiber Boards a bead of UL Certified Low Pressure Polyurethane Foam adhesive with a maximum Flame Spread Index of 5 and Smoke Developed of 0 may be used. The adhesive can only be used when a Floor Topping Mixture is placed over the Mineral and Fiber Boards.

PLYCEM CONSTRUSISTEMAS HONDURAS S A DE C V — Types Plycem, Plycem-Fibrolit

THE PLYCEM COMPANY INC — Types Plycem, Plycem-Fibrolit

Coatings, General Purpose* — (Optional) - Not Shown - Type ASC-X General Purpose Coating (Refer to BNEV in UL's Building Materials Directory) applied over the Flooring System at a maximum thickness of 48 mils (3 gallons/100 ft²) to partially or fully cover the Flooring System. When Coating is used the Fire Resistance Rating shall be limited to 1 hr. and a Floor Topping Mixture shall be required.

AMERICAN STANDARD COATING LLC — General purpose coating designated as "ASCX".

Floor Topping Mixture* — (Optional) — Min 3/4 in. thickness of floor topping mixture having a minimum compressive strength of 1800 psi. Refer to manufacturer's instructions accompanying the material for specific mix design.

FORMULATED MATERIALS LLC — Types FR-25, FR-30, and SiteMix.

Floor Mat Materials* — (Optional, Not Shown) — Floor mat material loose laid over the subfloor. Prior to placing floor topping mixture, optional self-adhering waterproof membrane or fabric can be installed on the flooring system. Refer to manufacturer's instructions regarding the minimum thickness of floor topping over each floor mat material.

FORMULATED MATERIALS LLC — Types M1, M2, M3, Elite, Duo, R1, and R2.

System No. 8

Steel Deck* — PRESCIENT STEEL DECKING Min 1-1/4 in. deep, min 20 MSG galv corrugated steel deck. Attached to each Structural Member Item 2 and/or the supporting structure at 5 in. OC with #10 by 7/8 inch long self-tapping screws or equivalent power actuated fasteners. Fasteners spaced at 5 in OC max. Minimum side joints overlaps shall be 3/4 inch and connected together with at max. 12 inches OC with #10 by 7/8 inch long self-tapping screws or equivalent power actuated fasteners. Minimum bearing of deck at the ends of shall be 3/4 inches and an overlap at the ends is not required.

PRESCIENTCO INC — PRESCIENT STEEL DECKING

Coatings, General Purpose* — (Optional) - Not Shown - Type ASC-X General Purpose Coating (Refer to BNEV in UL's Building Materials Directory) applied over the Flooring System at a maximum thickness of 48 mils (3 gallons/100 ft²) to partially or fully cover the Flooring System. When Coating is used the Fire Resistance Rating shall be limited to 1 hr. and a Floor Topping Mixture shall be required.

AMERICAN STANDARD COATING LLC — General purpose coating designated as "ASCX".

Floor Topping Mixture* — Compressive strength to be 2000 psi min. Minimum thickness to be 1 in. as measured from the top plane of the deck or the top plane of the **Floor Mat Material***. Refer to manufacturer's instructions accompanying the material for specific mix design.

FORMULATED MATERIALS LLC — Types FR-25, FR-30, and SiteMix.

Floor Mat Materials* — (Optional, Not Shown) — Floor mat material loose laid over the crests of the steel deck. *. Prior to placing floor topping mixture, optional self-adhering waterproof membrane or fabric can be installed on the steel decking.

FORMULATED MATERIALS LLC — Types M1, M2, M3, Elite, Duo, R1, and R2.

System No. 9

Steel Deck* — PRESCIENT STEEL DECKING Min 1-1/4 in. deep, min 20 MSG galv corrugated steel deck. Attached to each Structural Member Item 2 and/or the supporting structure at 5 in. OC with #10 by 7/8 inch long self- tapping screws or equivalent power actuated fasteners. Fasteners spaced at 5 in OC max. Minimum side joints overlaps shall be 3/4 inch and connected together with at max. 12 inches OC with #10 by 7/8 inch long self- tapping screws or equivalent power actuated fasteners. Minimum bearing of deck at the ends of shall be 3/4 inches and an overlap at the ends is not required.

PRESCIENTCO INC — PRESCIENT STEEL DECKING

Coatings, General Purpose* — (Optional) - Not Shown - Type ASC-X General Purpose Coating (Refer to BNEV in UL's Building Materials Directory) applied over the Flooring System at a maximum thickness of 48 mils (3 gallons/100 ft²) to partially or fully cover the Flooring System. When Coating is used the Fire Resistance Rating shall be limited to 1 hr. and a Floor Topping Mixture shall be required.

AMERICAN STANDARD COATING LLC — General purpose coating designated as "ASCX".

Floor Topping Mixture* — Min 1 in. thickness of floor topping mixture having a minimum compressive strength of 1800 psi. Refer to manufacturer's instructions accompanying the material for specific mix design.

UNITED STATES GYPSUM CO — Types LRK, HSLRK, CSD

USG MEXICO S A DE C V — Types LRK, HSLRK, CSD

System No. 10

Steel Deck* — PRESCIENT STEEL DECKING Min 1-1/4 in. deep, min 20 MSG galv corrugated steel deck. Attached to each Structural Member Item 2 and/or the supporting structure at 5 in. OC with #10 by 7/8 inch long self- tapping screws or equivalent power actuated fasteners. Fasteners spaced at 5 in OC max. Minimum side joints overlaps shall be 3/4 inch and connected together with at max. 12 inches OC with #10 by 7/8 inch long self- tapping screws or equivalent power actuated fasteners.

Minimum bearing of deck at the ends of shall be 3/4 inches and an overlap at the ends is not required.

PRESCIENTCO INC — PRESCIENT STEEL DECKING

Flooring System* — Mineral and Fiber Boards — Nom 1 in. thick, with long edges tongue and grooved. Panels secured to Steel Deck crest with 1-1/2 in. long No. 8 self-drilling, self-countersinking steel screws or 1 7/8 in. long power pin spaced a max of 24 in. OC in the field in both directions and 2 in. from each edge and sides of the panel. In the tongue and groove joints between the Mineral and Fiber Boards a bead of UL Certified Low Pressure Polyurethane Foam adhesive with a maximum Flame Spread Index of 5 and Smoke Developed of 0 maybe used. The adhesive can only be used when a Floor Topping Mixture is placed over the Mineral and Fiber Boards.

PLYCEM CONSTRUSISTEMAS HONDURAS S A DE C V — Types Plycem, Plycem-Fibrolit

THE PLYCEM COMPANY INC — Types Plycem, Plycem-Fibrolit

Alternate Flooring System — Building Units* — Not Shown - As an alternate to Mineral and Fiber Boards. For 1 hour use only. Nom 3/4 in. thick, tongue and grooved boards. Long dimension of boards to be perpendicular to joists with end joints staggered a min of 4 ft. and centered over the joists. Boards secured to steel joists through steel deck with 1-1/2 in. long self-drilling, self-countersinking, bugle head steel screws spaced a max of 12 in. OC in the field with screws located 1 in. from long edge, and max 8 in. OC along the end joints with screws located 1/2 in. from end joint.

ECTEK INTERNATIONAL INC — Type MegaBoard

Coatings, General Purpose* — (Optional) - Not Shown - Type ASC-X General Purpose Coating (Refer to BNEV in UL's Building Materials Directory) applied over the Flooring System at a maximum thickness of 48 mils (3 gallons/100 ft²) to partially or fully cover the Flooring System. When Coating is used the Fire Resistance Rating shall be limited to 1 hr. and any Floor Topping system specified in one of the Floor Systems 1, 3, 4 and 7 shall be required.

AMERICAN STANDARD COATING LLC — General purpose coating designated as "ASCX".

System No. 11

Steel Deck* — PRESCIENT STEEL DECKING Min 1-1/4 in. deep, min 20 MSG galv corrugated steel deck. Attached to each Structural Member Item 2 and/or the supporting structure at 5 in. OC with #10 by 7/8 inch long self- tapping screws or equivalent power actuated fasteners. Fasteners spaced at 5 in OC max. Minimum side joints overlaps shall be 3/4 inch and connected together with at max. 12 inches OC with #10 by 7/8 inch long self- tapping screws or equivalent power actuated fasteners. Minimum bearing of deck at the ends of shall be 3/4 inches and an overlap at the ends is not required.

PRESCIENTCO INC — PRESCIENT STEEL DECKING

Coatings, General Purpose* — (Optional) - Not Shown - Type ASC-X General Purpose Coating (Refer to BNEV in UL's Building Materials Directory) applied over the Flooring System at a maximum thickness of 48 mils (3 gallons/100 ft²) to partially or fully cover the Flooring System. When Coating is used the Fire Resistance Rating shall be limited to 1 hr. and a Floor Topping Mixture shall be required.

AMERICAN STANDARD COATING LLC — General purpose coating designated as "ASCX".

Floor Topping Mixture* — Compressive strength to be 3500 psi min. Minimum thickness to be 1 in. as measured from the top plane of the deck or the top plane of the **Floor Mat Material***. Refer to manufacturer's instructions accompanying the material for specific mix design. An ethylene vinyl acetate adhesive may be applied to the steel deck prior to the installation of the floor topping mixture at a maximum application rate of 0.025 lbs./ft².

HACKER INDUSTRIES INC — Firm-Fill CMD

Floor Mat Materials* — (Optional) — Not Shown — All Floor mat materials loose laid over the crests of the steel deck. Flutes of the steel deck to be filled with **Floor Topping Mixture*** prior to the application of the **Floor Mat Materials***.

Floor mat material nom 1/4 in. (6 mm) thick. Floor topping thickness shall be a min of 1 in. (25 mm)

HACKER INDUSTRIES INC — FIRM-FILL SCM 125

Alternate Floor Mat Materials — (Optional) — Floor mat material nom 1/4 in. (6 mm) thick. Floor topping thickness shall be a min of 1 in. (25 mm)

HACKER INDUSTRIES INC — Type FIRM-FILL SCM 250

Alternate Floor Mat Materials — (Optional) — Floor mat material nom 3/8 in. (10 mm) thick. Floor topping thickness shall be a min of 1-1/4 in. (32 mm)

HACKER INDUSTRIES INC — FIRM-FILL SCM 400

Alternate Floor Mat Materials — (Optional) — Floor mat material nom 3/4 in. (19 mm) thick. Floor topping thickness shall be a min of 1-1/2 in. (38mm)

HACKER INDUSTRIES INC — FIRM-FILL SCM 750

System No. 12

Flooring System* — Mineral and Fiber Boards — Nom 1 in. thick, with long edges tongue and grooved. Long dimension of panels to be perpendicular to Structural members (Item 2) with end joints staggered a min of 2 ft. and centered over the joists. Panels secured to steel joists with 2-1/2 in. long No. 8 self-drilling, self-countersinking steel screws or 1 7/8 in. long power pin spaced a max of 8 in. OC in the field and 4 in. OC on the perimeter with a screw located 3/4 in. from each edge of the panel. In the tongue and groove joints between the Mineral and Fiber Boards a bead of UL Certified Low Pressure Polyurethane Foam adhesive with a maximum Flame Spread Index of 5 and Smoke Developed of 0 may be used. The adhesive can only be used when a Floor Topping Mixture is placed over the Mineral and Fiber Boards.

PLYCEM CONSTRUSISTEMAS HONDURAS S A DE C V — Types Plycem, Plycem-Fibrolit.

THE PLYCEM COMPANY INC — Types Plycem, Plycem-Fibrolit.

Coatings, General Purpose* — (Optional) - Not Shown - Type ASC-X General Purpose Coating (Refer to BNEV in UL's Building Materials Directory) applied over the Flooring System at a maximum thickness of 48 mils (3 gallons/100 ft²) to partially or fully cover the Flooring System. When Coating is used the Fire Resistance Rating shall be limited to 1 hr. and a Floor Topping Mixture shall be required.

AMERICAN STANDARD COATING LLC — General purpose coating designated as "ASCX".

Floor Topping Mixture* — (Optional) — Min 3/4 in. thickness of floor topping mixture having a minimum compressive strength of 1800 psi. Refer to manufacturer's instructions accompanying the material for specific mix design.

HACKER INDUSTRIES INC — Firm-Fill CMD.

Floor Mat Materials* — Not Shown — (Optional) — Floor mat material loose laid over the subfloor. Refer to manufacturer's instructions regarding the minimum thickness of floor topping over each floor mat material.

HACKER INDUSTRIES INC — FIRM-FILL SCM 125, Firm-Fill SCM 250, Firm-Fill SCM 400, Firm-Fill SCM 750.

System No. 13

Flooring System* — Mineral and Fiber Boards — Nom 1 in. thick, with long edges tongue and grooved. Long dimension of panels to be perpendicular to Structural members (Item 2) with end joints staggered a min of 2 ft. and centered over the joists. Panels secured to steel joists with 2-1/2 in. long No. 8 self-drilling, self-countersinking steel screws or 1-7/8 in. long power pin spaced a max of 8 in. OC in the field and 4 in. OC on the perimeter with a screw located 3/4 in. from each edge of the panel. In the tongue and groove joints between the Mineral and Fiber Boards a bead of UL Certified Low Pressure Polyurethane Foam adhesive with a maximum Flame Spread Index of 5 and Smoke Developed of 0 may be used. The adhesive can only be used when a Floor Topping Mixture is placed over the Mineral and Fiber Boards.

PLYCEM CONSTRUSISTEMAS HONDURAS S A DE C V — Types Plycem, Plycem-Fibrolit

THE PLYCEM COMPANY INC — Types Plycem, Plycem-Fibrolit

Coatings, General Purpose* — (Optional) - Not Shown - Type ASC-X General Purpose Coating (Refer to BNEV in UL's Building Materials Directory) applied over the Flooring System at a maximum thickness of 48 mils (3 gallons/100 ft²) to partially or fully cover the Flooring System. When Coating is used the Fire Resistance Rating shall be limited to 1 hr. and a Floor Topping Mixture shall be required.

AMERICAN STANDARD COATING LLC — General purpose coating designated as "ASCX".

Vapor Barrier — (Optional) - Commercial asphalt saturated felt, 0.030 in. thick.

Vapor Barrier — (Optional) - Nom 0.010 in. thick commercial rosin-sized building paper

Finish Flooring - Floor Topping Mixture* — Min 3/4 in. thickness of any Floor Topping Mixture bearing the UL Classification Marking as to Fire Resistance. See Floor- and Roof-Topping Mixtures (CCOX) category for names of Classified Companies.

Floor Mat Materials* — (Optional, Not Shown) - Floor mat material loose laid over the subfloor. Refer to manufacturer's instructions regarding the minimum thickness of floor topping over each floor mat material.

LOW & BONAR INC — EnkaSonic® by Colbond a member of the Low & Bonar group Types 125, 250, 250 Plus, 400, 400 Plus, 750, and 750 Plus.

Floor Mat Reinforcement — (Optional) - Refer to manufacturer's instructions regarding minimum thickness of floor topping for use with floor mat reinforcement.

Metal Lath — (Optional) — Expanded steel diamond mesh, 2.5 lb / sq yd loose laid over floor mat material.

Fiberglass Mesh Reinforcement — (Optional) — Coated non-woven glass fiber mesh grid loose laid over floor mat material.

5. **Flexible Air Duct*** — (Optional) — Bearing the UL Listing Mark — Any UL Class 0 or Class 1, flexible air duct, nom maximum 10 in. diam. for use with Item 6. Constructed with a steel wire helix, encapsulated in a 2-ply, air tight inner core, with minimum R6 fiberglass insulation and a polyethylene vapor barrier surround. Flexible air duct attached to damper box sleeve with adjustable hose clamp as per manufacturer's instructions. When the duct is used with Item 7A and 8A it shall be kept off the Gypsum Board Item 9 by a minimum of 4 inches.

5A. **Rigid Air Duct*** — (Optional) (In lieu of Item 5) — Bearing the UL Listing Mark — Any UL rigid air duct classified to UL Standard 181, nom maximum 10 in. diam. for use with Item 6. Air duct attached to damper box sleeve with adjustable hose clamp as per manufacturer's instructions. Duct shall be insulated with minimum R6 fiberglass insulation. Fiberglass insulation on duct bearing the UL Classification Marking for Surface Burning Characteristics, having a flame spread value of 25 or less and a smoke value of 50 or less. When the duct is used with Item 7A and 8A it shall be kept off the Gypsum Board Item 9 by a minimum of 4 inches.

5B. **Rigid Air Duct*** — (Optional) (In lieu of Item 5) — Bearing the UL Listing Mark — Any UL rigid rectangular air duct classified to UL Standard 181, nom maximum 10 in. deep by 18 in. wide, for use with Item 6. Air duct shall run parallel to trusses, and be protected with minimum R6 mineral fiber blanket insulation bearing the UL Classification Marking for Surface Burning Characteristics, having a flame spread value of 25 or less and a smoke value of 50 or less. Flexible air duct attached to damper box sleeve with adjustable hose clamp as per manufacturer's instructions. When the duct is used with Item 7A and 8A it shall be kept off the Gypsum Board Item 9 by a minimum of 4 inches.

6. **Ceiling Damper*** — (For use with Item 5 or Item 5A) — Max damper assembly size nom 18-1/2 in. long by 16 in. wide and 16 in. high, fabricated from galv. steel. Aggregate damper openings shall not exceed 94 sq. in. per 100 sq. ft. of ceiling area. Damper installed in accordance with the manufacturer's installation instructions provided with the damper.

RUSKIN COMPANY — Model CFD7T, CFD7T-END-BT, CFD7T-90-BT, CFD7T-ST-BT, CFD7T-SB or CFD7T-R6-DB, CFD7T-IB6

6A. **Alternate Ceiling Damper *** — Max 12 in. diameter damper within max 15 in. by 15 in. register box with max 12 in. by 12 in. register opening fabricated from galvanized steel. Aggregate area of the register opening(s) through the ceiling membrane shall not exceed 72 sq. in. per 100 sq. ft. of ceiling area. Damper assembly installed in accordance with the manufacturer's installation instructions.

RUSKIN COMPANY — Model CFD7T-SR

7. **Resilient Channels** — Minimum 25 GA galvanized steel, 1/2 in. deep, 2 in., 2-1/2 in. or 2-5/8 in. wide. Channels shall be spaced maximum 12 in. apart and attached perpendicularly to the bottom flange of each Structural Member (Items 2 or 2A) with one 7/16 in. long wafer head self-drilling, self-tapping #7 steel screw. At locations where gypsum board end joints occur, additional resilient channels shall be installed to provide screw attachments for the gypsum board ends. These

additional channels shall be positioned so that the distance from the end of the board to the center of the first channel is 3 in. and from the board end to the center of the next channel is 12 in.

7A. Resilient Channels — (In lieu of Item 7) (For 1 hr rating) — To be used with Item 8A and Floor System Nos. 2, 5, 8, 9 and 11. Minimum 25 GA galvanized steel, 1/2 in. deep, 2-1/2 in. wide. Channels shall be spaced maximum 16 in. apart and attached to the bottom flange of each Structural Member (Item 2) with one 7/16 in. long wafer head self-drilling, self-tapping #7 steel screw. At locations where gypsum board end joints occur, additional resilient channels shall be installed to provide screw attachments for the gypsum board ends. These additional channels shall be positioned so that the distance from the end of the board to the center of the first channel is 3 in. and from the board end to the center of the next channel is 12 in.

7B. Framing Members* — (Optional, Not Shown) — As an alternate to Item 7 — Furring channels and Framing Members as described below:

a. **Furring channels** — Formed of No. 25 MSG galv steel, 2-3/8 in. wide by 7/8 in. deep, spaced 12 in. OC, perpendicular to trusses. Channel secured to trusses as described in Item b. Ends of adjoining channels overlapped 6 in. and tied together with double strand of No. 18 SWG galv steel wire near each end of overlap. Two channels, spaced 6 in. OC, oriented opposite each gypsum board end joint as shown in end joint detail. Additional channels shall extend min 6 in. beyond each side edge of board.

b. **Framing Members*** — Used to attach furring channels (Item a) to trusses (Item 2). Clips spaced 48 in. OC and secured to the bottom chord of trusses with min 1-5/8 in. long No. 8 self-drilling, self-tapping, bugle, flat or hex head screw through the center grommet. Furring channels are friction fitted into clips. Additional clips required to hold furring channel that supports the gypsum board butt joints.

PLITEQ INC — Type Genie Clip

7C. Steel Framing Members* — (Optional, Not Shown) — As an alternate to Item 7.

a. **Furring Channels** — Formed of No. 25 MSG galv steel, nominal 2-1/2 in. wide by 7/8 in. deep, spaced 12 in. OC, perpendicular to trusses. Channels secured to Cold Rolled Channels at every intersection with a 3/4 in. TEK screw through each furring channel leg. Ends of adjoining channels overlapped 12 in. and fastened together with two double strand No. 18 SWG galv steel wire ties, one at each end of overlap, or with two 3/4 in. TEK screws in each leg of the overlap section. Two furring channels used at end joints of gypsum board (Item 9), each extending a min of 6 in. beyond both side edges of the board.

b. **Cold Rolled Channels** — 1-1/2 in. by 1/2 in., formed from No. 16 ga. galv steel, positioned vertically and parallel to trusses, friction-fitted into the channel caddy on the Steel Framing Members (Item 7Cd) and secured with two 3/4 in. TEK screws. Adjoining lengths of cold rolled channels lapped min. 12 in. and secured along bottom legs with four 3/4 in. TEK screws and wire-tied together with two double strand 18 SWG galv steel wire ties, one at each end of overlap.

c. **Blocking** — Where truss design does not permit direct, full contact of the hanger bracket, a piece of nominal 3-5/8" x 20 ga. steel stud (blocking), min. 12 in. long to permit full contact of the hanger bracket, to be secured vertically to the side of the trusses at the top and bottom of the blocking at each Steel Framing Member (Item 7Cd) location minimum 2-1/2 in. screws.

d. **Steel Framing Members*** — Spaced 48 in. OC. max along truss, and secured to the truss on alternating trusses with two, #10 x 1-1/2 in. screws through mounting holes on the hanger bracket.
PAC INTERNATIONAL L L C — Type RSIC-SI-CRC EZ Clip

7D. **Steel Framing Members*** — (Optional, Not Shown) — As an alternate to Item 7.

a. **Furring Channels** — Formed of No. 25 MSG galv steel, nominal 2-1/2 in. wide by 7/8 in. deep, spaced 12 in. OC perpendicular to trusses and friction fit into Steel Framing Members (Item 7Dc). Ends of adjoining channels overlapped 6 in. and tied together with double strand of No. 18 SWG galv steel wire near each end of overlap or with two TEK screws along each leg of the 6 in. overlap. Two furring channels used at end joints of gypsum board (Item 9). Butt joint channels held in place by strong back channels placed upside down, on top of, and running perpendicular to primary furring channels, extending 6 in. longer than length of gypsum side joint. Strong back channels spaced maximum 48 in. OC. Strong back channels secured to every intersection of primary furring channels with four 7/16 in. pan head screws, two along each of the legs at intersections. Butt joint channels run perpendicular to strong back channels and shall be minimum 6 in. longer than length of joint, secured to strong back channels with 7/16 in. pan head screws, two along each of the legs at intersection with strong back channels.

b. **Blocking** — Where truss design does not permit direct, full contact of the hanger bracket, a piece of nominal 3-5/8" x 20 ga. steel stud (blocking), min. 12 in. long to permit full contact of the hanger bracket, to be secured vertically to the side of the trusses at the top and bottom of the blocking at each Steel Framing Member (Item 7Dc) location with 16d nails or minimum 2-1/2 in. screws.

c. **Steel Framing Members*** — Used to attach furring channels (Item 7Da) to trusses. Clips spaced 48 in. OC and secured along truss webs at each furring channel intersection with min. 3/4 in. long self-drilling No. 10-16 TEK screws through each of the provided hole locations. Furring channels are friction fitted into clips.

PAC INTERNATIONAL L L C — Type RSIC-S1-1 Ultra

7E. **Steel Framing Members*** — (Optional, Not Shown) — As an alternate to Item 7.

a. **Furring channels** — Formed of No. 25 MSG galv steel. 2-9/16 in. wide by 7/8 in. deep, spaced 12 in. OC, perpendicular to trusses. Channels secured to trusses as described in Item b. Ends of adjoining channels overlapped 6 in. and tied together with double strand of No. 18 SWG galv steel wire near each end of overlap.

b. **Steel Framing Members*** — Used to attach furring channels (Item a) to the steel trusses (Item 2). Clips spaced a max of 48 in. OC. RSIC-1 clips secured to alternating joists with No. 8 x 1-5/8 in. fine thread screw through the center grommet. Furring channels are friction fitted into clips. RSIC-1 clips for use with 2-9/16 in. wide furring channels. Adjoining channels are overlapped as described in Item a. As an alternate, ends of adjoining channels may be overlapped 6 in. and secured together with two self-tapping No. 6 framing screws, min. 7/16 in. long at the midpoint of the overlap, with one screw on each flange of the channel.

PAC INTERNATIONAL L L C — Type RSIC-1

7F. **Steel Framing Members*** — (Optional, Not Shown) — Used as an alternate method to attach resilient channels (Item 7) to structural members. A resilient sound isolation accessory shall be used at each attachment point of the resilient channels and spaced max 24 in. O.C. Channel ends butted and centered under the structural members and attached with one accessory at each end. Additional

accessories used to hold resilient channels that support the gypsum board end joints, as described in Item 7. The accessory envelops the mounting edge of the resilient channel. The accessory and resilient channel are fastened to the structural members with the screws supplied with the accessory and per the accessory manufacturer's installation instructions. Gypsum board butt joints staggered minimum 24 in. OC when used.

PAC INTERNATIONAL L L C — Types RC-1 Boost

8. **Batts and Blankets*** — Any 3-1/2 in. thickness, minimum density 0.5 lb./ft³, unfaced mineral wool or glass fiber insulation bearing the UL Classification Marking for Surface Burning Characteristics, having a flame spread value of 25 or less and a smoke value of 50 or less. Insulation fitted in the concealed space, draped over the resilient channel/gypsum board ceiling membrane.

8A. **Batts and Blankets*** — (In lieu of Item 8) (For 1 hr rating) To be used with Item 7A and Floor System Nos. 2, 5, 8, 9 and 11. Any 3-1/2 in. thickness, minimum density 0.5 lb./ft³, unfaced mineral wool or glass fiber insulation bearing the UL Classification Marking for Surface Burning Characteristics, having a flame spread value of 25 or less and a smoke value of 50 or less. Insulation attached to the underside of the steel deck with minimum 12 ga. copper coated steel insulation pins stud welded to the underside of the metal deck. The pins shall be a minimum 3/4 inch longer than the thickness of the insulation. The insulation is locked into place over the insulation pins with 2-1/2 inch square self-locking (speed clips) washers. The part of the pins protruding from the washers shall be bent 90 degrees. The pins shall be spaced at a minimum 12 inches OC with additional pins located 2 inches for the sides of the insulation.

9. **Gypsum Board*** — For 1 and 1-1/2 Hr Ratings — One layer of nom 5/8 in. thick by 48 in. wide boards, installed with long dimension parallel to Structural member (Items 2 or 2A). Attached to resilient channels using 1 in. long Type S, #6 bugle-head screws. Screws spaced a max of 8 in. OC in the field. At the butt side joints, screws shall be located 1-1/2 in. and 4 in. from the board edges. For the 2 Hr Ratings — Two layers of nom 5/8 in. thick by 48 in. wide boards, installed with long dimension parallel to Structural member (Item 2). Base layer attached as described above. Face layer attached to the resilient channels using 1-5/8 in. long Type S bugle-head screws spaced 8 in. OC along butted end-joints and 8 in. OC in the field. Screws staggered from base layer screws. Face layer side and end joints offset a minimum 24 in. from base layer side and end joints.

When **Steel Framing Members** (Item 7C) are used, nom 5/8 in. thick, 4 ft wide gypsum board, installed as described in Item 9 as per hourly ratings. Adjacent butt joints staggered minimum 48 in. OC.

When **Steel Framing Members** (Item 7D) are used, nom 5/8 in. thick, 4 ft wide gypsum board, installed as described in Item 9 as per hourly ratings. Butt joints staggered minimum 24 in. OC.

When **Steel Framing Members** (Item 7E) are used (**For 1 and 1-1/2 hour ratings - one layer of board**), gypsum panels installed with long dimensions perpendicular to furring channels. Panels attached to the furring channels using 1 in. long Type S bugle-head steel screws spaced 8 in. OC along butted end joints and 12 in. OC in the field. Butted end joints shall be staggered min. 2 ft within the assembly, and occur midway between the continuous furring channels. Each end of each gypsum panel shall be supported by a single length of furring channel equal to the width of the gypsum panel plus 6 in. on each end. The two support furring channels shall be spaced approximately 3-1/2 in. OC, and be attached with one clip at each end of the channel. (**For 2 hour**

rating - two layers of board), base layer installed as described above. Outer layer attached as described in Item 9.

AMERICAN GYPSUM CO — Type AG-C

CGC INC — Type ULIX

NATIONAL GYPSUM CO — Type eXP-C (limited to 1 hr rating only), FSW-C, FSK-C

UNITED STATES GYPSUM CO — Type C, ULIX

USG BORAL DRYWALL SFZ LLC — Type C

10. **Framing Members*** — (Not Shown) To be used in lieu of Item 7.

a. **Main Runners** — Installed perpendicular to Structural Steel Members (Item 2) — Nom 10 or 12 ft long, 15/16 in. or 1-1/2 in. wide face, spaced 4 ft OC. Main runners hung a min of 2 in. from bottom chord of Structural Steel Members with 12 SWG galv steel wire. Wires located a max of 48 in. OC.

b. **Cross tees or channels** — Nom 4 ft long, 15/16 in. or 1-1/2 in. wide face, or cross channels, nom 4 ft long, 1-1/2 in. wide face, installed perpendicular to the main runners, spaced 16 in. OC. Additional cross tees or channels used at 8 in. from each side of butted wallboard end joints. The cross tees or channels may be riveted or screw-attached to the wall angle or channel to facilitate the ceiling installation.

c. **Wall angles or channels** — Used to support steel framing member ends and for screw-attachment of the gypsum wallboard — Min 0.016 in. thick painted or galvanized steel angle with 1 in. legs or min. 0.016 in. thick painted or galvanized steel channel with a 1 by 1-1/2 by 1 in. profile, attached to walls at perimeter of ceiling with fasteners 16 in. OC.

CGC INC — Type DGL or RX

USG INTERIORS LLC — Type DGL or RX

11. **Gypsum Board*** — For use with Steel Framing Members (Item 10) - **For the 1 hr ratings** - One layer of 5/8 in. thick, 4 ft wide board; installed with long dimension perpendicular to cross tees with side joints centered along main runners and end joints centered along cross tees. Fastened to cross tees with 1 in. long steel wallboard screws spaced 8 in. OC in the field and 8 in. OC along end joints. Fastened to main runners with 1 in. long wallboard screws spaced midway between cross tees. Screws along sides and ends of boards spaced 3/8 to 1/2 in. from board edge. End joints of the sheets shall be staggered with spacing between joints on adjacent boards not less than 4 ft OC. Joints treated as described in Item 9. **For the 2 hr rating** - Two layers of nominal 5/8 in. thick by 48 in. wide

boards. Inner layer installed with long dimension perpendicular to cross tees with side joints centered along main runners and end joints centered along cross tees. Inner layer fastened to cross tees with 1-1/4 in. long Type S bugle-head steel screws spaced 8 in. OC along butted end joints and 12 in. OC in the field of the board. End joints of adjacent wallboard sheets shall be staggered not less than 4 ft OC. Outer layer attached to the cross tees through inner layer using 1-7/8 in. long Type S bugle-head steel screws spaced 8 in. OC at butted end joints and 12 in. OC in the field. Butted end joints to be centered along cross tees and be offset a min of 32 in. from end joints of inner layer. Rows of screws on both sides of butted end joints of each layer shall be located 3/8 to 1/2 in. from end joints. Butted side joints of outler layer to be offset a min of 18 in. from butted side joints of inner layer. Joints treated as described in Item 9.

NATIONAL GYPSUM CO — Types eXP-C (limited to 1 hr rating only), FSW-C, FSK-C

UNITED STATES GYPSUM CO — Type C, IP-X2, IPC-AR

USG BORAL DRYWALL SFZ LLC — Type C

11A. **Gypsum Board*** (As an alternative to Item 11) — Nom 5/8 in. thick, 48 in. wide gypsum board, installed and secured as described in Item 11 with max screw spacing 8 in. OC.

CGC INC — Type ULIX

UNITED STATES GYPSUM CO — ULIX

12. **Finishing System** — (Not Shown) — Vinyl, dry or premixed joint compound, applied in two coats to joints and screw heads; paper tape, 2 in. wide, embedded in first layer of compound over all joints. As an alternate, nom 3/32 in. thick veneer plaster may be applied to the entire surface of gypsum wallboard.

*** Indicates such products shall bear the UL or cUL Certification Mark for jurisdictions employing the UL or cUL Certification (such as Canada), respectively.**

Last Updated on 2022-05-11