

## Design/System/Construction/Assembly Usage Disclaimer

- Authorities Having Jurisdiction should be consulted in all cases as to the particular requirements covering the installation and use of UL Certified products, equipment, system, devices, and materials.
- Authorities Having Jurisdiction should be consulted before construction.
- Fire resistance assemblies and products are developed by the design submitter and have been investigated by UL for compliance with applicable requirements. The published information cannot always address every construction nuance encountered in the field.
- When field issues arise, it is recommended the first contact for assistance be the technical service staff provided by the product manufacturer noted for the design. Users of fire resistance assemblies are advised to consult the general Guide Information for each product category and each group of assemblies. The Guide Information includes specifics concerning alternate materials and alternate methods of construction.
- Only products which bear UL's Mark are considered Certified.

BXUV - Fire Resistance Ratings - ANSI/UL 263 Certified for United States

BXUV7 - Fire Resistance Ratings - CAN/ULC-S101 Certified for Canada

[See General Information for Fire-resistance Ratings - ANSI/UL 263 Certified for United States Design Criteria and Allowable Variances](#)

[See General Information for Fire Resistance Ratings - CAN/ULC-S101 Certified for Canada Design Criteria and Allowable Variances](#)

## Design No. G558

February 28, 2024

**Restrained Assembly Rating — 1 Hr**

**Unrestrained Assembly Rating — 1 Hr**

**This design was evaluated using a load design method other than the Limit States Design Method (e.g., Working Stress Design Method). For jurisdictions employing the Limit States Design Method, such as Canada, a load restriction factor shall be used — See Guide [BXUV](#) or [BXUV7](#)**

**\* Indicates such products shall bear the UL or cUL Certification Mark for jurisdictions employing the UL or cUL Certification (such as Canada), respectively.**

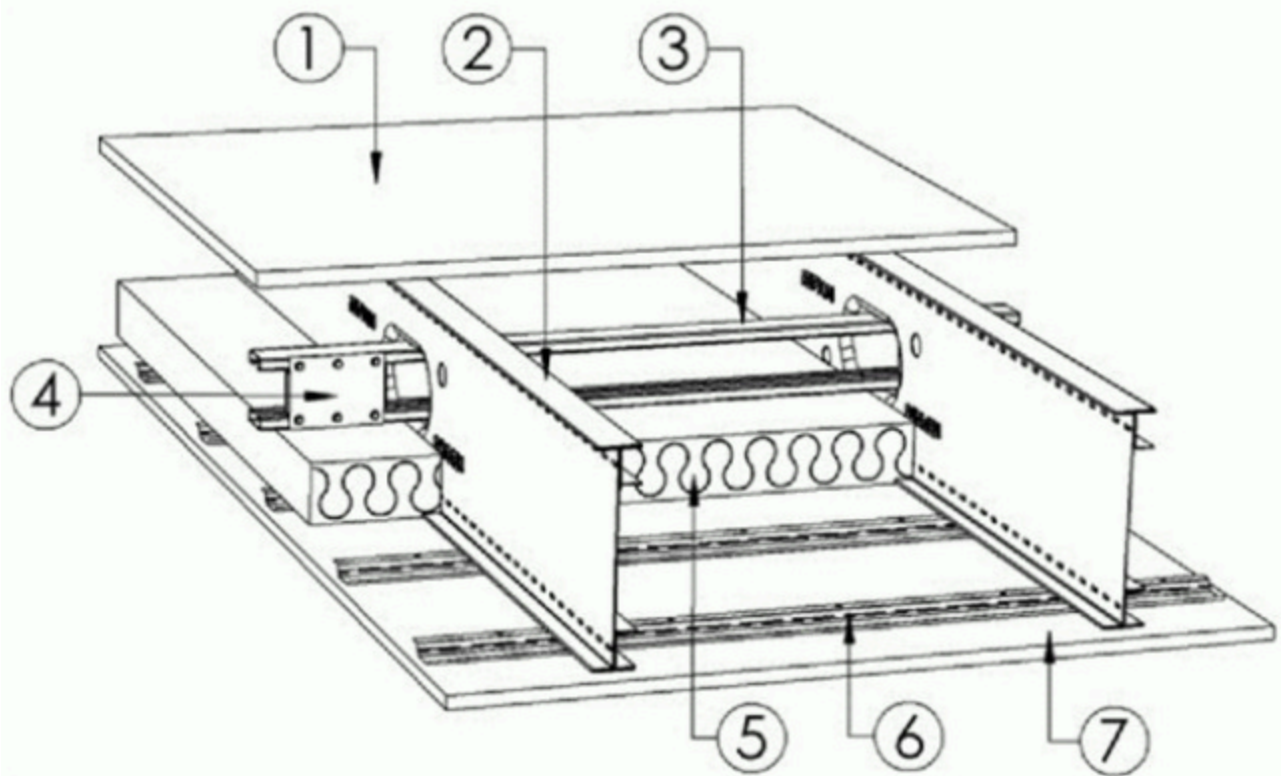

Joist	Weight (plf)	Allowable Strength			Factored Resistance		
		$M_a$ (k-ft)	$V_a$ (kip)	$V_{ah}$ (kip)	$M_r$ (k-ft)	$V_r$ (kip)	$V_{rh}$ (kip)
12-i-2	4.53	4.33	1.48	1.03	6.87	2.25	1.57
12-i-3	5.61	5.68	2.31	1.62	9.02	3.51	2.46
12-i-4	6.94	7.18	3.61	2.53	11.4	5.48	3.84
14-i-2	4.90	5.17	1.48	1.03	8.20	2.25	1.57
14-i-3	6.07	6.80	2.31	1.62	10.8	3.51	2.46
14-i-4	7.52	8.65	3.61	2.53	13.7	5.48	3.84
16-i-2	5.27	6.01	1.48	1.03	9.53	2.25	1.57
16-i-3	6.53	7.92	2.31	1.62	12.6	3.51	2.46
16-i-4	8.09	10.1	3.61	2.53	16.0	5.48	3.84

**Notation**

$M_a$  - flexural resistance in accordance with Allowable Stress Design

$V_a$  - shear resistance in accordance with Allowable Stress Design at gross section (solid web)

$V_{ah}$  - shear resistance in accordance with Allowable Stress Design at net section (hole location)

$M_r$  - flexural resistance in accordance with Load and Resistance Factor Design

$V_r$  - shear resistance in accordance with Load and Resistance Factor Design at gross section (solid web)

$V_{rh}$  - shear resistance in accordance with Load and Resistance Factor Design at net section (hole location)

1. **Structural Cement-Fiber Units\*** — Subfloor of minimum 3/4 in thick tongue-and-groove cement-fiber board. Long edges of board to be perpendicular to joists with ends staggered and centered over structural steel members. The board is to be fastened to the steel joists with #8 self drilling, self tapping cement board screws 1-5/8 in. long. Screws shall be spaced 1/2 in. from end joints and 8 in. OC along the end joints, and 1 and 2 in. from side joints and 12 in. OC in the field of each sheet.

**UNITED STATES GYPSUM CO** — Types STRUCTO-CRETE, USGSP

2. **Structural Steel Members\*** — "TotalJoist™"- Minimum 12 in. deep, 18 ga, spaced maximum 24 in. OC. Web stiffeners screwed to both ends of joists using 6 hex head, self drilling, self tapping #12 steel screws 1.0 in long and to steel C-shaped assembly tracks (rim joists) using 3 hex-head, self drilling, self tapping #12 steel screws 1.0 in. long. Effects of loads for the "TotalJoist™" shall not exceed those calculated on the basis of the joist section properties as shown in the table above. Refer to the joist manufacturer's installation instructions for detailed design information.

**Bailey Metal Products Limited** — "TotalJoist™"

3. **Bridging\*** — "TotalJoist™" snap-on bridging, 1-7/8 in. by 5/8 in. by minimum 20 GA. bridging attached to bottom chords on each joist and located 8 ft - 0 in. apart or at mid-point of joist for shorter spans. Bridging attached to chords of each joist using 1-No.12-14, 3/4 in. long, self-drilling screw.

**Optional Bridging\*** — "TotalJoist™" Bridging, 1-7/8 in. by 5/8 in. by minimum 20 GA. Bridging installed perpendicular to joists through web holes and located 8ft- 0 in. apart or at mid-point of joist for shorter spans. Bridging attached to flange of web hole in each joist using 1 hex head, self-drilling, self-tapping #10 screw, 3/4 in. long. Alternatively, bridging may be attached to joists using minimum 3/4 in. by 3/4 in. by 20 GA. clip angle. Clip angle fastened to joist web and to bridging using 1 hex head, self-drilling, self-tapping #10 screw, 3/4 in. long.

**Bailey Metal Products Limited** — "TotalJoist™" Snap-On Bridging, "TotalJoist™" Bridging.

4. **Blocking\*** — "TotalJoist™" Blocking, 18 GA. Blocking attached to every fifth bridging location between joists using 2-No.12-14, 1 in. long, self-drilling screws

4A. **Alternative Blocking (not shown)** — "TotalJoist™" cut to fit the space between the two adjacent joists and attached to joists with 16 ga. 6 in. by 3 in. Angle connected to blocking and joist with 2-#12-14, 1 in. long. self-drilling screws on each leg of the angle.

**Bailey Metal Products Limited** — "TotalJoist™" Blocking

5. **Batts and Blankets** — Glass fiber insulation, min 3-1/2 in. thick, min 0.6 lb/cu ft density, bearing the UL Classification Marking for Surface Burning Characteristics and having a flame spread value of 25 or less and a smoke developed value of 50 or less. Insulation fitted in the concealed space, draped over the resilient channels and gypsum board ceiling membrane.

6. **Resilient Channels** — Minimum 26 GA galvanized steel. Channels shall be spaced maximum 12 in. apart and attached to the bottom flange of each joist with one 1/2 in. long wafer head self-drilling, self-tapping #8 steel screw. At locations where gypsum board end joints occur, additional resilient channels shall be installed to provide screw attachments for the gypsum board ends. These additional channels shall be positioned so that the distance from the end of the board to the centre of the first channel is 3 in. and from the board end to the centre of the next channel is 12 in.

6A. **Steel Framing Members\*** — (Optional, Not Shown) — As an alternate to Item 6 — Furring channels and Steel Framing Members as described below:

a. **Furring channels** — Formed of No. 25 MSG galv steel, 2-3/8 in. wide by 7/8 in. deep, spaced 12 in. OC, perpendicular to joists. Channel secured to joists as described in Item b. Ends of adjoining channels overlapped 6 in. and tied together with double strand of No. 18 SWG galv steel wire near each end of overlap. Additional channels shall be positioned so that the distance from the end of the board to the center of the first channel is 3 in. and from the board end to the center of the next channel is 12 in.

b. **Steel Framing Members\*** — Used to attach furring channels (Item a) to joists (Item 2). Clips spaced 48 in. OC and secured to the bottom chord of joists with min 1-5/8 in. long No. 8 self-drilling, self-tapping, bugle, flat or hex head screw through the center grommet. Furring channels are friction fitted into clips. Additional clips required to hold furring channel that supports the gypsum board butt joints.

**PLITEQ INC** — Type Genie Clip

**6B. Alternate Steel Framing Members\*** — (Optional, Not Shown) — As an alternate to Items 6 to 6A, furring channels and Steel Framing Members as described below.

a. **Furring channels** — Formed of No. 25 MSG galv steel. 2-9/16 in. or 2-23/32 in. wide by 7/8 in. deep, spaced 12 in. OC, perpendicular to joists. Channels secured to joists as described in Item b. Ends of adjoining channels overlapped 6 in. and tied together with double strand of No. 18 SWG galv steel wire near each end of overlap.

b. **Steel Framing Members\*** — Used to attach furring channels (Item a) to the steel joists (Item 2). Clips spaced a max of 48 in. OC. RSIC-1 and RSIC-1 (2.75) clips secured to alternating joists with No. 8 x 2-1/2 in. coarse drywall screw through the center grommet. Furring channels are friction fitted into clips. RSIC-1 clips for use with 2-9/16 in. wide furring channels. RSIC-1 (2.75) clips for use with 2-23/32 in. wide furring channels. Adjoining channels are overlapped as described in Item a. As an alternate, ends of adjoining channels may be overlapped 6 in. and secured together with two self-tapping No. 6 framing screws, min. 7/16 in. long at the midpoint of the overlap, with one screw on each flange of the channel. Additional clips required to hold furring channel that supports the wallboard butt joints, as described in Item 7.

**PAC INTERNATIONAL L L C** — Types RSIC-1 or RSIC-1 (2.75)

7. **Gypsum Board\*** — Nominal 5/8 in. thick, 48 in. wide gypsum board installed with long dimension perpendicular to resilient/furring channels. Gypsum board shall be attached to resilient/furring channels using 1 in. long Type S drywall screws, spaced 8 in. OC in the field of each board. At the side joints, screws shall be located 1-1/2 in. and 4 in. from the board edge. At the end joints, screws shall be located 3 in. and 12 in. from the board end. When **Steel Framing Members** (Item 6A or 6B) are used, the butt joints in the gypsum board shall be supported by two furring channels. The two furring channels shall be spaced approximately 3-1/2 in. OC, and be attached to underside of the joist with one RSIC-1, RSIC-1 (2.75) or Genie clip at each end of the channel.

**CGC INC** — Type C, ULIX

**UNITED STATES GYPSUM CO** — Type C, ULIX

**USG MEXICO S A DE C V** — Type C

8. **Joint System** — (Not shown) Paper tape embedded in joint compound over joints and covered with 2 layers of compound with edges feathered out. Wallboard screw heads covered with 2 layers of compound.

**\* Indicates such products shall bear the UL or cUL Certification Mark for jurisdictions employing the UL or cUL Certification (such as Canada), respectively.**

Last Updated on 2024-02-28

---

The appearance of a company's name or product in this database does not in itself assure that products so identified have been manufactured under UL Solutions' Follow - Up Service. Only those products bearing the UL Mark should be considered to be Certified and covered under UL Solutions' Follow - Up Service. Always look for the Mark on the product.

UL Solutions permits the reproduction of the material contained in Product iQ subject to the following conditions: 1. The Guide Information, Assemblies, Constructions, Designs, Systems, and/or Certifications (files) must be presented in their entirety and in a non-misleading manner, without any manipulation of the data (or drawings). 2. The statement "Reprinted from Product iQ with permission from UL Solutions" must appear adjacent to the extracted material. In addition, the reprinted material must include a copyright notice in the following format: "©2025 UL LLC."