

Design/System/Construction/Assembly Usage Disclaimer

- Authorities Having Jurisdiction should be consulted in all cases as to the particular requirements covering the installation and use of UL Certified products, equipment, system, devices, and materials.
- Authorities Having Jurisdiction should be consulted before construction.
- Fire resistance assemblies and products are developed by the design submitter and have been investigated by UL for compliance with applicable requirements. The published information cannot always address every construction nuance encountered in the field.
- When field issues arise, it is recommended the first contact for assistance be the technical service staff provided by the product manufacturer noted for the design. Users of fire resistance assemblies are advised to consult the general Guide Information for each product category and each group of assemblies. The Guide Information includes specifics concerning alternate materials and alternate methods of construction.
- Only products which bear UL's Mark are considered Certified.

BXUV - Fire Resistance Ratings - ANSI/UL 263 Certified for United States

BXUV7 - Fire Resistance Ratings - CAN/ULC-S101 Certified for Canada

[See General Information for Fire-resistance Ratings - ANSI/UL 263 Certified for United States Design Criteria and Allowable Variances](#)

[See General Information for Fire Resistance Ratings - CAN/ULC-S101 Certified for Canada Design Criteria and Allowable Variances](#)

Design No. G557

June 20, 2023

Unrestrained Assembly Rating - 2 Hr

This design was evaluated using a load design method other than the Limit States Design Method (e.g., Working Stress Design Method). For jurisdictions employing the Limit States Design Method, such as Canada, a load restriction factor shall be used — See Guide [BXUV](#) or [BXUV7](#)

*** Indicates such products shall bear the UL or cUL Certification Mark for jurisdictions employing the UL or cUL Certification (such as Canada), respectively.**

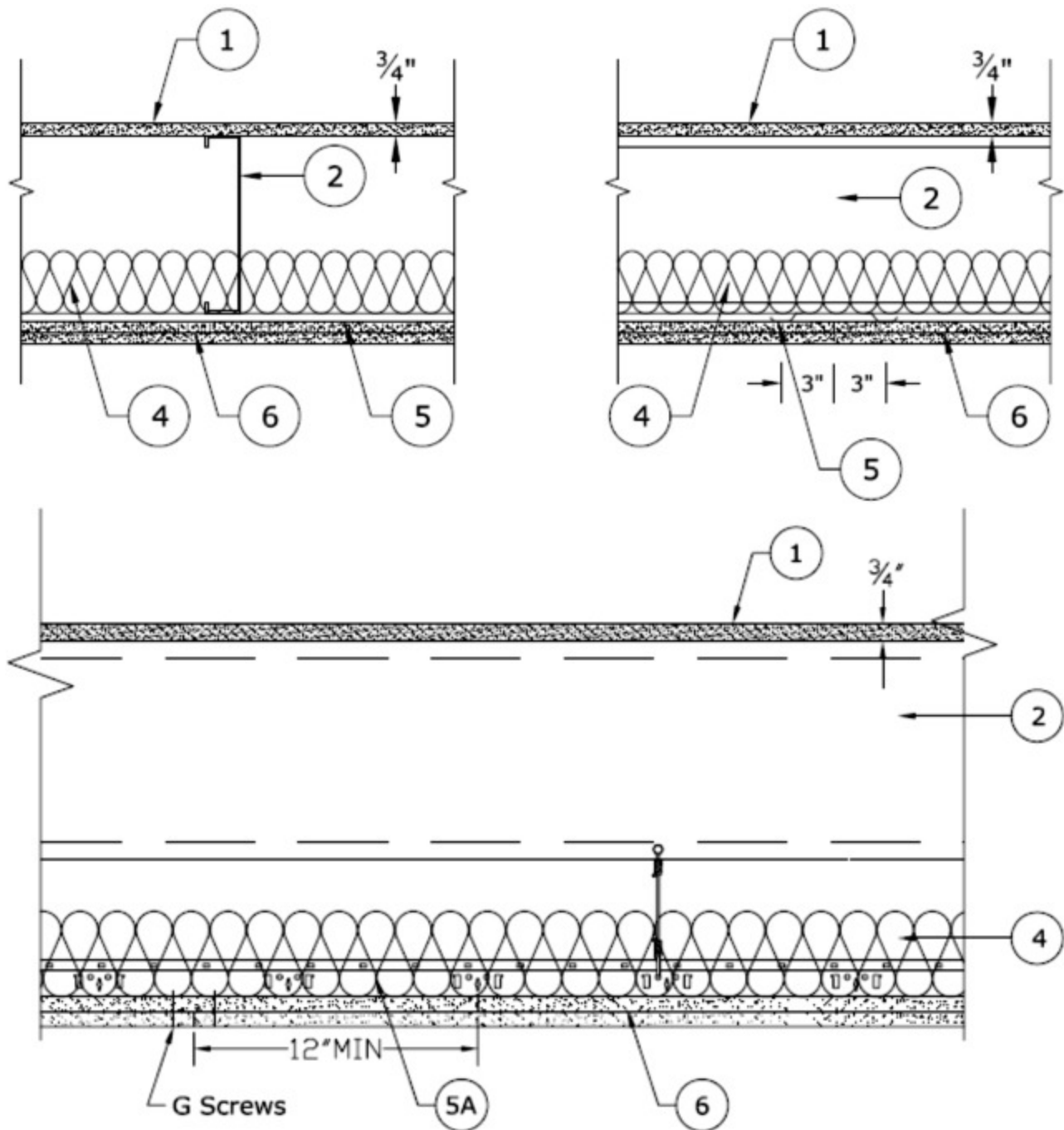

1. Flooring System - Structural Cement-Fiber Units* — Nom 3/4 in. thick, with long edges tongue and grooved. Long dimension of panels to be perpendicular to joists with end joints staggered a min of 2 ft and centered over the joists. Panels secured to steel joists with 1-5/8 in. long No. 8 self-drilling, self-countersinking steel screws spaced a max of 12 in. OC in the field with a screw located 1 in. (25 mm) and 2 in. from each edge, and 8 in. OC on the perimeter with a screw located 2 in. from each edge, located 1/2 in. from the side edges of the panel.

As an alternate to the 1-5/8" long No. 8 fastener, the following power-actuated pins may be used for min. 1/8" thick, hot-rolled A36 steel sections for joist specified in Item 2:

Hilti pin model X-U 32MX with a min. 0.157" shank diameter min. 1-1/4" long, DeWalt pin model 50458-PWR with a min. 0.157" shank diameter min. 1-1/4" long or Aerosmith model 5324HPG with a min. 0.145 shank diameter min. 1-1/4" long.

UNITED STATES GYPSUM CO — Types STRUCTO-CRETE, USGSP

2. Steel Joists — Channel-shaped, min 10 in. deep with min 1-5/8 in. wide flanges and 1/2 in. long stiffening flanges. Fabricated from min No. 16 MSG galv steel. Min yield strength of 50,000 psi. Joists spaced max 24 in. OC. Supplied with appropriate rim tracks of same size and gauge.

2A. **Steel Joists** — (Not Shown) -As an alternate to Item 2 - For maximum clear spans not exceeded 8 ft. Channel-shaped, min 6 in. deep with min 1-9/16 in. wide flanges and 3/8 in. long stiffening flanges. Fabricated from min No. 18 MSG galv steel. Min yield strength of 33,000 psi. Joists spaced max 24 in. OC. Supplied with appropriate rim tracks of same size and gauge.

2B. **Steel Joists** — (Not Shown) -As an alternate to Item 2 - Channel-shaped, min 8 in. deep with min 1-9/16 in. wide flanges and 3/8 in. long stiffening flanges. Fabricated from min No. 16 MSG galv steel. Min yield strength of 33,000 psi. Joists spaced max 24 in. OC. Supplied with appropriate rim tracks of same size and gauge.

2C. **Steel Joists** — As an alternate to item 2 only - The joists are channel-shaped, 10 in. min depth. Joists are fabricated from min No. 16 MSG galv steel. Joists spaced max 24 in. OC. Joists attached to rim joist with a minimum three #10 3/4 in. long self-drilling screws at the rim track clip to the outside of the web joist, and a #10 1/2 in. long screw through the top and bottom flange of the joists to the top and bottom flange of the rim track. At rim joist splices bearing on supports, rim joists are connected using an overlapping section of a 12 in. long splice plate (a joist piece), with a minimum of six 3/4 in. long self-drilling #10 screws to each rim piece. For use with item 3C.

CEMCO, LLC — Type SSCJ floor joists, SSRT rim joists or Type SSTT rim joists. When Type SSTT rim joists are used, secured to preformed clip tabs in accordance with manufacturers installation instructions.

2D. **Clip Angles** — No. 16 MSG, 9-3/4 in. long steel angles with 2 in. legs. Secured to track and joist with eight No.10, 3/4 in. long, self drilling, hex head screws, located 1 in. from each end of clip angle, with the other two screws on each leg evenly spaced. Only one clip angle per joist end.

2E. **Clip Angles** — (Not Shown) - As an alternate to Item 2C, for use with 6 or 8 in. deep joists (Item 2A or 2B). No. 16 MSG, 5-1/2 in. long steel angles with 1-1/2 in. legs for 6 in. deep joists and No. 18 MSG, 7-1/4 in. long steel angles with 1-1/2 in. legs for 8 in. deep joists. Secured to track and joist with six No.10, 3/4 in. long, self drilling, hex head screws, located 1 in. from each end of the clip angle and at the centerline. Only one clip angle per joist end.

2F. **Structural Steel Members*** — (Not Shown) - As an alternate to Item 2 - Pre-fabricated light gauge steel truss system minimum depth 12 in., consisting of cold-formed, galv steel chord and web sections. Trusses fabricated in various sizes, and various steel thickness spaced maximum of 24 in. OC.

AEGIS METAL FRAMING, DIV OF MITEK — Ultra-Span, Pre-fabricated Light Gauge Steel Truss System

TRUSSTEEL, DIV OF ITW BUILDING COMPONENTS INC — Trus Steel

2G. **Structural Steel Members*** — (Not Shown) - As an alternate to Item 2, - Pre-fabricated steel truss system consisting of cold-formed, galvanized steel chord and web sections. Truss top and bottom chords min. 4 in. high by 1-11/16 in. wide by 18 ga. Truss webs min. 1-1/2 in. by 1-1/2 in. by 20 ga. square tube bent and triangulated as shown. Chords and web connected by fillet welds. Overall truss depth min. 12 in. Trusses spaced a max of 24 in. OC. Truss ends placed over and secured to Bearing Seats (Item 2G1) with two min. #10 by 3/4 in. long screws on each side of Bearing Seats. Allowable loading must be calculated so as to stress the steel trusses to a maximum of 98% of the stress calculated in accordance with the allowable stress design approach outlined in the manufacturer's load tables.

EISEN PANEL SYSTEMS L L C — Type Gateway Panel pre-fabricated steel truss system.

2G1. **Bearing Seats*** — (Not Shown) — Galvanized steel tube, min. 1 in. by 2-1/2 in. by 13 ga., oriented vertically and welded to min. 4 in. by 4 in. by 10 ga., galvanized steel plate. Bearing seats spaced 24 in. OC and attached to bearing supports by welding or screw attaching the steel plate to the bearing supports.

EISEN PANEL SYSTEMS L L C — Type Gateway Panel bearing seat.

2G2. **Bracing** — (Not Shown) - For use with Item 2G — Galvanized channel-shaped steel sections, min. 1-1/2 in. wide with 1/4 in. flanges, min. 16 ga. Bracing attached to underside of trusses with min. #10 by 3/4 in. long screws through truss bottom chord. Bracing installed in truss cavities by scoring, bending and flattening the ends to form a tab for attachment to truss top and bottom chords. Two pieces of bracing crossed and tabs secured to truss chords with min. #10 by 3/4 in. long screws. Location and spacing of underside and crossed bracing to be specified on truss engineering.

2H. **Steel Trusses** — — As an alternate to Item 2, - Cold-formed galvanized steel truss chord and web sections manufactured from steel conforming to ASTM A653 Grade 33 or higher yield strength. Steel thickness of truss chord and web sections as required by

design to meet governing code requirements. Truss members connected together with No. 10-16 (min size) self-drilling screws or equivalent. Truss chord and web members to be designed in accordance with the American Iron and Steel Institute's Specification for the Design of Cold-Formed Steel Structural Members, 1996 Edition. Trusses spaced a max of 24 in. OC. Where the truss intersects with the interior face of the exterior walls, the min truss depth shall be 12 in.

2I. **Steel Joists** — As an alternate to Item 2, minimum 12K1, spaced a max 24 in. OC.

2J. **Structural Steel Members*** — As an alternate to Item 2 - Limited to the 1 Hour Ratings. Pre-fabricated light gauge steel truss system consisting of cold-formed, galv steel cord and web sections. Trusses fabricated in various sizes, depths and from various steel thickness. Trusses spaced a max of 24 in. OC. Location of lateral bracing for truss chord and web sections to be specified on truss engineering.

TRUSS LINK INC — Truss Link

3. **Joist Bridging** — (Not Shown) - For use with Item 2 and 2B - Installed immediately after joists are erected and before construction loads are applied. The bridging consisting of joist sections cut to length and placed between outer supports, adjacent to openings and at mid span with 8 ft OC max spacing. Bridging channels are screw-attached at each end to joist web using angle clips. V-bracing of 1-1/2 in. by 20-ga galvanized steel is screw-attached to bottom joist flange between bridging channels.

3A. **Joist Bridging** — (Not Shown) - For use with Item 2A - Installed immediately after joists are erected and before construction loads are applied. The bridging consisting of rim track sections cut to length, with two 4 in. long folded back flanges, and placed between outer supports, adjacent to openings and at mid span with 10 ft OC max spacing. Bridging channels are screw-attached to each of the four top and bottom joist flanges with two No. 8 by 1/2 in. long wafer head steel screws.

3B. **Joist Bridging** — (Not Shown) - For use with Item 2A and 2B - 1-1/2 in. wide strips formed from 20 MSG - The structural bridging is installed perpendicular to and on the bottom surface of the joists at mid-span with one #10 x 3/4 in. long hex head steel screw at each interface.

3C. **Joist Bridging** — Not shown — For use with item 2C. Installed immediately after joists are erected and before construction loads are applied. The structural bridging, Type CEMCO Sure Bridging, consisting of No. 18 MSG galv steel, 2-1/2 in. wide by 25-1/2 in. long with 1-5/16 in. long legs structural bridging staggered between the steel joists and attached to the bottom joist flange with two #10 1/2 in. long self-drilling screws at each end tab of bridging. Solid bridging consisting of cut to length joist sections placed between outer joists and at center joist with 8 ft OC max spacing. Solid bridging is seated in the structural bridging and is screw-attached at joist web using Type CEMCO Sure-Support Clips (1-1/2 in. by 1-1/2 in. by 7 in. long, 16 MSG, min 50 ksi support clip) with three #10 3/4 in. long self-drilling screws per leg on one side and the other side with Type CEMCO Sure-Support Clips (4 in. by 1-1/2 in. by 7 in. long, 16 MSG, min 50 ksi support clip) with three #10 3/4 in. long self-drilling screws per leg.

3D. **Bridging** — (Not Shown)—For use with Item 2F - Location of lateral bracing for truss chord and web sections to be specified on truss engineering.

4. **Batts and Blankets*** — 3-5/8 in. thick glass fiber batt insulation draped over the resilient channels (Item 5) or suspension system grid (Item 5A). Any glass fiber batt insulation bearing the UL Classification Marking for Surface Burning Characteristics having a flame spread index of 25 or less and a smoke developed index of 50 or less may be used. See **Batts and Blankets** (BKNV) category in the Building Materials Directory for names of manufacturers.

5. **Resilient Channels** — Formed of No. 25 MSG galv steel, 1/2 in. deep, spaced max 12 in. OC, perpendicular to joists. Channel splices located beneath joists and overlapped 4 in. Channels secured to each joist with one 1/2 in. long Type S-12 low profile steel screw. Two channels, spaced 6 in. OC, oriented opposite each gypsum board end joint as shown on the illustration above. Additional channels shall extend min 6 in. beyond each side edge of board.

5A. **Steel Framing Members*** — (Optional, Not Shown) — When it is desired to drop the ceiling below the bottom plane of the structural steel members (Item 2), a suspension system may be used in lieu of the resilient channels. Main runners, cross tees, cross channels and wall angle as listed below:

a. **Main Runners** — Nom 10 or 12 ft long, 15/16 in. or 1-1/2 in. wide face, spaced 4 ft. OC. Main runners suspended by min 12 SWG galv steel hanger wires spaced 24 in. OC, a min of 4 in. below bottom flange of joist, twist-tied to #10 -3/4 in. long screws installed in the web, 1/2 in. from the bottom flange of the steel joist. Hanger wires to be located adjacent to main runner/cross tee intersections.

b. **Cross Tees** — Nom 4 ft long, 1-1/2 in. wide face, installed perpendicular to the main runners, spaced 16 in. OC. Additional cross tees or cross channels used at 8 in. from each side of butted gypsum panel end joints. The cross tees or cross channels may be riveted or screw attached to the wall angle or channel to facilitate the ceiling installation.

c. **Cross Channels** — Nom 4 ft or 12 ft long, installed perpendicular to main runners, spaced 16 in. OC.

d. **Wall Angle or Channel** — Painted or galv steel angle with 1 in. legs or channel with 1 in. legs, 1-9/16 in. deep attached to walls at perimeter of ceiling with fasteners 16 in. OC. To support steel framing member ends and for screw-attachment of the gypsum panel.

CGC INC — Type DGL or RX

USG INTERIORS LLC — Type DGL or RX.

5B. **Steel Framing Members*** — (Optional, Not Shown) — As an alternate to Item 5 — Furring channels and Steel Framing Members as described below:

a. **Furring channels** — Formed of No. 25 MSG galv steel, 2-3/8 in. wide by 7/8 in. deep, spaced 12 in. OC, perpendicular to joists. Channel secured to joists as described in Item b. Ends of adjoining channels overlapped 6 in. and tied together with double strand of No. 18 SWG galv steel wire near each end of overlap. Additional channels shall be positioned so that the distance from the end of the board to the center of the first channel is 3 in. and from the board end to the center of the next channel is 12 in.

b. **Steel Framing Members*** — Used to attach furring channels (Item a) to joists (Item 2). Clips spaced 48 in. OC and secured to the bottom chord of joists with min 1-5/8 in. long No. 8 self-drilling, self-tapping, bugle, flat or hex head screw through the center grommet. Furring channels are friction fitted into clips. Additional clips required to hold furring channel that supports the gypsum board butt joints.

PLITEQ INC — Type Genie Clip

5C. **Alternate Steel Framing Members*** — (Optional, Not Shown) — As an alternate to Items 5 to 5B, furring channels and Steel Framing Members as described below.

a. **Furring channels** — Formed of No. 25 MSG galv steel. 2-9/16 in. or 2-23/32 in. wide by 7/8 in. deep, spaced 12 in. OC, perpendicular to joists. Channels secured to joists as described in Item b. Ends of adjoining channels overlapped 6 in. and tied together with double strand of No. 18 SWG galv steel wire near each end of overlap.

b. **Steel Framing Members*** — Used to attach furring channels (Item a) to the steel joists (Item 2). Clips spaced a max of 48 in. OC. RSIC-1 and RSIC-1 (2.75) clips secured to alternating joists with No. 8 x 2-1/2 in. coarse drywall screw through the center grommet. Furring channels are friction fitted into clips. RSIC-1 clips for use with 2-9/16 in. wide furring channels. RSIC-1 (2.75) clips for use with 2-23/32 in. wide furring channels. Adjoining channels are overlapped as described in Item a. As an alternate, ends of adjoining channels may be overlapped 6 in. and secured together with two self-tapping No. 6 framing screws, min. 7/16 in. long at the midpoint of the overlap, with one screw on each flange of the channel. Additional clips required to hold furring channel that supports the wallboard butt joints, as described in Item 6.

PAC INTERNATIONAL L L C — Types RSIC-1 or RSIC-1 (2.75)

6. **Gypsum Board*** — Nom 5/8 in. thick, 48 in. wide gypsum panels. Base layer installed with long dimension perpendicular to resilient channels, furring channels or cross tees, secured with 1-1/4 in. long Type S bugle-head screws spaced 12 in. OC, with screws located 6 in. from and on each side of the gypsum panel, in both the field and the perimeter, and 1-1/2 in. from side edges of the panels. Face layer installed with long dimension perpendicular to resilient/furring channels or cross tees with joints offset 24 in. from base layer, secured with 1-5/8 in. long Type S bugle-head screws spaced 8 in. OC in both the field and the perimeter, and 1-1/2 in. from side edges of the panel. Butt joints of face layer panels secured to base layer with 1-1/2 in. long Type G screws spaced 8 in. OC and 1-1/2 in. from side edges of the panels, with butt joints located between resilient/furring channels. Butt joints of face panels staggered a minimum of 12 in. from butt joints of base layer. When **Steel Framing Members** (Item 5B or 5C) are used, the butt joints in the gypsum board shall be supported by two furring channels. The two furring channels shall be spaced approximately 3-1/2 in. OC, and be attached to underside of the joist with one RSIC-1, RSIC-1 (2.75) or Genie clip at each end of the channel.

CGC INC — Types C, IP-X2, IPC-AR, ULIX

THE SIAM GYPSUM INDUSTRY (SONGKHLA) CO — Type C

UNITED STATES GYPSUM CO — Types C, IP-X2, IPC-AR, ULIX

USG BORAL DRYWALL SFZ LLC — Type C

USG MEXICO S A DE C V — Types C, IP-X2, IPC-AR

7. **Finishing System - (Not Shown)** — Vinyl, dry or premixed joint compound, applied in two coats to joints and screw-heads. Nom 2 in. wide paper tape embedded in first layer of compound over all joints. As an alternate, nom 3/32 in. thick veneer plaster may be applied to the entire surface of gypsum board.

*** Indicates such products shall bear the UL or cUL Certification Mark for jurisdictions employing the UL or cUL Certification (such as Canada), respectively.**

Last Updated on 2023-06-20

The appearance of a company's name or product in this database does not in itself assure that products so identified have been manufactured under UL Solutions' Follow - Up Service. Only those products bearing the UL Mark should be considered to be Certified and covered under UL Solutions' Follow - Up Service. Always look for the Mark on the product.

UL Solutions permits the reproduction of the material contained in Product iQ subject to the following conditions: 1. The Guide Information, Assemblies, Constructions, Designs, Systems, and/or Certifications (files) must be presented in their entirety and in a non-misleading manner, without any manipulation of the data (or drawings). 2. The statement "Reprinted from Product iQ with permission from UL Solutions" must appear adjacent to the extracted material. In addition, the reprinted material must include a copyright notice in the following format: "©2025 UL LLC."