

# Design No. G536

November 12, 2019

## Unrestrained Assembly Rating - 2 Hr

This design was evaluated using a load design method other than the Limit States Design Method (e.g., Working Stress Design Method). For jurisdictions employing the Limit States Design Method, such as Canada, a load restriction factor shall be used — See Guide [BXUV](#) or [BXUV7](#)

\* Indicates such products shall bear the UL or cUL Certification Mark for jurisdictions employing the UL or cUL Certification (such as Canada), respectively.

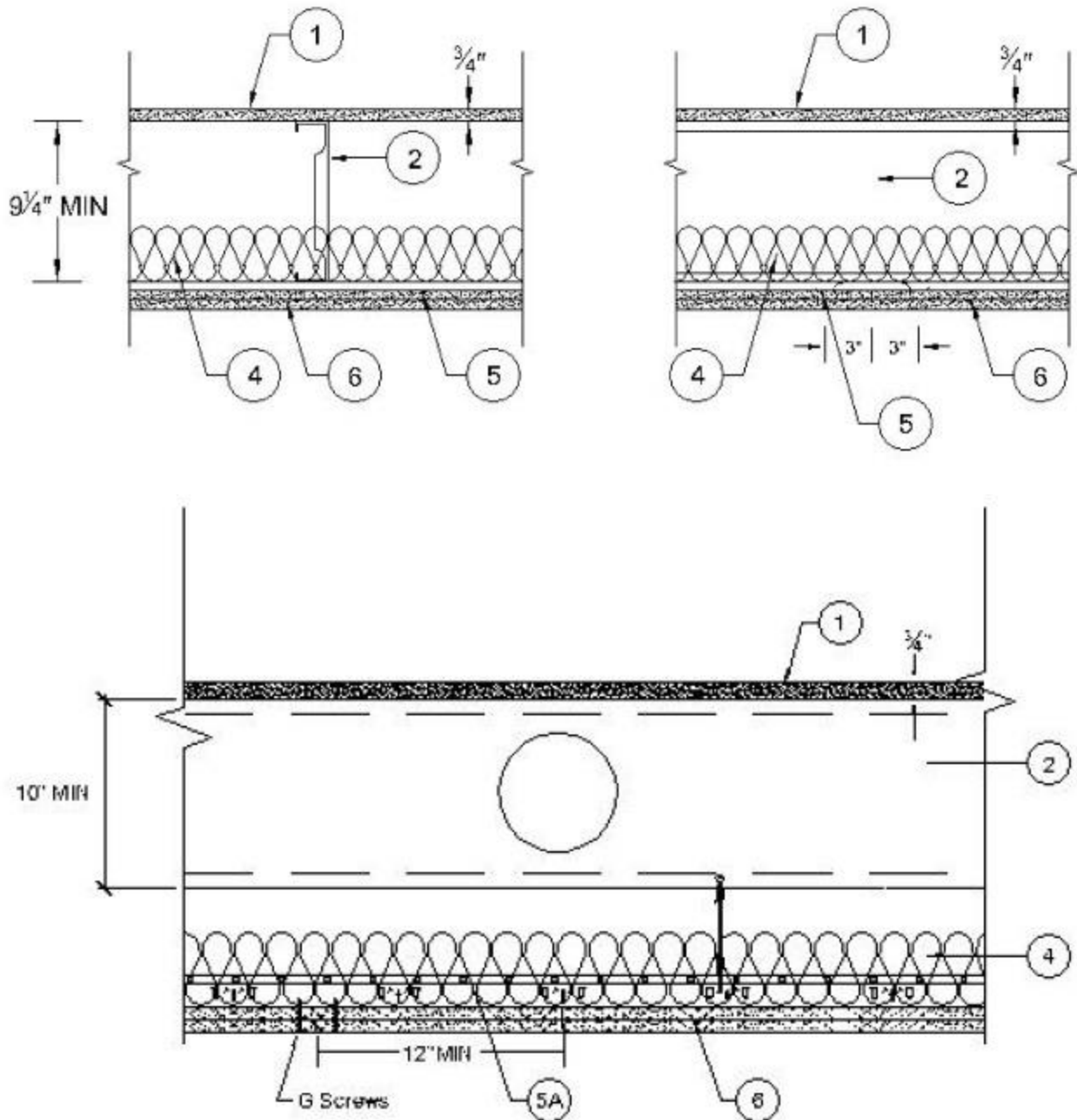

1. **Flooring System - Structural Cement-Fiber Units\*** — Nom 3/4 in. thick, with long edges tongue and grooved. Long dimension of panels to be perpendicular to joists with end joints staggered a min of 2 ft and centered over the joists. Panels secured to steel joists with 1-5/8 in. long No. 8 self-drilling, self-countersinking steel screws spaced a

max of 12 in. OC in the field with a screw located 1 in. and 2 in. from each edge, and 8 in. OC on the perimeter with a screw located 2 in. from each edge, located 1/2 in. from the side edges of the panel.

**UNITED STATES GYPSUM CO** — Types STRUCTO-CRETE, USGSP

2. **Structural Steel Members\*** — The proprietary joists are channel-shaped, min 9-1/4 in. deep. Joists are fabricated from min No. 16 MSG galv steel. Joists spaced max 24 in. OC. Joists attached to joist rim with three 3/4 in. long No. 10 x 16 self-drilling steel TEK screws through tab to the outside of the web. At joist rim splices bearing on supports, joist rims are connected using an overlapping section of a 12 in. long splice plate (a joist piece), with four 3/4 in. long No. 10 x 16 self-drilling steel TEK screws to each rim piece.

**CLARKDIETRICH BUILDING SYSTEMS** — Type TDJ or TDW Floor Joists, TD24 Rim Joist

3. **Joist Bridging - (Not Shown)** — Installed at the center of the joist span immediately after joists are erected and before construction loads are applied. The bridging (2-1/2 TDSB18) consists of No. 18 MSG galv steel channels, 2-1/2 in. wide by 1-1/4 in. deep by 21-3/4 in. long with 2-1/8 in. long web extensions at each end for screw-attachment to the bottom flange of the steel joists with a 3/4 in. long No. 10 x 16 self-drilling steel TEK screw. Solid bridging consisting of cut-to-length joist sections placed between the outermost joists and between the centermost joists with a max spacing of 8 ft OC. Solid bridging are screw-attached at joist web using a 1-1/2 by 1-1/2 by 7 in. long, No. 16 MSG, min 50 ksi steel support clip (EasyClip S-Series S547) with two 3/4 in. long No. 10 x 16 self-drilling steel TEK screws per leg on one side and on the other side with a 4 by 1-1/2 by 7 in. long No. 16 MSG, min 50 ksi steel support clip (EasyClip E-Series E547) with two 3/4 in. long No. 10 x 16 self-drilling steel TEK screws per leg.

4. **Batts and Blankets\*** — 3-5/8 in. thick glass fiber batt insulation draped over the resilient channels (Item 5) or suspension system grid (Item 5A). Any glass fiber batt insulation bearing the UL Classification Marking for Surface Burning Characteristics having a flame spread index of 25 or less and a smoke developed index of 50 or less may be used. See **Batts and Blankets** (BKNV) category in the Building Materials Directory for names of manufacturers.

5. **Resilient Channels** — Formed of No. 25 MSG galv steel, 1/2 in. deep, spaced max 12 in. OC, perpendicular to joists. Channel splices located beneath joists and overlapped 4 in.. Channels secured to each joist with one 1/2 in. long Type S-12 low profile steel screw. Two channels, spaced 6 in. OC, oriented opposite each gypsum board end joint as shown on the illustration above. Additional channels shall extend min 6 in. beyond each side edge of board.

5A. **Steel Framing Members\*** — (Optional, Not Shown) — When it is desired to drop the ceiling below the bottom plane of the structural steel members (Item 2), a suspension system may be used in lieu of the resilient channels. Main runners, cross tees, cross channels and wall angle as listed below:

a. **Main Runners** — Nom 10 or 12 ft long, 15/16 in. or 1-1/2 in. wide face, spaced 4 ft. OC. Main runners suspended by min 12 SWG galv steel hanger wires spaced 24 in. OC, a min of 4 in. below bottom flange of joist, twist-tied to #10 -3/4 in. long screws installed in the web, 1/2 in. from the bottom flange of the steel joist. Hanger wires to be located adjacent to main runner/cross tee intersections.

b. **Cross Tees** — Nom 4 ft long, 1-1/2 in. wide face, installed perpendicular to the main runners, spaced 16 in. OC. Additional cross tees or cross channels used at 8 in. from each side of butted gypsum panel end joints. The cross tees or cross channels may be riveted or screw attached to the wall angle or channel to facilitate the ceiling installation.

c. **Cross Channels** — Nom 4 ft or 12 ft long, installed perpendicular to main runners, spaced 16 in. OC.

d. **Wall Angle or Channel** — Painted or galv steel angle with 1 in. legs or channel with 1 in. legs, 1-9/16 in. deep attached to walls at perimeter of ceiling with fasteners 16 in. OC. To support steel framing member ends and for screw-attachment of the gypsum panel.

**CGC INC** — Type DGL or RX

**USG INTERIORS LLC** — Type DGL or RX.

5B. **Steel Framing Members\*** — (Optional, Not Shown) — As an alternate to Item 5 — Furring channels and Steel Framing Members as described below:

a. **Furring channels** — Formed of No. 25 MSG galv steel, 2-3/8 in. wide by 7/8 in. deep, spaced 12 in. OC, perpendicular to joists. Channel secured to joists as described in Item b. Ends of adjoining channels overlapped 6 in. and tied together with double strand of No. 18 SWG galv steel wire near each end of overlap. Additional channels shall be positioned so that the distance from the end of the board to the center of the first channel is 3 in. and from the board end to the center of the next channel is 12 in.

b. **Steel Framing Members\*** — Used to attach furring channels (Item a) to joists (Item 2). Clips spaced 48 in. OC and secured to the bottom chord of joists with min 1-5/8 in. long No. 8 self-drilling, self-tapping, bugle, flat or hex head screw through the center grommet. Furring channels are friction fitted into clips. Additional clips required to hold furring channel that supports the gypsum board butt joints.

**PLITEQ INC** — Type Genie Clip

5C. **Alternate Steel Framing Members\*** — (Optional, Not Shown) — As an alternate to Items 5 to 5B, furring channels and Steel Framing Members as described below.

a. **Furring channels** — Formed of No. 25 MSG galv steel. 2-9/16 in. or 2-23/32 in. wide by 7/8 in. deep, spaced 12 in. OC, perpendicular to joists. Channels secured to joists as described in Item b. Ends of adjoining channels overlapped 6 in. and tied together with double strand of No. 18 SWG galv steel wire near each end of overlap.

b. **Steel Framing Members\*** — Used to attach furring channels (Item a) to the steel joists (Item 2). Clips spaced a max of 48 in. OC. RSIC-1 and RSIC-1 (2.75) clips secured to alternating joists with No. 8 x 2-1/2 in. coarse drywall screw through the center grommet. Furring channels are friction fitted into clips. RSIC-1 clips for use with 2-9/16 in. wide furring channels. RSIC-1 (2.75) clips for use with 2-23/32 in. wide furring channels. Adjoining channels are overlapped as described in Item a. As an alternate, ends of adjoining channels may be overlapped 6 in. and secured together with two self-tapping No. 6 framing screws, min. 7/16 in. long at the midpoint of the overlap, with one screw on each flange of the channel. Additional clips required to hold furring channel that supports the wallboard butt joints, as described in Item 6.

**PAC INTERNATIONAL L L C** — Types RSIC-1 or RSIC-1 (2.75)

6. **Gypsum Board\*** — Nom 5/8 in. thick, 48 in. wide gypsum panels. Base layer installed with long dimension perpendicular to resilient channels, furring channels or cross tees, secured with 1 in. long Type S bugle-head screws spaced 12 in. OC, with screws located 6 in. from and on each side of the gypsum panel, in both the field and the perimeter, and 1-1/2 in. from side edges of the panels. Face layer installed with long dimension perpendicular to resilient/furring channels or cross tees with joints offset 24 in. from base layer, secured with 1-5/8 in. long Type S bugle-head screws spaced 8 in., OC, with screws located 4 in. from and on each side of the gypsum panel midspan, in both the field and the perimeter, and 1-1/2 in. from side edges of the panel. Butt joints of face layer panels secured to base layer with 1-1/2 in. long Type G screws spaced 8 in. OC and 1-1/2 in. from side edges of the panels, with butt joints located between resilient/furring channels. Butt joints of face panels staggered a minimum of 12 in. from butt joints of base layer. When **Steel Framing Members** (Item 5B or 5C) are used, the butt joints in the gypsum board shall be supported by two furring channels. The two furring channels shall be spaced approximately 3-1/2 in. OC, and be attached to underside of the joist with one RSIC-1, RSIC-1 (2.75) or Genie clip at each end of the channel.

**CGC INC** — Types C, IP-X2, IPC-AR, ULIX

**UNITED STATES GYPSUM CO** — Types C, IP-X2, IPC-AR, ULIX

**USG BORAL DRYWALL SFZ LLC** — Type C

**USG MEXICO S A DE C V** — Types C, IP-X2, IPC-AR

7. **Finishing System - (Not Shown)** — Vinyl, dry or premixed joint compound, applied in two coats to joints and screw-heads. Nom 2 in. wide paper tape embedded in first layer of compound over all joints. As an alternate, nom 3/32 in. thick veneer plaster may be applied to the entire surface of gypsum board.

**\* Indicates such products shall bear the UL or cUL Certification Mark for jurisdictions employing the UL or cUL Certification (such as Canada), respectively.**

[Last Updated](#) on 2019-11-12