

# Design No. G534

March 10, 2020

Restrained Assembly Rating — 1 Hr

Unrestrained Assembly Rating — 1 Hr

This design was evaluated using a load design method other than the Limit States Design Method (e.g., Working Stress Design Method). For jurisdictions employing the Limit States Design Method, such as Canada, a load restriction factor shall be used — See Guide [BXUV](#) or [BXUV7](#)

\* Indicates such products shall bear the UL or cUL Certification Mark for jurisdictions employing the UL or cUL Certification (such as Canada), respectively.

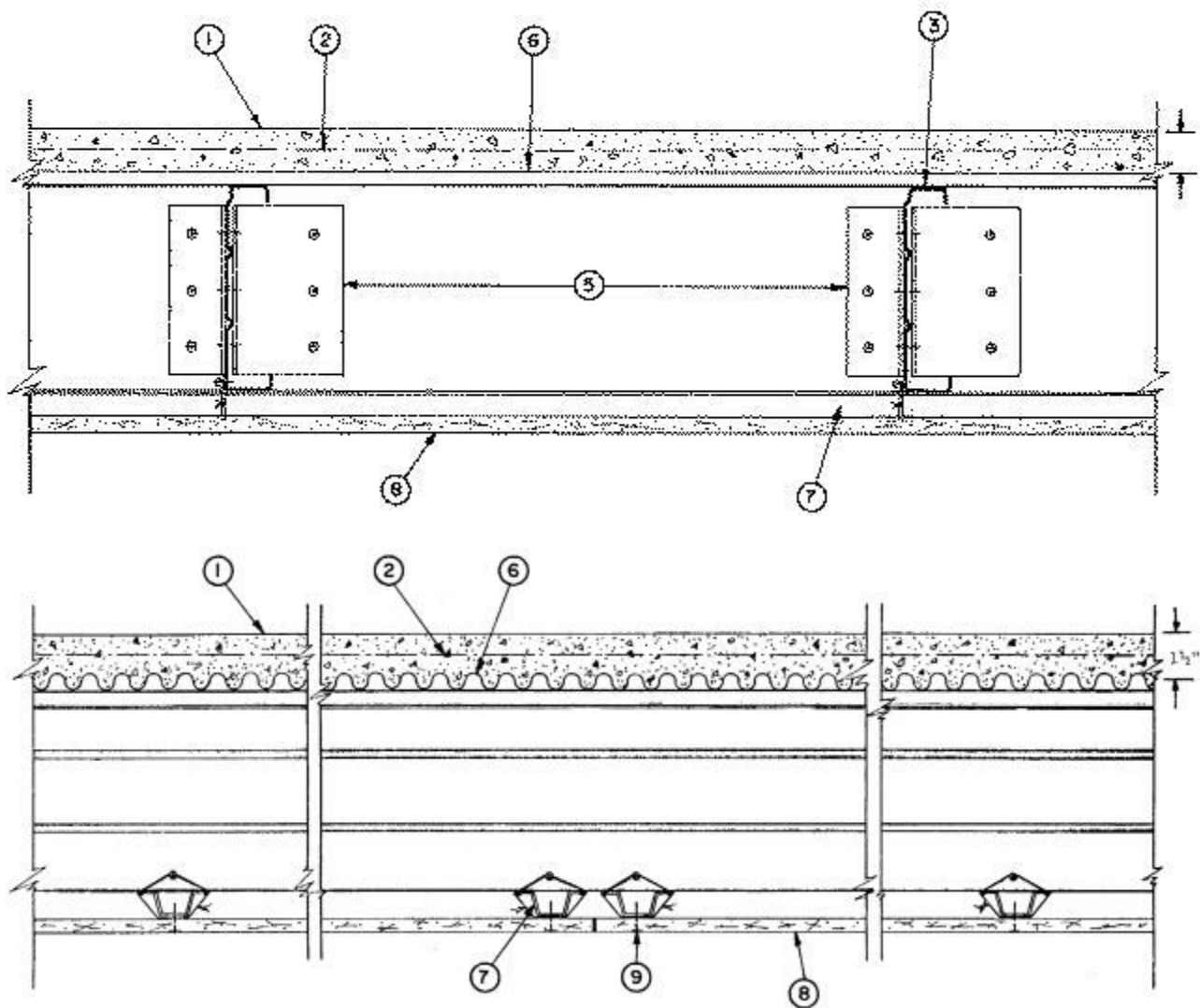

1. **Lightweight Concrete** — Expanded shale, clay or slate aggregate by rotary kiln method, 115 plus or minus 6 pcf unit weight, 3400 psi compressive strength, 5 to 7 percent entrained air. Min 1-1/2 in. thick.

2. **Welded Wire Fabric** — 6x6, 10/10 SWG.

3. **Steel Joist** — Non-Composite Design — Spaced 24 in. O.C. Channel-shaped, 7-3/16 in. deep with min 1-5/8 in. flanges and 9/16 in. stiffening flanges. Fabricated from min No. 18 MSG galv steel. Min yield strength of steel is 33,000 psi with corresponding max working stress of 20,000 psi.

4. **Bridging (not shown)** — Same as steel joints (Item 3). Located 8 ft max O.C. perpendicular to the joists, 2x2x4 in. angle clips used to connect web back to web back, 2x4x6 in. angle clips used to connect web back to web inside. Six 1/2 in. Type S-12 self-drilling, self-tapping screws used with each angle clip.

5. **Angle Clips** — 2x2x6 in., No. 15 ga (0.075 in. thick) clips used to fasten joists to joist headers and bridging to joists with clip located on the web side opposite the flanges. 2x4x6 in. No. 20 ga (0.034 in. thick) clips used to fasten bridging to joists on the flange side of the bridging.

6. **Steel Form Units** — Min 19/32 in. deep, 30 in. wide corrugated steel deck. Crests 1/2 in. wide, pitch 2-9/16 in., No. 28 MSG (0.018 in. thick) galv steel. Overlapped one corrugation at each side and attached to each joist with 5/8 in. long Type S-12 steel screws at each side joint and not more than 12-3/8 in. O.C. between sides. Concrete thickness measured at crests.

7. **Furring Channels** — No. 26 MSG galv steel 1-1/4 in. wide with two 15/32 in. flanges, (overall width approximately 2-3/16 in. or 2-9/16 in. or 2-23/32 in.) spaced 24 in. O.C. perpendicular to joists and supported at each joist by a double strand of No. 18 SWG galv. Wire is twist-tied to 1 in. long Type S-12 bugle head screws with steel washers that are secured to web of joists spaced as required for support of furring channel.

Adjoining lengths of channels overlapped 6 in. and tied together with double strand of No. 18 SWG galv steel wire at each end of overlap. Two courses of channels used at each end joint of gypsum wallboard located 1-5/8 in. on each side of each end joint.

7A. **Steel Framing Members\*** — (optional, not shown) — alternate method to attach furring channels (Item 7) to joists (Item 3). Clips spaced 48 in. OC., RSIC-1 and RSIC-1 (2.75) clips secured to alternating joists with 1-5/8 in. wafer or hex head Type S steel screw through the center grommet. RSIC-V and RSIC-V (2.75) clips secured to alternating joists with 5/8 in. wafer or hex head Type S steel screw through the center hole. Furring channels are friction fitted into clips. RSIC-1 and RSIC-V clips for use with 2-9/16 in. wide furring channels. RSIC-1 (2.75) and RSIC-V (2.75) clips for use with 2-23/32 in. wide furring channels. Ends of adjoining channels are overlapped 6 in. and tied together with double strand of No. 18 SWG galv steel wire near each end of overlap. As an alternate, ends of adjoining channels may be overlapped 6 in. and secured together with two self-tapping No. 6 framing screws, min. 7/16 in. long at the midpoint of the overlap, with one screw on each flange of the channel. Additional clips required to hold furring channel that supports the wallboard butt joints, as described in Item 8.

**PAC INTERNATIONAL L L C** — Types RSIC-1, RSIC-V, RSIC-1 (2.75), RSIC-V (2.75).

7B. **Steel Framing Members\*** — (optional, not shown) — alternate method to attach 2-3/8 in. wide furring channels (Item 7) to joists (Item 3). Clips spaced 48 in. OC., GenieClips secured to alternating joists with 1-5/8 in. wafer or hex head Type S steel screw through the center grommet. Furring channels are friction fitted into clips. Ends of adjoining channels are overlapped 6 in. and tied together with double strand of No. 18 SWG galv steel wire near each end of overlap. As an alternate, ends of adjoining channels may be overlapped 6 in. and secured together with two self-tapping No. 6 framing screws, min. 7/16 in. long at the midpoint of the overlap, with one screw on each flange of the channel. Additional clips required to hold furring channel that supports the wallboard butt joints, as described in Item 8.

**PLITEQ INC** — Type GENIECLIP

7C. **Steel Framing Members\*** — (Optional, Not Shown) - Used as an alternate method to attach furring channels (Item 7) to joists (Item 3). Clips spaced at 48" OC and secured to the bottom of the joists with 1-5/8 in. wafer or hex head Type S steel screw through the center grommet. Furring channels are then friction fitted into clips. Ends of channels are overlapped 6" and tied together with double strand of No. 18 AWG galvanized steel wire. Additional clips are required to hold the Gypsum Butt joints as described in Item 8.

**STUDCO BUILDING SYSTEMS** — RESILMOUNT Sound Isolation Clips - Type A237 or A237R

8. **Gypsum Board\*** — 1/2 in. thick, 4 ft wide, installed with the long dimension perpendicular to the furring channels. End joints of boards staggered or in line, to occur between channels spaced 3-1/4 in. OC. Attached to each channel with wallboard screws spaced 8 in. OC and 1 in. from each edge of board.

When **Steel Framing Members** (Item 7A or 7B) are used, wallboard butt joints shall be staggered min. 2 ft. within the assembly, and occur between the main furring channels. Edge joints may occur beneath the joists. At the wallboard butt joints, each end of the gypsum board shall be supported by a single length of furring channel equal to the width of the wallboard plus 6 in. on each end. The furring channels shall be spaced approximately 3-1/2 in. OC, and be attached to underside of the joist with one clip at each end of the channel. Gypsum board attached to the furring channels using 1 in. long Type S bugle-head steel screws spaced 8 in. OC along butted end joints and 12 in. OC in the field of the board. Wallboard joints covered with fiber tape and joint compound.

When Steel Framing Members (Item 7C) are used, gypsum board is installed with long dimensions perpendicular to furring channels. Gypsum board secured to furring channels with nom 1 in. long Type S bugle-head steel screws spaced 8 in. OC in the field of the board. Gypsum board butted end joints shall be staggered minimum 48 in. and centered over main furring channels. At the gypsum board butt joints, each end of each gypsum board shall be supported by a single length of furring channel equal to the width of the gypsum board plus 3 in. on each end. The two supporting furring channels shall be spaced approximately 3 in. in from end joint. Screw spacing along the gypsum board butt joint and along both additional furring channels shall be 8 in. OC. Additional screws shall be placed in the adjacent section of gypsum board into the aforementioned 3 in. extension of the extra butt joint channels as well as into the main channel that runs between. Butt joint furring channels shall be attached with one RESILMOUNT Sound Isolation Clip at each end of the channel.

**AMERICAN GYPSUM CO** — Types AG-C.

**CABOT MANUFACTURING ULC** — Type C

**CERTAINTED GYPSUM INC** — Type C

**CGC INC** — Type C.

**CONTINENTAL BUILDING PRODUCTS OPERATING CO, L L C** — Type LGFC-C/A.

**GEORGIA-PACIFIC GYPSUM L L C** — Types 5, DAPC, TG-C.

**NATIONAL GYPSUM CO** — Types FSK-C, FSW-C.

**PABCO BUILDING PRODUCTS L L C, DBA PABCO GYPSUM** — Type PG-C.

**THAI GYPSUM PRODUCTS PCL** — Type C .

**UNITED STATES GYPSUM CO** — Type C.

**USG BORAL DRYWALL SFZ LLC** — Type C

**USG MEXICO S A DE C V** — Type C.

8A. **Gypsum Board\*** — (Not Shown)- As an alternate to Item 8. Two layers of nom 5/8 in. thick by 48 in. wide boards installed as described in Item 8.

**CGC INC** — Type ULIX

**UNITED STATES GYPSUM CO** — Type ULIX

9. **Screw, Wallboard** — Type S, self-drilling and self-tapping, 1 in. long with bugle head.

10. **Finishing System** — (not shown) — Paper tape embedded in compound over joints and covered with additional compound. Exposed screw heads covered with compound. Edges of compound feathered out.

**\* Indicates such products shall bear the UL or cUL Certification Mark for jurisdictions employing the UL or cUL Certification (such as Canada), respectively.**

