

Design No. **G512**

February 14, 2022

Restrained Assembly Rating — 3 Hr.
Unrestrained Assembly Rating — 3 Hr.
Unrestrained Beam Rating — 3 Hr.

This design was evaluated using a load design method other than the Limit States Design Method (e.g., Working Stress Design Method). For jurisdictions employing the Limit States Design Method, such as Canada, a load restriction factor shall be used — See Guide [BXUV](#) or [BXUV7](#)

* Indicates such products shall bear the UL or cUL Certification Mark for jurisdictions employing the UL or cUL Certification (such as Canada), respectively.

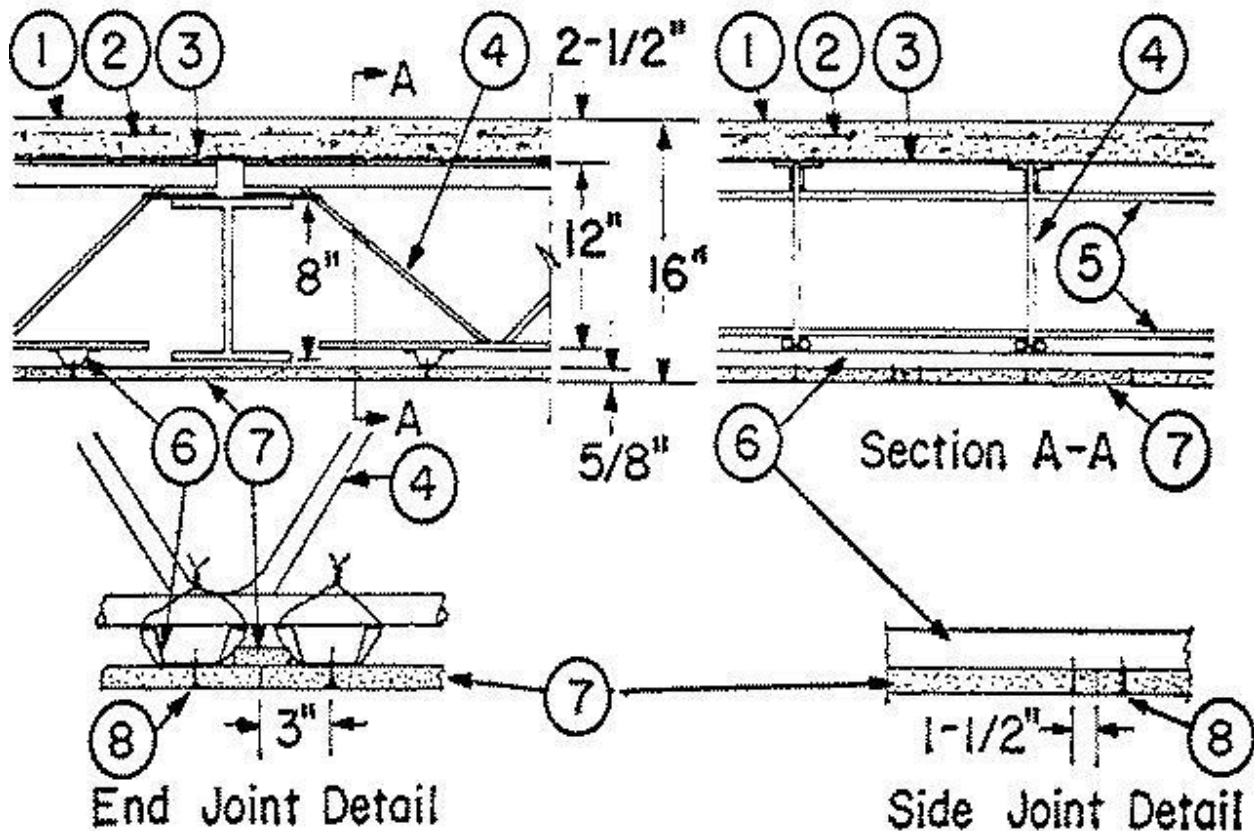

Beam

— W8x35, min size.

1. **Normal-Weight Concrete** — Carbonate or siliceous aggregate, 150 + or - 3 pcf unit weight 4500 psi compressive strength.
2. **Welded Wire Fabric** — 6X6 — W1.4XW1.4.

3. **Metal Lath** — 3/8-in. rib, 3.4 lb/sq yd expanded steel; tied to each joist at every other rib and midway between joists at side lap, with 18 SWG galv steel wire. As an alternate, the form material for the concrete may be corrugated steel deck, 9/16 in. deep, of 28 MSG (min) galv steel, welded to supports 15 in. O.C. with welding washers. The concrete thickness shall be measured to the top plane of the steel deck. Corrugated steel deck to be used with Type 16K4 or larger joists only.

4. **Steel Joists** — Type 12J2 min size; spaced 24 in. O.C. and welded to end supports. Min size of joists for use with corrugated steel deck forms is 16K4 .

5. **Bridging** — 1/2-in. diam continuous steel bar stock; welded to top and bottom chords of each joist.

6. **Furring Channels** — Min 0.020 in. thick (25 gauge) galv steel, 2-9/16 in. or 2-11/16 in. or 2-23/32 in. wide at top and 1-3/4 in. wide at bottom by 7/8 in. deep; spaced 24 in. O.C., perpendicular to joists, except at wallboard end joints as noted below. Two courses of furring channel positioned 6 in. O.C., 3 in. on each side of wallboard end joints. Channels secured to each joist with 18 SWG galv steel wire bent into double strand saddle ties. Channels spliced with adjoining pieces overlapped 6 in. and tied together with strand of 18 SWG galv steel wire at each end of overlap.

6A. **Steel Framing Members*** — (optional, not shown) — alternate method to attach furring channels (Item 6) to joists (Item 4). Clips spaced 48 in. OC., and secured to alternating joists with cup washer installation kit provided by manufacturer. On underside of bottom chord, 1-1/2 in. dia x 3/8 in. deep No. 16 galv steel cup washer is placed to surround the rubber insert. Clip attached to the bottom chord with a 1/4 in. dia. zinc plated bolt inserted through the center grommet and between the chord members; depth of bolt determined as 1-1/2 in. plus the depth of the bottom chord of the joist. Fastened on the top side of the bottom chord with a second cup washer placed open side up, and a 1/4 in. zinc plated "Nyloc" nut. Furring channels are friction fitted into clips. RSIC-1 clip for use with 2-9/16 in. wide furring channels. RSIC-1 (2.75) clip for use with 2-23/32 in. wide furring channels. Ends of adjoining channels are overlapped 6 in. and tied together with double strand of No. 18 SWG galv steel wire near each end of overlap. As an alternate, ends of adjoining channels may be overlapped 6 in. and secured together with two self-tapping No. 6 framing screws, min. 7/16 in. long at the midpoint of the overlap, with one screw on each flange of the channel. Additional clips required to hold furring channel that supports the wallboard butt joints, as described in Item 7.

PAC INTERNATIONAL L L C — Types RSIC-1, RSIC-1 (2.75).

6B. **Steel Framing Members*** — (Optional, Not Shown) - Used as an alternate method to attach furring channels (item 6) to joists (item 4). Clips spaced at 48" OC and secured to the bottom of the joists with cup washer installation kit provided by manufacturer. On underside of bottom chord, 1-1/2 in. dia x 3/8 in. deep No. 16 galv steel cup washer is placed to surround the rubber insert of clip. Clip attached to the bottom chord with a 1/4 in. dia zinc plated bolt inserted through the center grommet and between the chord members; depth of bolt determined as 1-1/2 in. plus the depth of the bottom chord of the joist. Fastened on the top side of the bottom chord with a second cup washer placed open side up, and a 1/4 in. zinc plated "Nyloc" nut. Furring channels are then friction fitted into clips. Ends of channels are overlapped 6" and tied together with double strand of No. 18 AWG galvanized steel wire. Additional clips are required to hold the Gypsum Butt joints as described in Item 6.

STUDCO BUILDING SYSTEMS — RESILMOUNT Sound Isolation Clips - Type A237R

6C. Steel Framing Members* — (optional, not shown) — alternate method to attach 2-23/32 in wide by 7/8 in. deep furring channels (Item 6) to joists (Item 4). Clips spaced 48 in. OC., and secured to alternating joists with cup washer installation kit provided by manufacturer. On underside of bottom chord, 1-1/2 in. dia x 3/8 in. deep No. 16 galv steel cup washer is placed to surround the rubber insert. Clip attached to the bottom chord with a 1/4 in. dia. zinc plated bolt inserted through the center grommet and between the chord members; depth of bolt determined as 1-1/2 in. plus the depth of the bottom chord of the joist. Fastened on the top side of the bottom chord with a second cup washer placed open side up, and a 1/4 in. zinc plated "Nyloc" nut. Furring channels are friction fitted into clips. Ends of adjoining channels are overlapped 6 in. and tied together with double strand of No. 18 SWG galv steel wire near each end of overlap. As an alternate, ends of adjoining channels may be overlapped 6 in. and secured together with two self-tapping No. 6 framing screws, min. 7/16 in. long at the midpoint of the overlap, with one screw on each flange of the channel. Additional clips required to hold furring channel that supports the wallboard butt joints, as described in Item 7.

CLARKDIETRICH BUILDING SYSTEMS — Type ClarkDietrich Sound Clip

7. Gypsum Board* — 5/8 in. thick 4 ft wide; installed with long dimension perpendicular to furring channels and side joints located midway between joists. Wallboard fastened to furring channels with 1 in. wallboard screws spaced 12 in. OC, 1-1/2 in. and 3 in. from butted side and end joints, respectively. End joints attached to double channels and protected on top with 2-3/4 in. wide strips of thick wallboard with joints of strips staggered 8 in. from side joints of the wallboard sheets. End joints of the sheets may be continuous or staggered and similarly fastened to double furring channels that extend 3 in. beyond each end of joint, and which are wire-tied to bottom chord of joists.

When **Steel Framing Members** (Item 6A, 6C) are used, wallboard butt joints shall be staggered min. 2 ft. within the assembly, and occur between the main furring channels. Edge joints may occur beneath the joists. At the wallboard butt joints, each end of the gypsum board shall be supported by a single length of furring channel equal to the width of the wallboard plus 6 in. on each end. The furring channels shall be spaced approximately 3-1/2 in. OC, and be attached to underside of the joist with one RSIC-1 clip at each end of the channel. Gypsum board attached to the furring channels using 1 in. long Type S bugle-head steel screws spaced 8 in. OC along butted end joints and 12 in. OC in the field of the board.

When **Steel Framing Members** (Item 6B) are used, one layer of nom 5/8 in. thick, 4 ft wide gypsum board is installed with long dimensions perpendicular to furring channels. Gypsum board secured to furring channels with nom 1 in. long Type S bugle-head steel screws spaced 8 in. OC in the field of the board. Gypsum board butted end joints shall be staggered minimum 48 in. and centered over main furring channels. At the gypsum board butt joints, each end of each gypsum board shall be supported by a single length of furring channel equal to the width of the gypsum board plus 3 in. on each end. The two supporting furring channels shall be spaced approximately 3 in. in from end joint. Screw spacing along the gypsum board butt joint and along both additional furring channels shall be 8 in. OC. Additional screws shall be placed in the adjacent section of gypsum board into the aforementioned 3 in. extension of the extra butt joint channels as well as into the main channel that runs between. Butt joint furring channels shall be attached with one RESILMOUNT Sound Isolation Clip at each end of the channel.

AMERICAN GYPSUM CO — Type AG-C

CERTAINEED GYPSUM INC — Type C, Type LGFC-C/A.

CGC INC — Type C, IP-X2, IPC-AR.

GEORGIA-PACIFIC GYPSUM L L C — Types 5, DAPC, TG-C

NATIONAL GYPSUM CO — Types FSK-C, FSW-C, FSW-G.

PABCO BUILDING PRODUCTS L L C, DBA PABCO GYPSUM — Type C.

PANEL REY S A — Type PRC.

THAI GYPSUM PRODUCTS PCL — Type C

THE SIAM GYPSUM INDUSTRY (SONGKHLA) CO — Type C

UNITED STATES GYPSUM CO — Type C, IP-X2, IPC-AR

USG BORAL DRYWALL SFZ LLC — Type C

USG MEXICO S A DE C V — Type C, IP-X2, IPC-AR

8. **Screw, Wallboard** — No. 6 Phillips-type, self-drilling and self-tapping, 1 in. long. Screw heads may be either exposed or covered with joint cement.

9. **Finishing System** — (Not Shown) — Wallboard joints may be either exposed or covered with fiber tape and joint compound, except where required for specific edge configuration. For tapered, rounded-edge wallboard, joints covered with fiber tape and joint compound. As an option, nom 3/32

in. thick gypsum veneer plaster may be applied to the entire surface of gypsum board. Joints reinforced.

*** Indicates such products shall bear the UL or cUL Certification Mark for jurisdictions employing the UL or cUL Certification (such as Canada), respectively.**

Last Updated on 2022-02-14