

Design No. G501

October 06, 2020

Restrained Assembly Rating — 1 Hr.

Unrestrained Assembly Rating — 1 Hr.

This design was evaluated using a load design method other than the Limit States Design Method (e.g., Working Stress Design Method). For jurisdictions employing the Limit States Design Method, such as Canada, a load restriction factor shall be used — See Guide [BXUV](#) or [BXUV7](#)

* Indicates such products shall bear the UL or cUL Certification Mark for jurisdictions employing the UL or cUL Certification (such as Canada), respectively.

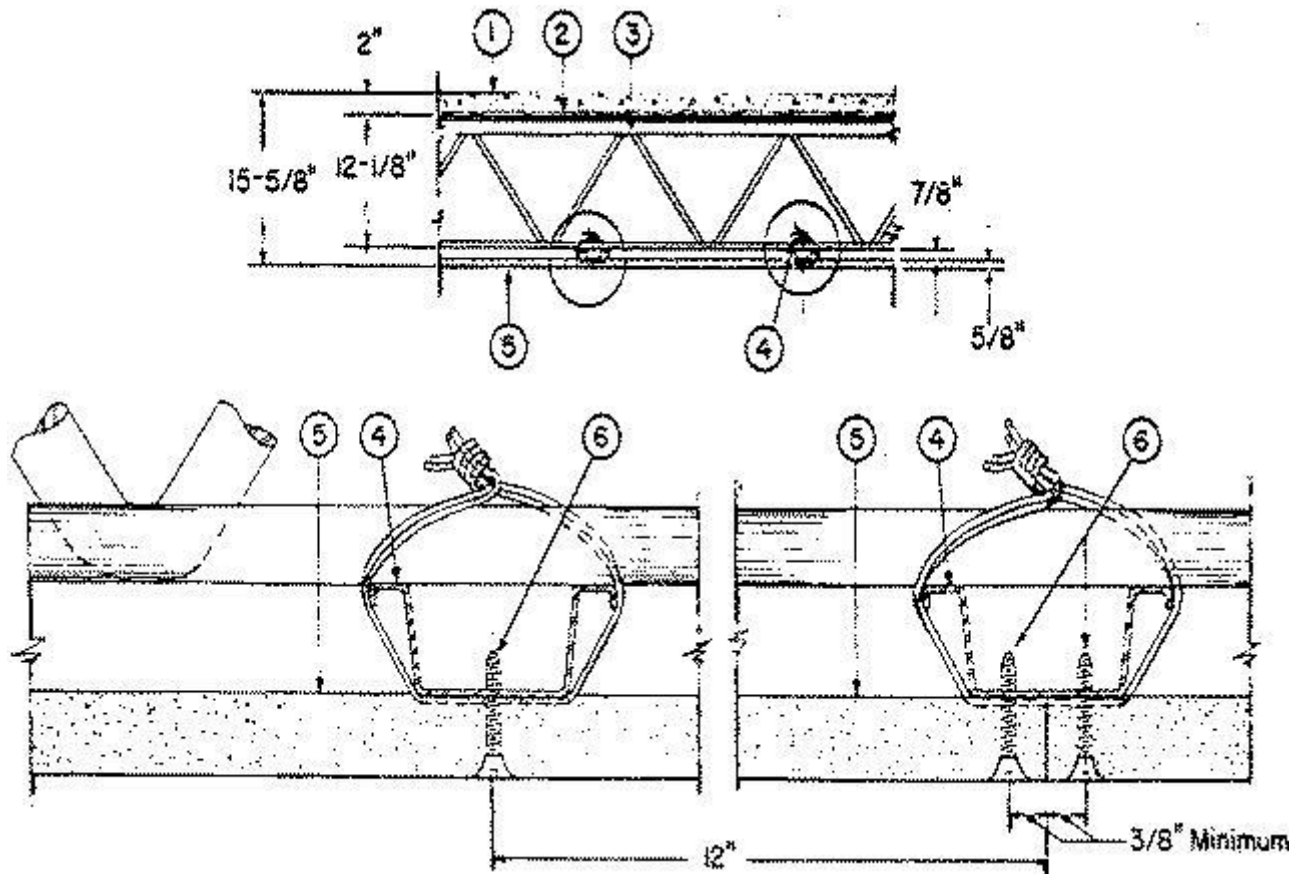

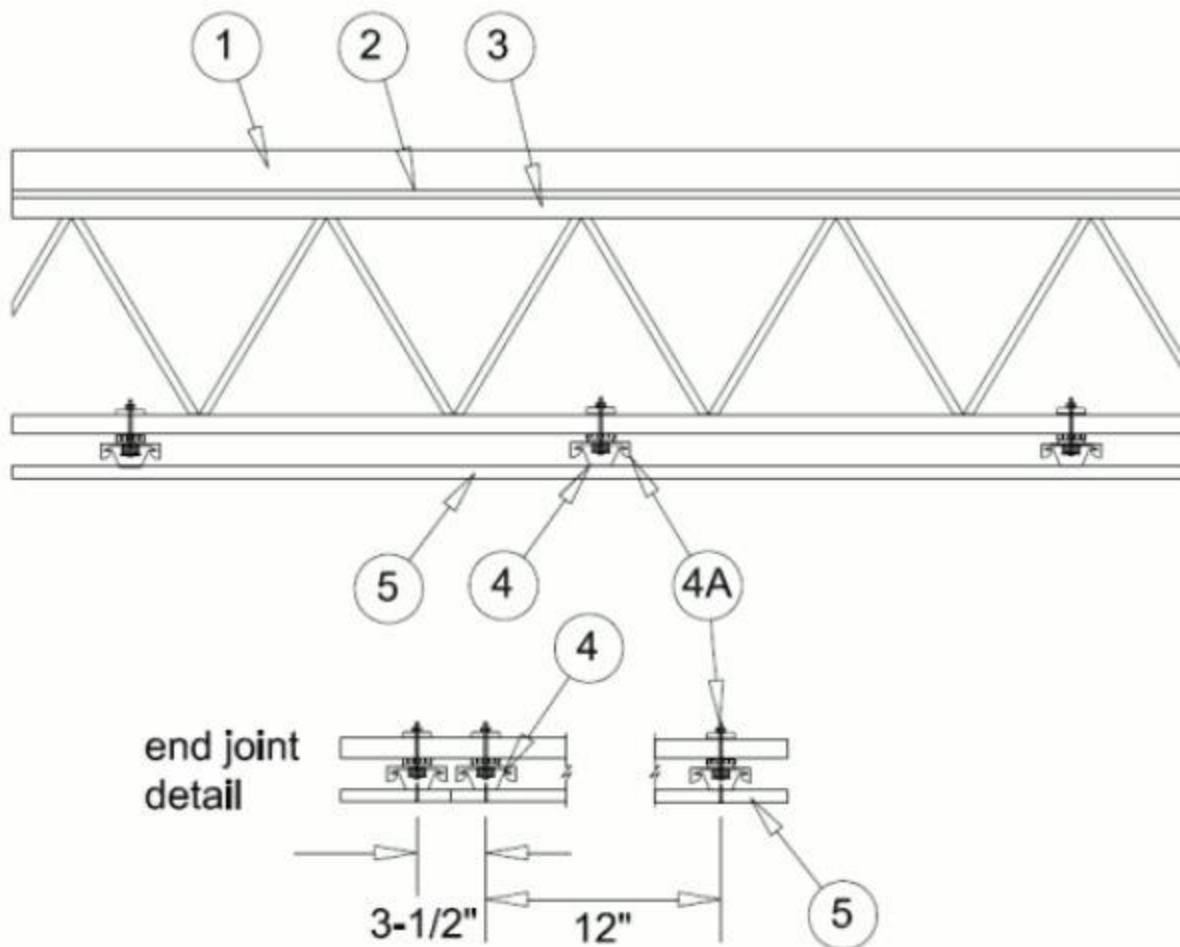

1. **Normal-Weight Concrete** — Carbonate or siliceous aggregate, 150 + or - 3 pcf unit weight, 3000 psi compressive strength.

2. **Metal Lath** — 3/8 in. rib, 3.4 lb/sq yd expanded steel; tied to each joist at every other rib, and midway between joists at side lap with 18 SWG galv steel wire.

As an alternate corrugated steel deck 9/16 in. deep, 28 MSG min galv may be used. Welded to supports 15 in. O.C. using welding washers. The concrete thickness is measured from the surface of the concrete to the top of the steel deck corrugations.

3. **Steel Joists** — Type 12J4 min size; spaced 24 in. O.C. and welded to end supports.

Bridging (Not Illustrated) — Steel bars, 1/2 in. diam. Welded to top and bottom chord of each joist.

4. **Furring Channel** — No. 26 MSG galv steel. 2-3/8 in. or 2-9/16 in. or 2-23/32 in. wide by 7/8 in. deep, spaced perpendicular to joists at 24 in. O.C. except at wallboard end joints as noted below. Channels, secured to joist with a double strand of 18 SWG galv steel wire. Additional pieces of channel 60 in. long located at each wallboard end joint, midway between continuous channels and attached to each joist with double strand 18 SWG galv steel wire. As an alternate, furring channels may be secured to 1-1/2 in. cold-rolled channels at every intersection with double strand 18 SWG galv steel wire. Cold-rolled channels spaced 24 in. O.C. and suspended perpendicular from lower chords of joists with 8 SWG galv steel wire spaced 48 in. O.C. along channels.

4A. **Steel Framing Members*** — (Optional, Not Shown) — Alternate method to attach furring channels (Item 4) to joists (Item 3). Clips spaced 48 in. OC., and secured to alternating joists with cup washer installation kit provided by manufacturer. On underside of bottom chord, 1-1/2 in. dia x 3/8 in. deep No. 16 galv steel cup washer is placed to surround the rubber insert of RSIC-1 and RSIC-1 (2.75) clips. RSIC-1 and RSIC-1 (2.75) clips attached to the bottom chord with a 1/4 in. dia. zinc plated bolt inserted through the center grommet and between the chord members; depth of bolt determined as 1-1/2 in. plus the depth of the bottom chord of the joist. RSIC-V and RSIC-V (2.75) clips attached to the bottom chord with a 1/4 in. dia. zinc plated bolt inserted through the center hole and between the chord members; depth of bolt determined as 9/16 in. plus the depth of the bottom chord of the joist. Fastened on the top

side of the bottom chord with a second cup washer placed open side up, and a 1/4 in. zinc plated "Nyloc" nut. Furring channels are friction fitted into clips. RSIC-1 and RSIC-V clips for use with 2-9/16 in. wide furring channels. RSIC-1 (2.75) and RSIC-V (2.75) clips for use with 2-23/32 in. wide furring channels. Ends of adjoining channels are overlapped 6 in. and tied together with double strand of No. 18 SWG galv steel wire near each end of overlap. As an alternate, ends of adjoining channels may be overlapped 6 in. and secured together with two self-tapping No. 6 framing screws, min. 7/16 in. long at the midpoint of the overlap, with one screw on each flange of the channel. Additional clips required to hold furring channel that supports the wallboard butt joints, as described in Item 5.

PAC INTERNATIONAL L L C — Types RSIC-1, RSIC-V, RSIC-1 (2.75), RSIC-V (2.75)

4B. Steel Framing Members* — (Optional, Not Shown) — Use as an alternate method to attach 2-3/8 in. wide furring channels (Item 4) to joists (Item 3). Clips spaced 48 in. OC., and secured to alternating joists with cup washer installation kit provided by manufacturer. GenieClip clip attached to the bottom chord with a 1/4 in. dia. zinc plated bolt inserted through the center grommet and between the chord members; depth of bolt determined as 1-1/2 in. plus the depth of the bottom chord of the joist. Furring channels are friction fitted into clips. Ends of adjoining channels are overlapped 6 in. and tied together with double strand of No. 18 SWG galv steel wire near each end of overlap. Additional clips required to hold furring channel that supports the wallboard butt joints, as described in Item 5.

PLITEQ INC — Type GenieClip

4C. Steel Framing Members* — (Optional, Not Shown) — Used as an alternate method to attach furring channels (Item 4) to joists (Item 3). Clips spaced at 48" OC and secured to the bottom of the joists with cup washer installation kit provided by manufacturer. Clip attached to the bottom chord with a 1/4 in. dia. zinc plated bolt inserted through the center grommet and between the chord members; depth of bolt determined as 1-1/2 in. plus the depth of the bottom chord of the joist. Furring channels are then friction fitted into clips. Ends of channels are overlapped 6" and tied together with double strand of No. 18 AWG galvanized steel wire. Additional clips are required to hold the Gypsum Butt joints as described in Item 5.

STUDCO BUILDING SYSTEMS — RESILMOUNT Sound Isolation Clips - Type A237 or A237R

4D. Steel Framing Members* — (Optional, Not Shown) — Alternate method to attach 2-23/32 in. wide by 7/8 or 1-1/2 in. deep furring channels (Item 4) to joists (Item 3). Clips spaced 48 in. OC., and secured to alternating joists with cup washer installation kit provided by manufacturer. On underside of bottom chord, 1-1/2 in. dia x 3/8 in. deep No. 16 galv steel cup washer is placed to surround the rubber insert of clips. Clips attached to the bottom chord with a 1/4 in. dia. zinc plated bolt inserted through the center grommet and between the chord members; depth of bolt determined as 1-1/2 in. plus the depth of the bottom chord of the joist. zinc plated "Nyloc" nut. Furring channels are friction fitted into clips. Ends of adjoining channels are overlapped 6 in. and tied together with double strand of No. 18 SWG galv steel wire near each end of overlap. As an alternate, ends of adjoining channels may be overlapped 6 in. and secured together with two self-tapping No. 6 framing screws, min. 7/16 in. long at the midpoint of the overlap, with one screw on each flange of the channel. Additional clips required to hold furring channel that supports the wallboard butt joints, as described in Item 5.

CLARKDIETRICH BUILDING SYSTEMS — Type ClarkDietrich Sound Clip

4E. Steel Framing Members* — (Optional, Not Shown) - Used as an alternate method to attach furring channels to joists. Clips spaced at 48" OC and secured to the bottom of the joists with cup washer installation kit provided by manufacturer. On underside of bottom chord, 1-1/2 in. dia x 3/8 in. deep No. 16 galv steel cup washer is placed to surround the rubber insert of clip. Clip attached to the bottom chord with a 1/4 in. dia zinc plated bolt inserted

through the center grommet and between the chord members; depth of bolt determined as 1-1/2 in. plus the depth of the bottom chord of the joist. Fastened on the top side of the bottom chord with a second cup washer placed open side up, and a 1/4 in. zinc plated "Nyloc" nut. Furring channels are then friction fitted into clips. Ends of channels are overlapped 6" and tied together with double strand of No. 18 AWG galvanized steel wire. Additional clips are required to hold the Gypsum Butt joints as described in Item 5.

REGUPOL AMERICA — Type SonusClip

5. **Gypsum Board*** — 5/8 in. thick, attached with the long dimension at right angles to furring channels and secured to each channel with 1 in. long wallboard screws 12 in. O.C. One screw used to attach adjacent boards to each end of additional furring channel. For wallboard other than 48 in. wide, additional channel to extend min of 6 in. past the end of the end joint. Joint treatment not required for this rating except for tapered, rounded-edge wallboard where edge joints are covered with paper tape and joint compound. As an alternate, nom 3/32 in. thick gypsum veneer plaster may be applied to the entire surface of Classified veneer baseboard. Joints reinforced.

When Steel Framing Members (Item 4A, 4D) are used, wallboard butt joints shall be staggered min. 2 ft. within the assembly, and occur between the main furring channels. Edge joints may occur beneath the joists. At the wallboard butt joints, each end of the gypsum board shall be supported by a single length of furring channel equal to the width of the wallboard plus 6 in. on each end. The furring channels shall be spaced approximately 3-1/2 in. OC, and be attached to underside of the joist with one clip at each end of the channel. Gypsum board attached to the furring channels using 1 in. long Type S bugle-head steel screws spaced 8 in. OC along butted end joints and 12 in. OC in the field of the board. Wallboard joints covered with fiber tape and joint compound.

When Steel Framing Members (Item 4B) are used, one layer of nom 5/8 in. thick, 4 ft wide gypsum board is installed with long dimensions perpendicular to furring channels. Gypsum board secured to furring channels with nom 1 in. long No. 6 Type S bugle-head steel screws spaced 12 in. OC in the field of the board. Gypsum board butted end joints shall be staggered minimum 16 in. within the assembly. At the gypsum board butt joints, each end of each gypsum board shall be supported by a single length of furring channel equal to the width of the gypsum board plus 6 in. on each end. These additional furring channels shall be attached to underside of the joist with Genie clips as described in Item 3E. Screw spacing along the gypsum board butt joint shall be 6 in. OC.

When **Steel Framing Members** (Item 4C) are used, one layer of nom 5/8 in. thick, 4 ft wide gypsum board is installed with long dimensions perpendicular to furring channels. Gypsum board secured to furring channels with nom 1 in. long Type S bugle-head steel screws spaced 8 in. OC in the field of the board. Gypsum board butted end joints shall be staggered minimum 48 in. and centered over main furring channels. At the gypsum board butt joints, each end of each gypsum board shall be supported by a single length of furring channel equal to the width of the gypsum board plus 3 in. on each end. The two supporting furring channels shall be spaced approximately 3 in. in from end joint. Screw spacing along the gypsum board butt joint and along both additional furring channels shall be 8 in. OC. Additional screws shall be placed in the adjacent section of gypsum board into the aforementioned 3 in. extension of the extra butt joint channels as well as into the main channel that runs between. Butt joint furring channels shall be attached with one RESILMOUNT Sound Isolation Clip at each end of the channel.

When Steel Framing Members (Item 4E) are used, gypsum board is installed with long dimensions perpendicular to furring channels. Gypsum board secured to furring channels with nom 1 in. long Type S bugle-head steel screws spaced 8 in. OC in the field of the board. Gypsum board butted end joints shall be staggered minimum 48 in. and centered over main furring channels. At the gypsum board butt joints, an additional single length of furring channel shall be installed and be spaced approximately 3 in. from the butt joint (6 in. from the continuous furring channels) to support the floating end of the gypsum board. Each of these shorter sections of furring channel shall extend one joist beyond the width of the gypsum panel and be attached to the joists with one SonusClip at every joist involved with the butt joint.

AMERICAN GYPSUM CO — Types AGX-1, AG-C, LightRoc

BEIJING NEW BUILDING MATERIALS PUBLIC LTD CO — Type DBX-1

CABOT MANUFACTURING ULC — Type X, 5/8 Type X, Type Blueglass Exterior Sheathing

CERTAINTED GYPSUM INC — Type X, Type X-1 or Type C

CGC INC — Types SCX, ULIX

CONTINENTAL BUILDING PRODUCTS OPERATING CO, L L C — Types LGFC6A, LGFC-C/A

GEORGIA-PACIFIC GYPSUM L L C — Types 5, 9, C, GPFS1, GPFS6, DA, DAP, DAPC, DGG, DS, Type X, Veneer Plaster Base-Type X, Water Rated-Type X, Sheathing Type-X, Soffit-Type X, TG-C, GreenGlass Type X, Type LWX, Veneer Plaster Base-Type LWX, Water Rated-Type LWX, Sheathing Type-LWX, Soffit-Type LWX, Type LW2X, Veneer Plaster Base - Type LW2X, Water Rated - Type LW2X, Sheathing - Type LW2X, Soffit - Type LW2X

NATIONAL GYPSUM CO — Types eXP-C, FSK, FSK-C, FSL, FSMR-C, FSW, FSW-C, FSW-G, FSW-3, FSW-6, FSW-8

PABCO BUILDING PRODUCTS L L C, DBA PABCO GYPSUM — Types C, PG-3, PG-4, PG-6, PG-9, PG-11, PG-C, PGS-WRS or PGI

SIAM GYPSUM INDUSTRY (SARABURI) CO LTD — Type EX-1

THAI GYPSUM PRODUCTS PCL — Type X or Type C

UNITED STATES GYPSUM CO — Types SCX, ULIX

USG BORAL DRYWALL SFZ LLC — Type SCX

5A. Gypsum Board* — As an alternate to items 5 and 6 - 5/8 in. thick, attached with the long dimension at right angles to furring channels and secured to each channel with 2 in. long No. 6 screws spaced 6 in. O.C, starting with a 3 in. stagger. One screw used to attach adjacent boards to each end of additional furring channel. For wallboard other than 48 in. wide, additional channel to extend min of 6 in. past the end of the end joint. Joint treatment not required for this rating except for tapered, rounded-edge wallboard where edge joints are covered with paper tape and joint compound. As an alternate, nom 3/32 in. thick gypsum veneer plaster may be applied to the entire surface of Classified veneer baseboard. Joints reinforced.

CERTAINTED GYPSUM INC — Types EGRG, GlasRoc, GlasRoc-2, Easy-Lite Type X

6. **Wallboard Screw** — No. 6 flathead, self-tapping, sheet metal screws 1 in. long spaced 12 in. O.C. Screws shall be driven no farther than slightly indented (not deeper than 1/64 in.) into the exposed surface of the wallboard.

7. **Batts and Blankets*** — (Not Shown) — For use with Item 4B — Nom 3 in. thick mineral wool insulation held suspended in the concealed space with 0.090 in. diam galv steel wires attached to the steel joists at 18 in. OC.

*** Indicates such products shall bear the UL or cUL Certification Mark for jurisdictions employing the UL or cUL Certification (such as Canada), respectively.**

[Last Updated](#) on 2020-10-06