



### **RSIC-2**

#### **The Resilient Sound Isolation Clip 2 (RSIC-1™ with 3/8" spacer)**



The **RSIC-2** provides a cost effective alternative for wall assemblies where door frames may occur. By using the RSIC-2 the finish wall over all thickness remains an "INDUSTRY STANDARD" thickness. Therefore, NO custom made to order components are required. The RSIC-2 has an overall thickness of 2". When added to a conventional 2" x 4" wall framing the new over all thickness of the framing becomes 5-1/2". The standard thickness of a 2" x 6" stud wall. This allows for the use of standard off the shelf door frames and window casings. Thereby STANDARDIZING the components in the assembly and controlling associated costs related to the wall thickness.

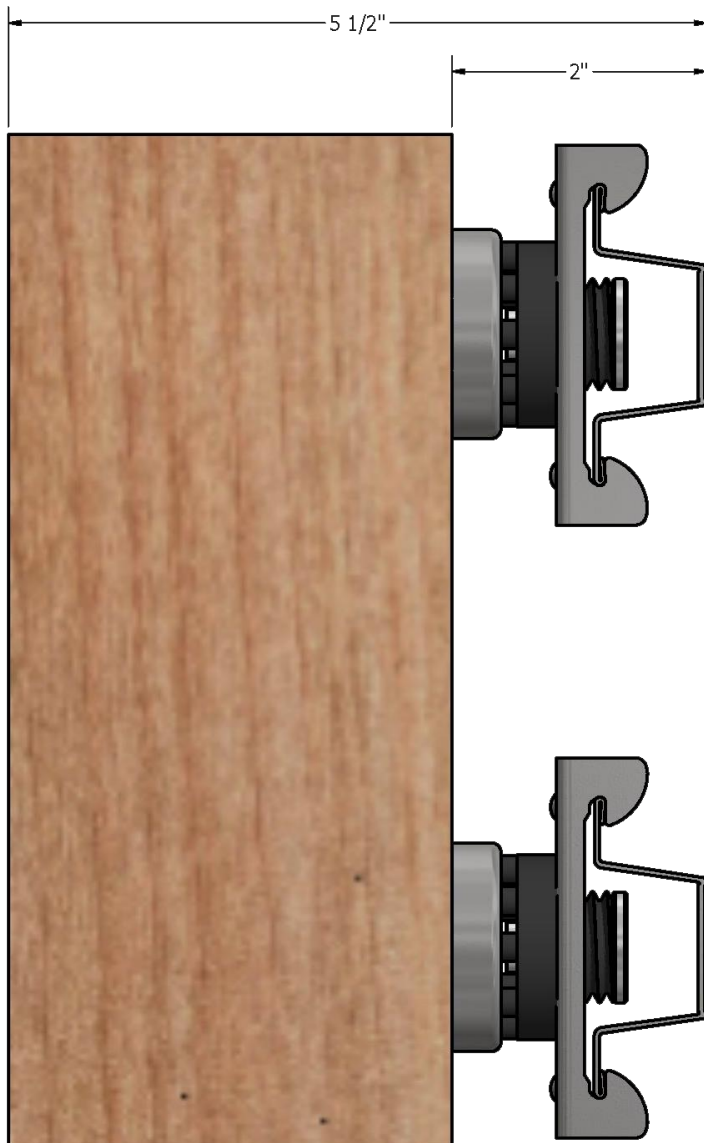

#### **RSIC-2, the Low Cost, High Performance, Noise control Solution**

Apartment
Condo
Commercial
Retail

Recording Studio
Home Theater
Commercial theater
Conference Rooms

#### RSIC-2 specifications:

Acoustical design load:	36 Lbs
Total deflection	3 mm
Double deflection	Yes (1.5 mm)
Low VOC	Yes
Adjustable	NO
Cavity min	4"
Cavity Max	2"
Adjustment limit	2"
Use on Ceilings	Yes
Use on walls	Yes
New Construction	Yes
Assembled In USA	Yes

2

1

B

B

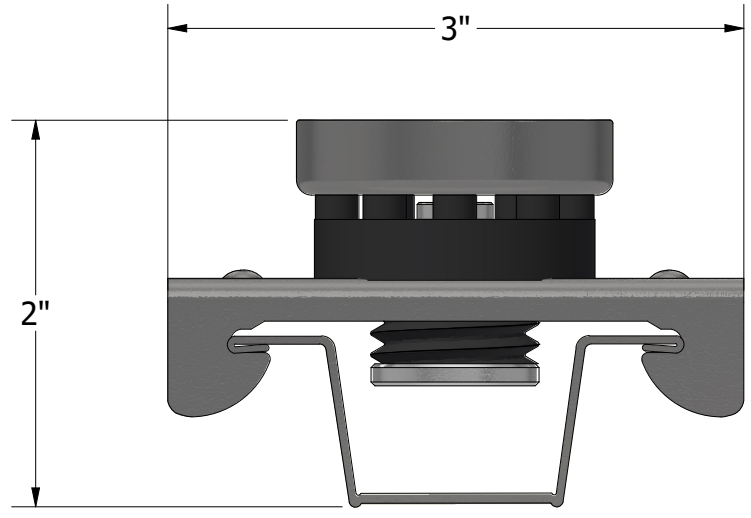

A

A

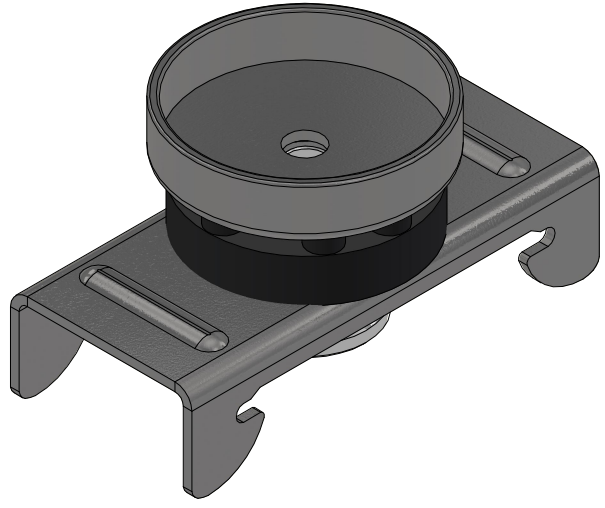

2

1

RSIC-2
1/31/2023
SCALE 1 : 1

**PAC**  
International

World Leader in  
Noise Control  
Solutions



**World Leader in  
Noise Control  
Solutions**



**LEED Analysis  
RSIC-2**

**Recycled Content**

PAC International's RSIC-2 does not contain significant recycled content.

**Fabrication Location**

The RSIC-2 is manufactured in Canby, OR 97013

**Material Source**

The extraction points for the materials in these products cannot be verified. Assume they are outside the 500 mile radius.



**World Leader in  
Noise Control  
Solutions**

## **RSIC ® Safety Data Sheet**

Article Statement

(PAC International, LLC Wall and Ceiling Isolation Products)

This document is provided for clarification of the Safety Data Sheets that you have requested for our product(s). OSHA Hazard Communication Standard requires a SDS for hazardous chemicals; however, the standard exempts all articles from the requirement. The explanation of an article is described per OSHA definition below.

*Pursuant to 29 CFR 1910.1200 (b) (6) (v) and (c), the product described herein is an “article” or is otherwise excluded from OSHA regulations requiring that a Material Safety Data Sheet be prepared for it.*

*An article defined: manufactured item other than a fluid or particle: (i) which is formed to a specific shape or design during manufacturing; (ii) which has an end use function (s) dependent in whole or in part upon its shape or design during end use; and (iii) which does not release, or otherwise result in exposure to, a hazardous chemical under normal conditions of use.*

For technical information and additional resources covering these products please refer to PAC International published literature, e.g., data sheets, product drawings, and installation guidelines at [www.PacInternationalLLC.com](http://www.PacInternationalLLC.com)

As of the date of this document, the foregoing information is believed to be accurate and is provided in good faith to comply with applicable federal and state laws. However, no warranty or representation of law or fact, with respect to such information, is intended or given.



**World Leader in  
Noise Control  
Solutions**

## **RSIC Product Warranty Disclaimer**

### **WARRANTY DISCLAIMER AND LIABILITY LIMITATION LANGUAGE**

**WARRANTY AND DISCLAIMER AND LIABILITY LIMITATION LANGUAGE ONE YEAR WARRANTY** Seller warrants to the original purchaser that its products are free from defects in material or workmanship for one year from the date of purchase from seller. Any allegedly defective product that is portable must be returned to seller prepaid. If upon examination it appears to seller's satisfaction that the product is defective, seller shall repair, replace, or return the purchase price of the product at seller's option. EXCEPT FOR THE FOREGOING, THERE IS NO OTHER WARRANTY, REPRESENTATION OR CONDITION OF ANY KIND; AND ANY OTHER WARRANTY, EXPRESS OR IMPLIED, IS EXCLUDED AND DISCLAIMED. Some states do not allow limitations on implied warranties, so the above limitation may not apply to you.

### **LIABILITY LIMITED TO RETURN OF PURCHASE PRICE**

IT IS AGREED THAT SELLER'S LIABILITY AND PURCHASER'S SOLE REMEDY, WHETHER IN CONTRACT, UNDER ANY WARRANTY, IN TORT (INCLUDING NEGLIGENCE), IN STRICT LIABILITY OR OTHERWISE, SHALL NOT EXCEED THE RETURN OF THE AMOUNT OF THE PURCHASE PRICE PAID BY PURCHASER, AND UNDER NO CIRCUMSTANCES SHALL SELLER BE LIABLE FOR ANY SPECIAL, INCIDENTAL OR CONSEQUENTIAL DAMAGES, INCLUDING, BUT NOT LIMITED TO, PERSONAL INJURY, PROPERTY DAMAGE, DAMAGE TO OR LOSS OF EQUIPMENT, LOST PROFITS OR REVENUE, COSTS OF RENTING REPLACEMENTS AND OTHER ADDITIONAL EXPENSES, EVEN IF SELLER HAS BEEN ADVISED OF THE POSSIBILITY OF SUCH DAMAGES. THE PRICE STATED FOR THE EQUIPMENT IS A CONSIDERATION IN LIMITING SELLER'S LIABILITY AND PURCHASER'S REMEDY. Some states do not allow the exclusion or limitation of incidental or consequential damages, so the above limitation or exclusion may not apply to you.

### **SELLER NOT LIABLE FOR PURCHASER'S NEGLIGENCE**

SELLER WILL NOT BE LIABLE FOR ANY DAMAGES, LOSSES OR EXPENSES AS A RESULT OF PURCHASER'S NEGLIGENCE, WHETHER DEEMED ACTIVE OR PASSIVE AND WHETHER OR NOT ANY SUCH NEGLIGENCE IS THE SOLE CAUSE OF ANY SUCH DAMAGE, LOSS OR EXPENSE.

### **MODEL FOR DEMONSTRATION PURPOSES ONLY**

THE MODEL OR SAMPLE SHOWN BY SELLER TO BUYER IS USED FOR DEMONSTRATION PURPOSES ONLY. THERE IS NO WARRANTY THAT THE GOODS AS DELIVERED SHALL CONFORM TO THE MODEL OR SAMPLE, AND CONFORMITY OF THE GOODS TO THE MODEL OR SAMPLE IS NOT PART OF THE BASIS OF THE BARGAIN BETWEEN SELLER AND BUYER.

### **NO WARRANTY OR COMPLIANCE WITH SAFETY CODE OR REGULATION**

SELLER DOES NOT WARRANT THAT ANY OF THE GOODS SOLD WILL MEET OR COMPLY WITH THE REQUIREMENTS OF ANY SAFETY CODE, BUILDING OR DWELLING CODE, OR REGULATION OF ANY STATE, MUNICIPALITY OR OTHER JURISDICTION.

### **NEVADA LAW APPLIES**

SELLER AND BUYER AGREE THAT ALL ASPECTS OF THIS TRANSACTION INCLUDING THE APPLICABLE STATUTE OF LIMITATIONS SHALL BE GOVERNED BY THE INTERNAL LAW OF THE STATE OF NEVADA, AND NOT THE LAWS OF CONFLICTS.

This warranty gives you specific legal rights, and you may also have other rights which vary from state to state