

RSIC RETRO SOUND ISOLATION SYSTEMS

RSIC-1 RETRO INSTALLATION GUIDE

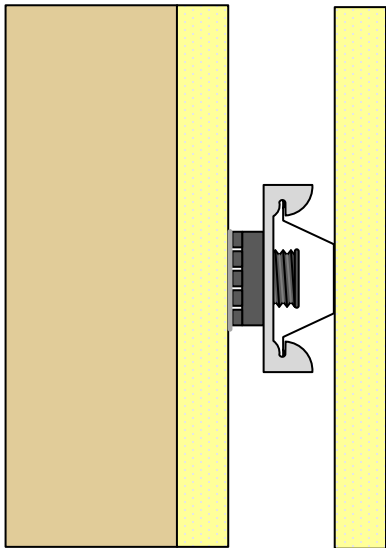
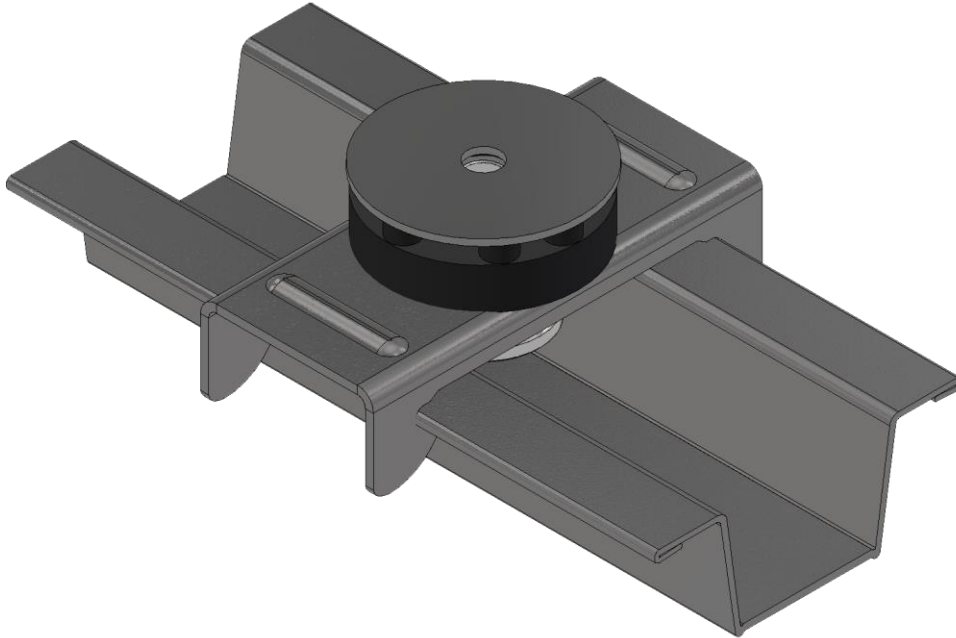

PAC International, Inc. Tel: (866) 774-2100 Fax: (866) 649-2710 Web Site: www.pac-intl.com

© PAC International, LLC. All Rights Reserved. • (866) 774-2100 • Fax (866) 649-2710
RSIC® is a registered Trade Mark of PAC International, LLC.

RSIC RETRO SOUND ISOLATION SYSTEMS

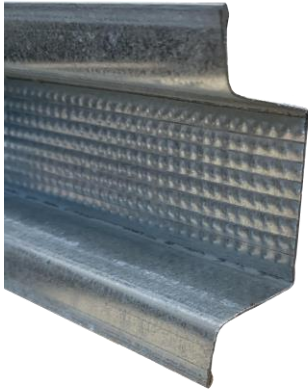

Drywall Furring Channel: (AKA "Hat Track")

- **Requirements:** 25 gauge, hemmed edge detail required on all 25 gauge furring channel. Meets or exceeds SSMA requirements.
- **Depth:** 7/8 inch
- **Width Bottom:** 2-9/16 to 2-11/16 inch wide.
- **Width Top:** 1-1/4 inch wide

Splice drywall furring channel (hat track) with 6 inch overlap in mid span (between two clips) secure with 18 ga tie wire, or two 7/16" framing screws.

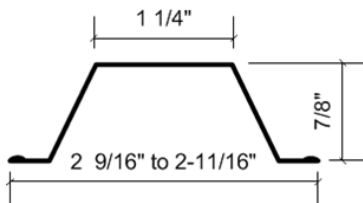

Resilient Sound Isolation Clip (RSIC-1Retro)

- **Maximum Spacing:** 48 inches on center
- **Maximum Acoustical Design Load:** 36 lbs



Coarse thread for wood



Fine thread self driller for steel

Fasteners: RSIC-1 RETRO / RETRO WASHER

- **RSIC-1 to Wood:** #8 min x 3-1/8" to 4" size coarse thread screw. (screw length determined by the thickness of the existing gyp board) Min. penetration into structure to be 1-1/2". IE: a standard wall with one existing layer of gypsum board will require a 3-1/8" or longer screw.
- **RSIC-1 to Steel:** # 8 x 2-1/4" minimum size fine thread screw. (screw length determined by the thickness of the existing gyp board) Min. penetration into framing to be 5/8". IE: a standard wall with one existing layer of gypsum board will require a 2-1/4" or longer screw.
- DO NOT fasten Resilient Sound Isolation Clips (RSIC-1) to framing members with nails. Use only approved screws.

General Information:

- Refer to www.UL.com, or www.pac-intl.com for complete installation details on all fire resistive assembly designs.
- Resilient Sound Isolation Clip, furring channel (hat track) and gypsum board shall not carry heavy loads such as cabinets or bookshelves.
- For focused loads, add RSIC-1 Backer Retro clip.
- Splice furring channel (hat track) with 6 inch overlap in mid span, secure with 18 ga. tie wire or with two framing screws (7/16")
- Seal all potential air leaks with non-hardening acoustical caulking to achieve best noise control results. Use fire rated sealant where required.
- When attaching RSIC clips to Steel framing the minimum allowable gauge of the framing member is 20 ga when spacing is at 24" x 48".
- When attaching to light gauge steel studs (25 ga or 25 ga equivalent) spacing of the RSIC clips is to be max 24" x 24" oc.

PAC International, Inc. Tel: (866) 774-2100 Fax: (866) 649-2710 Web Site: www.pac-intl.com

RSIC RETRO SOUND ISOLATION SYSTEMS

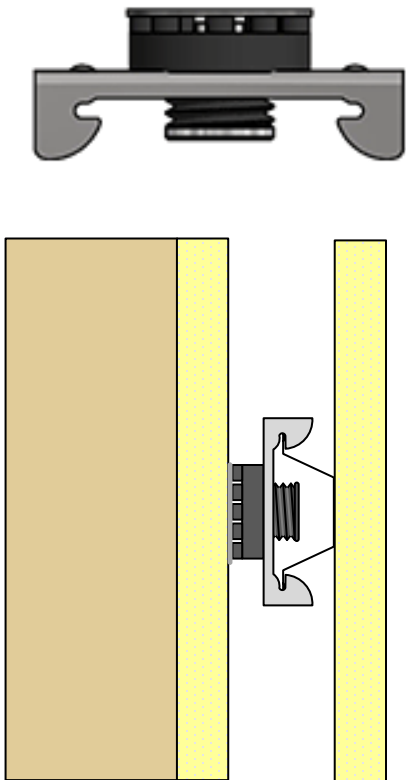

WALLS: One and Two Layers of 5/8" Gypsum Board

- Resilient Sound Isolation Clips shall be 48 inches maximum on center (horizontal).
- Fasten the Resilient Sound Isolation Clip to the substrate with a fastener approved for a ultimate pullout and shear of 120 lbs, or allowable pullout and shear of 36 lbs (See page 2)
- The RSIC-1 RETRO clip requires a RSIC retro washer between the existing finish layer and the RSIC-1 clip. Ensure the RSIC clip is tight to the substrate.
- Locate the first row of RSIC clips within 3 inches from the floor and within 6 inches from the ceiling.
- Snap in the drywall furring channel (hat track) into the RSIC clips (horizontal for walls). (see page 2 for splice details)
- Insulate 1-5/8" cavity with glass fiber insulation
- Place 1/4" (minimum) shim on floor to fully support the gypsum board.
- Install the gypsum board from the bottom up leaving a 1/4" min. gap around the perimeter of the wall and ceiling.
- ONLY remove the shims after ALL the gypsum board is completely screwed to ALL the drywall furring channels. Make sure every screw (floor to ceiling and wall to wall) is installed as required by the assembly design, in every layer of gypsum board before removing the shims at the floor. The shims are critical to ensure best results.
- Caulk around the entire perimeter of the gypsum board. Use fire and smoke rated acoustical sealant where required.

Ceilings: One and Two Layers of 5/8" Gypsum Board

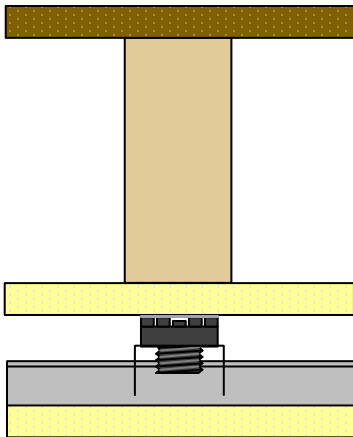

- Resilient Sound Isolation Clips shall be 48 inches maximum on center.
- Fasten the Resilient Sound Isolation Clip to the substrate with a fastener approved for a ultimate pullout and shear of 120 lbs, or allowable pullout and shear of 36 lbs (See page 2)
- The RSIC-1 RETRO clip requires a RSIC retro washer between the existing finish layer and the RSIC-1 clip. Ensure the RSIC clip is tight to the substrate.
- Locate the first row of RSIC clips within 8 inches of the wall at each end of a run.
- Snap in the drywall furring channel (hat track) into the RSIC clips.
- Install 1-5/8" glass fiber insulation in the cavity between the original gypsum board and the new gypsum board
- Install the gypsum board from leaving a 1/4" min. gap around the perimeter of the ceiling.
- Caulk around the entire perimeter of the gypsum board. Use fire and smoke rated acoustical sealant where required.

Residential non-fire rated ceiling systems:

Non fire rated ceiling systems usually found in single family residential homes can be altered to allow additional air flow through the cavity. 1" to 12" round, or square holes can be cut into the original gypsum board ceiling before the RSIC-1 Retro clips are installed to reduce the triple leaf effect on a ceiling system. Several small holes are better than fewer large holes allowing the trapped air to move more freely between the cavities. PAC International recommends a min of one hole per joist cavity, and a total min openings to equal to or greater than 10% of the total ceiling.

PAC International, Inc. Tel: (866) 774-2100 Fax: (866) 649-2710 Web Site: www.pac-intl.com

RSIC RETRO SOUND ISOLATION SYSTEMS

APPLICATION RECOMMENDATION FOR WALLS AND CEILINGS, WOOD OR STEEL FRAMING

INSTALLING RESILIENT SOUND ISOLATION CLIPS (RSIC-1 RETRO CLIP)

RSIC CLIPS AT 24" OC. 1 or 2 Layers of Gyp Board

RSIC-RETRO Wall or Ceiling System Framing at 24" o.c.

RSIC clips at 24" x 48" o.c. 1 or 2 Layers of 5/8" Gypsum Board

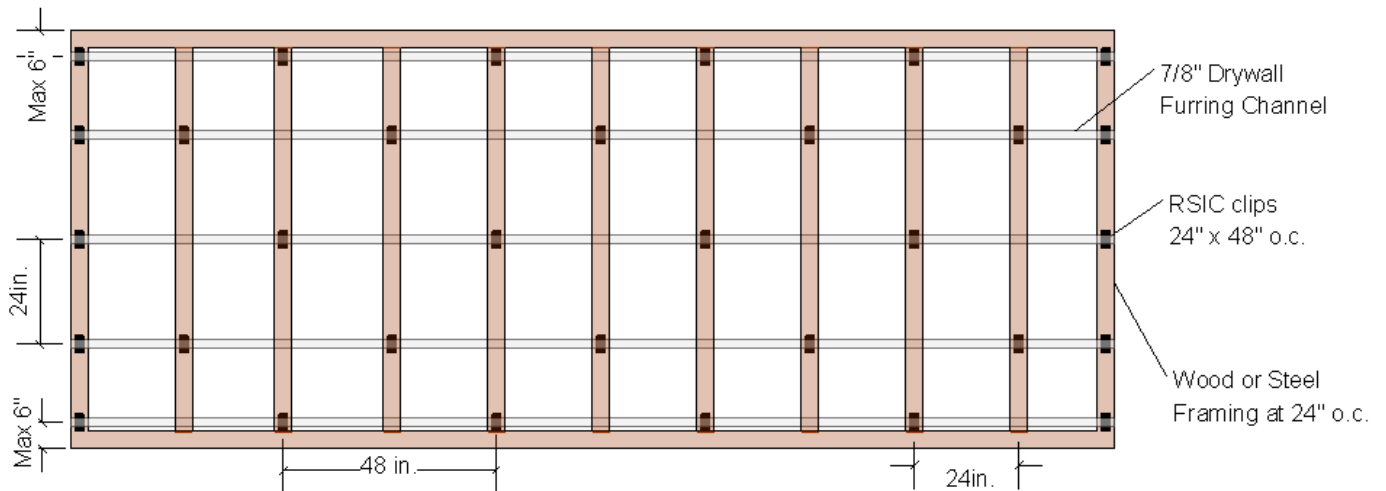

RSIC-RETRO Wall or Ceiling System Framing at 16" o.c.

RSIC clips at 24" x 48" o.c. 1 or 2 Layers of 5/8" Gypsum Board

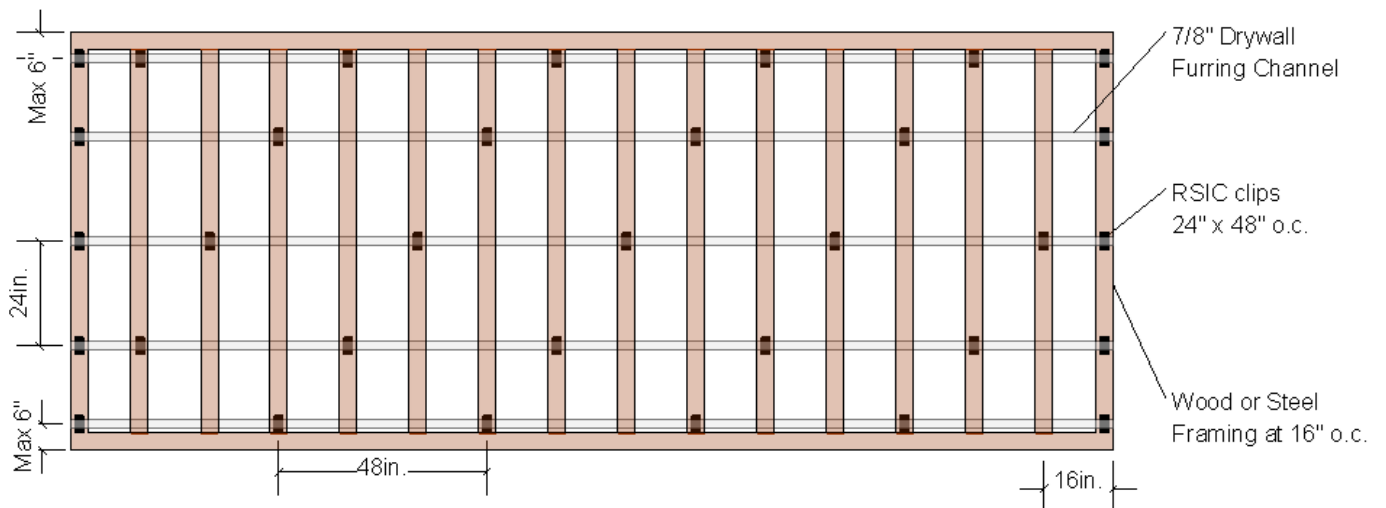

PAC International, Inc. Tel: (866) 774-2100 Fax: (866) 649-2710 Web Site: www.pac-intl.com

RSIC RETRO SOUND ISOLATION SYSTEMS

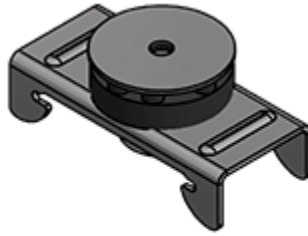

Members of the International Code Council

WARRANTY DISCLAIMER AND LIABILITY LIMITATION LANGUAGE

NO EXPRESS OR IMPLIED WARRANTIES

THERE IS NO WARRANTY, REPRESENTATION OR CONDITION OF ANY KIND; AND ANY WARRANTY, EXPRESS OR IMPLIED, IS EXCLUDED AND DISCLAIMED, INCLUDING THE IMPLIED WARRANTIES OF MERCHANTABILITY AND OF FITNESS FOR A PARTICULAR PURPOSE. Some states do not allow limitations on implied warranties, so the above limitation may not apply to you.

LIABILITY LIMITED TO RETURN OF PURCHASE PRICE

IT IS AGREED THAT SELLER'S LIABILITY AND PURCHASER'S SOLE REMEDY, WHETHER IN CONTRACT, UNDER ANY WARRANTY, IN TORT (INCLUDING NEGLIGENCE), IN STRICT LIABILITY OR OTHERWISE, SHALL NOT EXCEED THE RETURN OF THE AMOUNT OF THE PURCHASE PRICE PAID BY PURCHASER, AND UNDER NO CIRCUMSTANCES SHALL SELLER BE LIABLE FOR ANY SPECIAL, INCIDENTAL OR CONSEQUENTIAL DAMAGES, INCLUDING, BUT NOT LIMITED TO, PERSONAL INJURY, PROPERTY DAMAGE, DAMAGE TO OR LOSS OF EQUIPMENT, LOST PROFITS OR REVENUE, COSTS OF RENTING REPLACEMENTS AND OTHER ADDITIONAL EXPENSES, EVEN IF SELLER HAS BEEN ADVISED OF THE POSSIBILITY OF SUCH DAMAGES. THE PRICE STATED FOR THE EQUIPMENT IS A CONSIDERATION IN LIMITING SELLER'S LIABILITY AND PURCHASER'S REMEDY. Some states do not allow the exclusion or limitation of incidental or consequential damages, so the above limitation or exclusion may not apply to you.

SELLER NOT LIABLE FOR PURCHASER'S NEGLIGENCE

SELLER WILL NOT BE LIABLE FOR ANY DAMAGES, LOSSES OR EXPENSES AS A RESULT OF PURCHASER'S NEGLIGENCE, WHETHER DEEMED ACTIVE OR PASSIVE AND WHETHER OR NOT ANY SUCH NEGLIGENCE IS THE SOLE CAUSE OF ANY SUCH DAMAGE, LOSS OR EXPENSE.

MODEL FOR DEMONSTRATION PURPOSES ONLY

THE MODEL OR SAMPLE SHOWN BY SELLER TO BUYER IS USED FOR DEMONSTRATION PURPOSES ONLY. THERE IS NO WARRANTY THAT THE GOODS AS DELIVERED SHALL CONFORM TO THE MODEL OR SAMPLE, AND CONFORMITY OF THE GOODS TO THE MODEL OR SAMPLE IS NOT PART OF THE BASIS OF THE BARGAIN BETWEEN SELLER AND BUYER.

NO WARRANTY OR COMPLIANCE WITH SAFETY CODE OR REGULATION

SELLER DOES NOT WARRANT THAT ANY OF THE GOODS SOLD WILL MEET OR COMPLY WITH THE REQUIREMENTS OF ANY SAFETY CODE, BUILDING OR DWELLING CODE, OR REGULATION OF ANY STATE, MUNICIPALITY OR OTHER JURISDICTION.

NEVADA LAW APPLIES

SELLER AND BUYER AGREE THAT ALL ASPECTS OF THIS TRANSACTION INCLUDING THE APPLICABLE STATUTE OF LIMITATIONS SHALL BE GOVERNED BY THE INTERNAL LAW OF THE STATE OF NEVADA, AND NOT THE LAWS OF CONFLICTS.

This warranty gives you specific legal rights, and you may also have other rights which vary from state to state.

PAC International, Inc. Tel: (866) 774-2100 Fax: (866) 649-2710 Web Site: www.pac-intl.com

© PAC International, LLC. All Rights Reserved. • (866) 774-2100 • Fax (866) 649-2710

RSIC® is a registered Trade Mark of PAC International, LLC.